

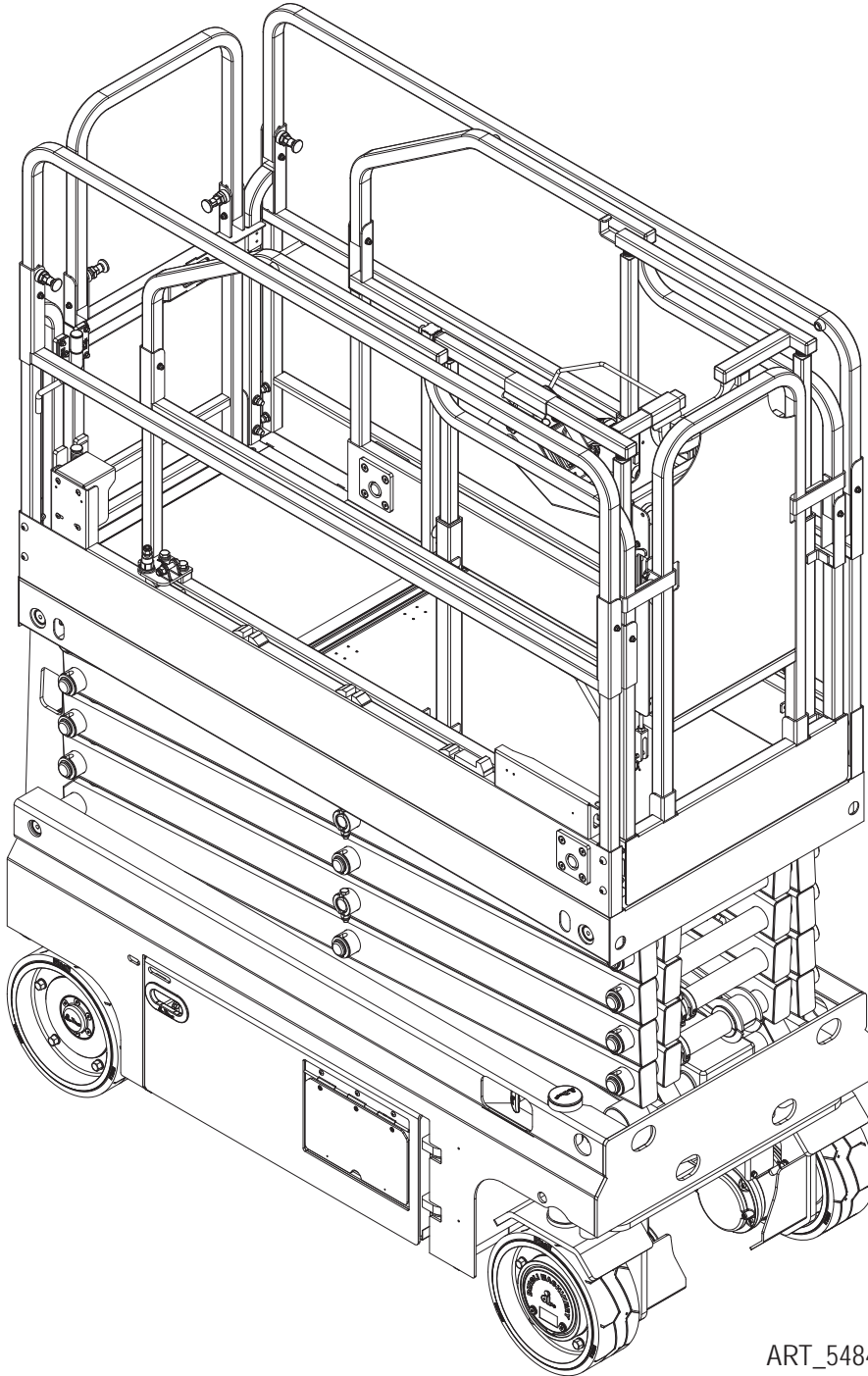

Service & Parts Manual

Micro26-XD



ART_5484

Meets requirements of ANSI A92.20-2020 and CSA B354.6-2019.
Serial Number Range 1990025 - Up

Part # 96899
May 2026

Revision History

Date	Reason for Update
December 2024	New Release
March 2025	Corrected part numbers and descriptions for 44227 and 44237 on page 78. Xtra Deck® registered trademark under U.S. Patent #12,252,380.
August 2025	Removed item #4 information from page 62.
September 2025	Added "13) Lift & Steer Pressure Test" on page 29.
May 2026	Updated artwork and added item #23 for page 54.



MEC Aerial Work Platforms

1401 S. Madera Avenue, Kerman, CA 93630 USA
Toll Free: 1.877.MEC.LIFT or 1.877.632.5438
Phone: 1.559.710.2425
Fax: 1.559.710.2390
info@MECawp.com
www.MECawp.com

Table of Contents

Chapter 1 - Service	1
<i>Service Introduction</i>	1
Section 1 - MEC Operator Policy	2
<i>MEC Operator Policy</i>	2
Section 2 - Safety Symbols & General Safety Tips	3
<i>Safety Symbols & General Safety Tips</i>	3
Section 3 - Torque Specifications	4
<i>Bolt Torque Specification - American Standard</i>	4
<i>Bolt Torque Specification - Metric Standard</i>	5
<i>Hydraulic Components Torque Table</i>	6
Section 4 - Specifications	7
<i>Specifications</i>	7
Section 5 - Maintenance Lock	8
<i>Maintenance Lock</i>	8
Section 6 - Machine Systems	9
<i>Machine Systems</i>	9
Section 7 - Components Locations	10
<i>Component Locations</i>	10
Section 8 - Emergency Systems and Procedures.	11
<i>Emergency Systems and Procedures.</i>	11
Section 9 - Transporting and Lifting Instructions.	12
<i>Transport and Lifting Instructions</i>	12
Section 10 - Calibration Instructions	15
<i>ECU Setting and Calibrations</i>	15
Section 11 - Maintenance	20
<i>Maintenance Inspection Report</i>	20
<i>Daily Maintenance</i>	21
<i>Quarterly Maintenance</i>	24
<i>Semi-annual Maintenance.</i>	32
<i>Annual Maintenance</i>	34
<i>Biennial Maintenance</i>	36
Section 12 - Control Components	38
<i>Control Component Locations.</i>	38
Section 13 - Battery Charger	39
<i>Battery Charger</i>	39

Section 14 - Fault Codes	40
<i>Fault Codes</i>	40
Section 15 - Schematics	47
<i>Hydraulic Schematic</i>	47
<i>Electrical Schematic</i>	48
Chapter 2 - Parts	49
<i>Parts Introduction</i>	49
Section 16 - Chassis.	50
<i>Steer Linkage and Wheels Assembly</i>	50
<i>Pothole Protection Assembly</i>	52
<i>Battery Pack Module</i>	54
<i>Power Unit Module</i>	56
<i>Hydraulic Tank Assembly</i>	58
<i>Ground Control and Cover Assembly</i>	60
<i>Ground Control Assembly</i>	62
<i>Pump Motor Assembly.</i>	64
<i>Rear Wheel and Ladder</i>	66
<i>Charger Assembly</i>	68
<i>Chassis Accessory Installation</i>	70
Section 17 - Scissor	72
<i>Scissor Assembly</i>	72
Section 18 - Platform	76
<i>Main Platform Assembly</i>	76
<i>Xtra Deck® Platform Extension Assembly</i>	78
<i>Xtra Deck® Step Installation</i>	82
<i>Platform Locking Device Assembly</i>	84
<i>Platform Control Assembly</i>	86
<i>Platform Control Box Assembly</i>	88
Section 19 - Hydraulic System	90
<i>Lower Lift Cylinder Assembly</i>	90
<i>Upper Lift Cylinder Assembly</i>	92
<i>Function Manifold</i>	94
<i>Hydraulic Hoses and Fittings</i>	96
Section 20 - Electrical System	98
<i>Electrical Harness</i>	98
<i>Power to Platform</i>	100
Section 21 - Decals	102
<i>Decals</i>	102

Service Introduction

This Service section is designed to provide you, the customer, with the instructions needed to properly maintain the MEC self-propelled aerial work platform. When used in conjunction with the illustrated Parts section in this manual and the Operator's Manual (provided separately), this manual will assist you in making necessary adjustments and repairs, and identifying and ordering the correct replacement parts.

All parts represented here are manufactured and supplied in accordance with MEC quality standards. We recommend that you use genuine MEC parts to ensure proper operation and reliable performance.

To obtain maximum benefits from your MEC Aerial Work Platforms, always follow the proper operating and maintenance procedures. Only trained authorized personnel should be allowed to operate or service this machine. Service personnel should read and study the Operator's, and the Service and Parts Manuals in order to gain a thorough understanding of the unit prior to making any repairs.

MEC Operator Policy

Note: *The best method to protect yourself and others from injury or death is to use common sense. If you are unsure of any operation, **don't start** until you are satisfied that it is safe to proceed and have discussed the situation with your supervisor.*

Service personnel and machine operators must understand and comply with all warnings and instructional decals on the body of the machine, at the ground controls, and platform control console.



MODIFICATIONS OF THIS MACHINE FROM THE ORIGINAL DESIGN AND SPECIFICATIONS WITHOUT WRITTEN PERMISSION FROM MEC ARE STRICTLY FORBIDDEN. A MODIFICATION MAY COMPROMISE THE SAFETY OF THE MACHINE, SUBJECTING OPERATOR(S) TO SERIOUS INJURY OR DEATH.

MEC's policies and procedures demonstrate our commitment to Quality and our relentless ongoing efforts towards Continuous Improvement, due to which product specifications are subject to change without notice.

Any procedures not found within this manual must be evaluated by the individual to assure oneself that they are "proper and safe."

Your MEC Aerial Work Platform has been designed, built, and tested to provide many years of safe, dependable service. Only trained, authorized personnel should be allowed to operate or service the machine.

MEC, as manufacturer, has no direct control over machine application and operation. Proper safety practices are the responsibility of the user and all operating personnel.

If there is a question on application and/or operation, contact MEC Aerial Work Platforms:



MEC Aerial Work Platforms

1401 S. Madera Avenue, Kerman, CA 93630 USA
Toll Free: 1.877.MEC.LIFT or 1.877.632.5438
Phone: 1.559.710.2425
Fax: 1.559.710.2390
info@MECawp.com
www.MECawp.com

Safety Symbols & General Safety Tips

MEC manuals and decals use symbols, colors and signal words to help you recognize important safety, operation and maintenance information.



RED and the word **DANGER** – Indicates an imminently hazardous situation which, if not avoided, will result in death or serious injury.



ORANGE and the word **WARNING** – Indicates a potentially hazardous situation which, if not avoided, could result in death or serious injury.



YELLOW with alert symbol and the word **CAUTION** – Indicates a potentially hazardous situation which, if not avoided, may result in minor or moderate injury.



YELLOW without alert symbol and the word **CAUTION** – Indicates a potentially hazardous situation which, if not avoided, may result in property damage.



GREEN and the word **NOTICE** – Indicates operation or maintenance information.

Regular inspection and constant maintenance is the key to efficient economical operation of your aerial work platform. It will help to assure that your equipment will perform satisfactorily with a minimum of service and repair.



The actual operating environment of the machine governs the inspection schedule. Correct lubrication is an essential part of the preventative maintenance to minimize wear on working parts and ensure against premature failure. By maintaining correct lubrication, the possibility of mechanical failure and resulting downtime is reduced to a minimum.

- Never leave hydraulic components or hoses open. They must be protected from contamination (including rain) at all times.
- Never open a hydraulic system when there are contaminants in the air.
- Always clean the surrounding area before opening hydraulic systems.
- Use only recommended lubricants. Improper lubricants or incompatible lubricants may be as harmful as no lubrication.
- Watch for makeshift “fixes” which can jeopardize safety as well as lead to more costly repair.

Bolt Torque Specification - American Standard

Fasteners

Use the following values to apply torque unless a specific torque value is called out for the part being used.

American Standard Cap Screws								
SAE Grade	5				8			
Cap Screw Size (Inches)								
	Torque				Torque			
	Ft-lbs		Nm		Ft-lbs		Nm	
	Min	Max	Min	Max	Min	Max	Min	Max
1/4 - 20	6.25	7.25	8.5	10	8.25	9.5	11	13
1/4 - 28	8	9	11	12	10.5	12	14	16
5/16 - 18	14	15	19	20	18.5	20	25	27
5/16 - 24	17.5	19	12	26	23	25	31	34
3/8 - 16	26	28	35	38	35	37	47.5	50
3/8 - 24	31	34	42	46	41	45	55.5	61
7/16 - 14	41	45	55.5	61	55	60	74.5	81
7/16 - 20	51	55	69	74.5	68	75	92	102
1/2 - 13	65	72	88	97.5	86	96	116	130
1/2 - 20	76	84	103	114	102	112	138	152
9/16 - 12	95	105	129	142	127	140	172	190
9/16 - 18	111	123	150	167	148	164	200	222
5/8 - 11	126	139	171	188	168	185	228	251
5/8 - 18	152	168	206	228	203	224	275	304
3/4 - 10	238	262	322	255	318	350	431	474
3/4 - 16	274	302	371	409	365	402	495	544
7/8 - 9	350	386	474	523	466	515	631	698
7/8 - 14	407	448	551	607	543	597	736	809
1 - 8	537	592	728	802	716	790	970	1070
1 - 14	670	740	908	1003	894	987	1211	1137





Torque values apply to fasteners as received from the supplier, dry or when lubricated with normal engine oil.

If special graphite grease, molydisulphide grease, or other extreme pressure lubricants are used, these torque values do not apply.

Bolt Torque Specification - Metric Standard

Fasteners

Use the following values to apply torque unless a specific torque value is called out for the part being used.

Metric Cap Screws								
Metric Grade	8.8				10.9			
Cap Screw Size (Millimeters)								
	Torque				Torque			
	Ft-lbs		Nm		Ft-lbs		Nm	
	Min	Max	Min	Max	Min	Max	Min	Max
M6 × 1.00	6	8	8	11	9	11	12	15
M8 × 1.25	16	20	21.5	27	23	27	31	36.5
M10 × 1.50	29	35	39	47	42	52	57	70
M12 × 1.75	52	62	70	84	75	91	102	123
M14 × 2.00	85	103	115	139	120	146	163	198
M16 × 2.50	130	158	176	214	176	216	238	293
M18 × 2.50	172	210	233	284	240	294	325	398
M20 × 2.50	247	301	335	408	343	426	465	577
M22 × 2.50	332	404	450	547	472	576	639	780
M24 × 3.00	423	517	573	700	599	732	812	992
M27 × 3.00	637	779	863	1055	898	1098	1217	1488
M30 × 3.00	872	1066	1181	1444	1224	1496	1658	2027

Torque values apply to fasteners as received from the supplier, dry or when lubricated with normal engine oil.

If special graphite grease, molydisulphide grease, or other extreme pressure lubricants are used, these torque values do not apply.

Hydraulic Components Torque Table

Note: Always lubricate threads with clean hydraulic fluid prior to installation.

Use the following values to torque hydraulic components when a specific value is not available. Always check for torque values in the following places before relying on the Hydraulic Components Torque Table.

- Parts drawings and service instructions in this manual.
- Packaging and instruction sheets provided with new parts.
- Instruction manuals provided by the manufacturer of the component being serviced.

SAE Port Series	Cartridge Poppet		Fittings		Hoses	
	Ft-lbs	Nm	Ft-lbs	Nm	In-lbs	Nm
#4	N/A	N/A	N/A	N/A	135 - 145	15 - 16
#6	N/A	N/A	10 - 20	14 - 27	215 - 245	24 - 28
#8	25 - 30	31 - 41	25 - 30	34 - 41	430 - 470	49 - 53
#10	35 - 40	47 - 54	35 - 40	47 - 54	680 - 750	77 - 85
#12	85 - 90	115 - 122	85 - 90	115 - 122	950 - 1050	107 - 119
#16	130 - 140	176 - 190	130 - 140	176 - 190	1300 - 1368	147 - 155

Specifications

Height, Working Maximum*	Indoor	31.5ft	9.6m
	Outdoor	23ft	7.0m
Height, Platform Maximum	Indoor	24.9ft	7.6m
	Outdoor	16.4ft	5.0m
Height, Stowed Maximum	Rails Up	91.3in	2.32m
	Rails Folded	78.3in	1.99m
Width		31.9in	0.81m
Platform Length	Retracted	74in	1.88m
	Extended	109.5in	2.78m
Maximum Occupants (Indoor)	Xtra Deck® Deployed	1 Person	
	Xtra Deck® Stowed	2 Person	
Maximum Occupants (Outdoor)	Xtra Deck® Deployed	1 Person	
	Xtra Deck® Stowed	1 Person	
Manual Force	Indoor	45lbs	200N
	Outdoor	45lbs	200N
Platform Dimensions (Length x Width)		67.7x29.1in	1.72x0.74m
Extension Deck Length		35.4in	0.9m
Platform Lift Capacity		550lbs	250kg
Maximum Wind Speed		28mph	12.5 m/s (45 km/h)
Wheelbase		55.1in	1.4m
Turning Radius	Outside	66.9in	1.7m
	Inside	0 in	0m
Pothole Ground Clearance	Retracted	3.8in	9cm
	Deployed	0.6in	1.6cm
Weight**		4,453lbs	2,020kg
Controls		Proportional	
Power Source		24V DC	
Tire Size		12.7x4.9in	Φ323x125mm
Gradeability		25% (14°)	
Chassis Inclination		1.5 Side, 3.0 Inline	
Drive Speeds	Platform Lowered	2.8mph	4.5km/h
	Platform Raised	0.4mph	0.6km/h
Maximum Wheel Load		1,496lbs	680kg
Meets or exceeds the requirements of ANSI A92.20-2020 and CSA B354.6.17.			
*Working Height adds 6 feet (2 meters) to platform height.			
**Weight may vary with certain options or configurations.			

Maintenance Lock

DEATH OR SERIOUS INJURY HAZARD!

NEVER perform work or inspection on the machine with the platform elevated without first blocking the scissor assembly with the Maintenance Lock.



DO NOT engage the Maintenance Lock unless the platform is empty of tools and material.

The Maintenance Lock is located at the front of the scissor stack.

1. Raise the platform approximately 10 feet (3 meters) just high enough to rotate the Maintenance Lock into place.
2. Lift the Maintenance Lock, move it to the center of the scissor arm, then rotate it up to a vertical position.

The Maintenance Lock must engage the scissor section above it.



DO NOT set it so that it hangs down.

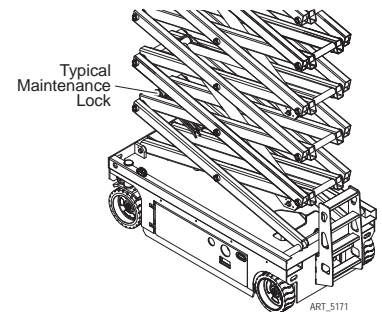

3. Lower the platform until the Maintenance Lock rests securely on the link. Keep clear of the Maintenance Lock when lowering the platform.

Stowing the Maintenance Lock

The Maintenance Lock must be stowed before lowering the platform.



DO NOT attempt to lower the platform with one maintenance lock in place.

1. Raise the platform approximately 1 foot (0.3 meters) higher so that the Maintenance Lock clears the scissor link cross tubes.
2. Slide the front-end Maintenance Lock to the side and rotate it stowed position.
3. Lower the platform.

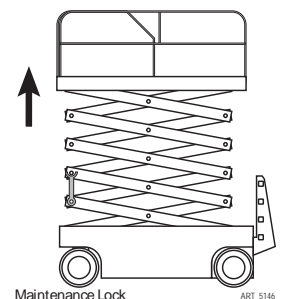

Keep clear of the scissor linkage when lowering.

If a Maintenance Lock requires adjustment to stow it correctly, stop the lowering function. Adjust the maintenance lock while stationary, then return to the lowering function.

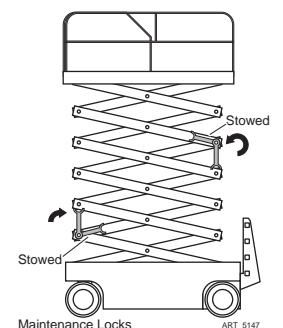

Machine Systems

Hydraulic System



HYDRAULIC FLUID UNDER PRESSURE CAN PENETRATE AND BURN SKIN, DAMAGE EYES, AND MAY CAUSE SERIOUS INJURY, BLINDNESS, AND EVEN DEATH.

CORRECT LEAKS IMMEDIATELY.



Hydraulic fluid leaks under pressure may not always be visible. Check for pin hole leaks with a piece of cardboard, not your hand.

Electrical System



Prevent damage to battery and/or electrical system;

- **Always disconnect the negative battery cable first.**
 - **Always connect the positive battery cable first.**
-

When the negative cable is installed, a spark will occur if contact is made between the positive side of the battery and a metal surface on the machine. This can cause damage to the electrical system, battery explosion, and personal injury.

Total System

FAILURE TO PERFORM PREVENTIVE MAINTENANCE AT RECOMMENDED INTERVALS MAY RESULT IN THE UNIT BEING OPERATED WITH A DEFECT THAT COULD RESULT IN INJURY OR DEATH OF THE OPERATOR.



IMMEDIATELY REPORT TO YOUR SUPERVISOR ANY DEFECT OR MALFUNCTION. ANY DEFECT SHALL BE REPAIRED PRIOR TO CONTINUED USE OF THE AERIAL WORK PLATFORM.

INSPECTION AND MAINTENANCE SHOULD BE PERFORMED BY QUALIFIED PERSONNEL FAMILIAR WITH THE EQUIPMENT.

Component Locations

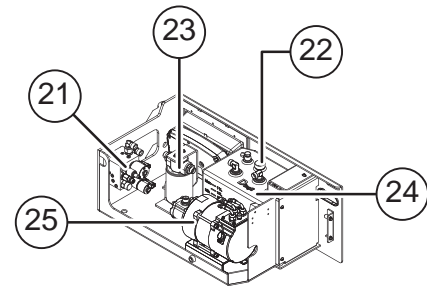
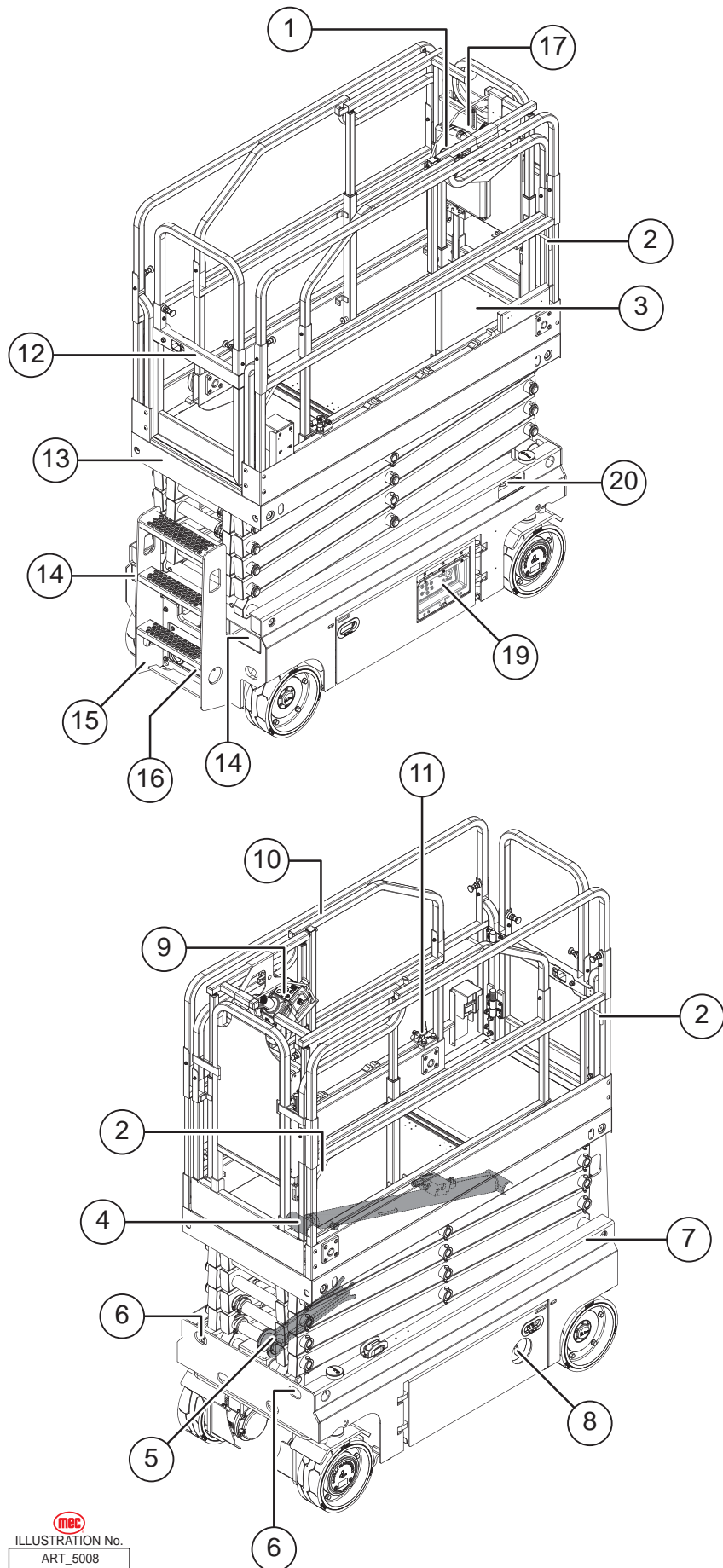

CONTROL MODULE

BATTERY MODULE

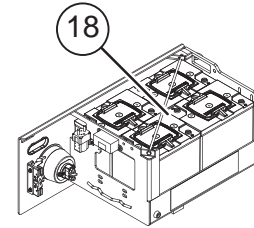

- 1) Manuals Case
- 2) Lanyard Anchorage
- 3) Deck Extension
- 4) Lift Cylinders
- 5) Maintenance Lock
- 6) Tie-Down/Lift Points
- 7) Chassis
- 8) Main Power Switch
- 9) Platform Controls
- 10) Guard Rails
- 11) Deck Extension Release
- 12) Entry Gate
- 13) Main Platform
- 14) Forklift Pockets
- 15) Entry Ladder
- 16) Battery Charger
- 17) Xtra Deck®
- 18) Batteries
- 19) Lower Controls
- 20) Emergency Lowering Handle
- 21) Hydraulic Manifold
- 22) Breather Cap
- 23) Hydraulic Filter
- 24) Hydraulic Reservoir
- 25) Hydraulic Pump & Motor

Emergency Systems and Procedures

IF THE CONTROL SYSTEM FAILS WHILE THE PLATFORM IS ELEVATED, USE THE EMERGENCY LOWERING PROCEDURE TO SAFELY LOWER THE PLATFORM.



DO NOT CLIMB DOWN THE ELEVATING ASSEMBLY OR EXIT THE PLATFORM.

Emergency Stop Switch

The machine is equipped with an Emergency Stop switch at the lower controls and the platform control box.

- Push in the Emergency Stop switch at any time to stop all machine functions.
- Turn switch clockwise or pull the switch out to reset it.
- Pressing either switch will stop all machine functions.
- Both switches must be reset (pulled out) or the machine will not operate.



Emergency Lowering

The Emergency Lowering system is used to lower the platform in case of power failure.

To lower the platform, pull the Emergency Lowering Knob, located near the Base Control panel.

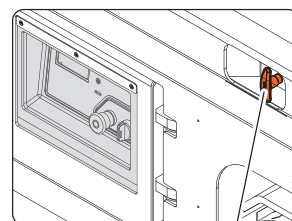

ART_5884 Emergency Lowering Handle

Transport and Lifting Instructions

Safety Information

This section is provided for reference and does not supersede any government or company policy regarding the loading, transport or lifting of MEC machinery.



Truck drivers are responsible for loading and securing machines, and should be properly trained and authorized to operate MEC machinery. Drivers are also responsible for selecting the correct and appropriate trailer according to government regulations and company policy. Drivers must ensure that the vehicle and chains are strong enough to hold the weight of the machine (see the serial number plate for machine weight).

While loading and unloading, the transport vehicle must be parked on a level surface and secured to prevent rolling.

Loading: Free-wheel configuration for Winching or Towing

RUNAWAY HAZARD!



After releasing the brakes there is nothing to stop machine travel. Machine will roll freely on slopes.

ALWAYS chock the wheels before manually releasing the brakes.

Before towing or winching the machine, it is necessary to release the brakes. The machine can be winched or towed short distances at speeds not to exceed 0.5mph (0.8km/h). Reset the brakes after towing or winching.

Brake Release Operation

1. Chock the wheels to prevent the machine from rolling.
2. Pull out the platform and emergency red Emergency Stop button to the On position (pulled out).
3. Turn the key switch to the ground position while pressing and holding down the "Menu Enter Button" button on the ECU panel to enter the password input screen.
4. Press the "Menu Enter Button" 4 times to enter the Menu screen.
5. Press either the "Menu Up Button" or "Menu Down Button" button to switch to the Special mode (" 4. Special Mode ").
6. Press the "Menu Enter Button" button to display the Special mode. Press either the "Menu Up Button" or "Menu Down Button" button to switch to the manual push menu (" 1. Brake Release ").
7. Press "Menu Enter Button" button to display "long press to confirm release of brake". Press and hold down the "Menu Enter Button" button to show "Brake Released!" The horn will sound signaling that all brakes have been released.
8. If you want to reset the brakes, turn the key switch to the ground position.

Driving or Winching onto or off of a Transport Vehicle

Always attach the machine to a winch when loading or unloading from a truck or trailer by driving.



Read and understand all safety, control, and operating information found on the machine and in this manual before operating the machine.

Before loading or unloading the machine, check that:

- The deck extension, controls and component trays are secure.
- The platform is fully lowered.
- All loose items have been removed.

Before driving or winching the machine:

- Attach the machine to a winch.
- Remove all machine tie downs. Remove wheel chocks.

Driving

- Turn the Base Key Switch to Platform. Check that the Emergency Stop Switch is reset by turning it clockwise.
- Enter the platform and reset the Platform Emergency Stop Switch.
- Test platform control functions.
- Select slow drive speed mode. Carefully drive the machine off the transport vehicle with the winch attached.

Note: The brakes are automatically released for driving and will automatically apply when the machine stops.

Winching

- Disengage brakes (see Free-wheel configuration for Winching or Towing on page 12).
- Carefully operate the winch to lower the machine down the ramp.
- Chock the wheels and engage the brakes.



Lifting the machine from the side may result in component damage.

Lifting the machine with a Forklift

- Position the forklift forks in line with the forklift pockets.
- Drive forward to the full extent of the forks.
- Raise the machine 6 inches (15 centimeters) and then tilt the forks back slightly to keep the machine secure.
- Be sure the machine is level when lowering the forks.

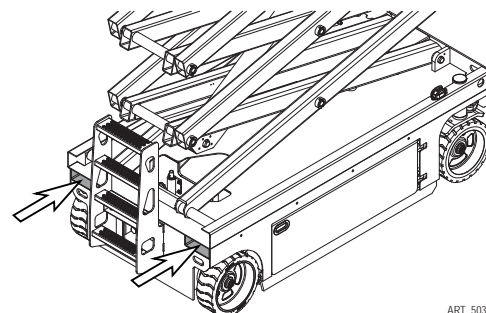

ART_5030

Securing to truck or trailer for Transport

- Turn the Key Switch to off and remove the key before transport.
- Inspect the entire machine for loose or unsecured items.
- Chock the wheels
- Use the tie-down points on the chassis for anchoring down to the transport surface.
- Use chains or straps of ample load capacity.
- Use a minimum of four (4) chains or straps.
- Adjust the rigging to prevent damage to the chains and the machine.

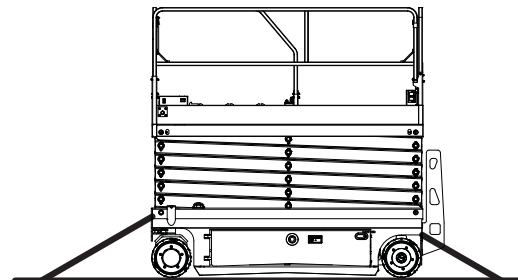
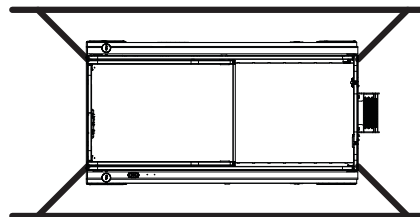

ART_5031

Lifting Instructions

Only qualified riggers should rig and lift the machine.



Ensure that the crane, loading surfaces, spreader bars, cables, chains and straps are of sufficient capacity to withstand the machine weight. See the serial plate for the machine weight.

- Fully lower the platform. Be sure the deck extension is retracted and the controls and component trays are closed and secure. Remove all loose items from the machine.
- Attach rigging to the designated lift points only.
- Adjust the rigging to prevent damage to the machine and to keep the machine level.
- Determine the center of gravity of the machine.

X Axis	Y Axis
25.9 inches (65.8 centimeters)	23 inches (58.4 centimeters)

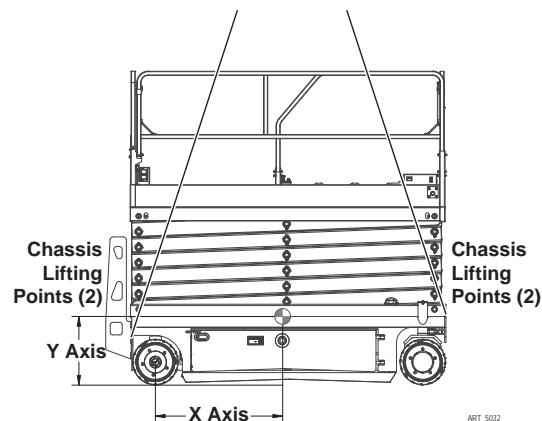

ART_5032

ECU Setting and Calibrations

ECU Setting and Calibrations

To enter the ECU setting interface, pull out the emergency stop buttons on lower and upper controls. Press & hold the “Enter” button on lower controls and turn the key switch to the ground controls. The Password screen will appear



ILLUSTRATION No. ART_6019

Enter password “0000” by repeatedly pressing the Enter button.

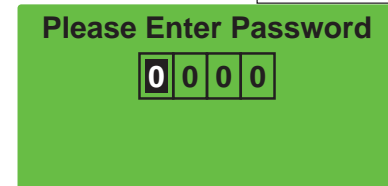

ECU Setting Table

Main Menu	Items	Value
1. Set Speed	1. Max Fast Speed (Drive)	Current value is: 100 (100 to 0807AC, same below) Edit value is: ____
	2. Max Raised Speed (Drive)	Current value is: 13 (13) Edit value is: ____
	3. Max Liftup Speed	Current value is: 75 (50) Edit value is: ____
	4. Max Slow Speed	Current value is: 50 (50) Edit value is: ____
	5. Steer Boost (Driving state)	Current value is: 30 (30) Edit value is: ____
	6. Neutral Steer (Turn-in-place)	Current value is: 30 (30) Edit value is: ____
	7. Deceleration	Current value is: 10 (5) Edit value is: ____
	8. Raised Steer Boost	Current value is: 20 (20) Edit value is: ____
2. Set Option	1. Machine Type	Hydraulic Drive
		Electrical Drive
		Small Electrical Drive Slabs
	2. Pedal Switch	Disable/Enable
	3. Press Sensor Mode	Voltage Output
		Current Output
	4. Pothole Guard	Disable/Enable
5. Descent Delay	Disable/Enable	
6. Motion Alarm	Disable/Enable	
7. Load Sensing	Disable/Enable	

Main Menu	Items	Value
2. Set Option	8. Joystick Direction	Push to Up
		Pull to Up
	9. Enable Indoor/Outdoor Mode	Indoor Mode
		Outdoor Mode
	10. Lowering Cylinder	Dual Cylinder
		Single Cylinder
	11. Test Mode	USE WITH CAUTION!
	12. Drain Alarm Time (After 15 minutes of no operation, an alarm will sound.)	Current value is: 015 Edit value is: ____
	13. Drain Shut Time (After 30 minutes of no operation, the hibernation state is entered.)	Current value is: 030 Edit value is: ____
	14. Battery Low Level	Current value is: 016 Edit value is: ____
	15. Enable Priority	Disable/Enable
16. Enable PCU Collision	Disable/Enable	
17. X Axis Limit	Do Not Change	
18. Y Axis Limit	Do Not Change	
3. Calibration	1. No load Sensing	
	2. Full Load Sensing	
	3. Tilt Sensor	
	4. Angle Sensor	
	5. OL Descent High	
	6. Up Limit	
	7. Down Limit	
	8. Outdoor Limit Height	
4. Special Mode	1. Brake Release	This feature is only available for AC models.
5. Fault History	NO. 1 ErrID: xxx Time: *** Info: ***	
	NO. 2 ErrID: xxx Time: *** Info: ***	
	...	
6. Other	1. Date & Time	
	2. Language	1. English
		2. Chinese
		3. Japanese
		4. French
	3. Revision	ECU: A5 SW-E700-DL-1_M HMI : A5 SW-E700-DL-1_O
	4. Hour Meter Reset	
5. Fault History Reset		
6. PC Link		

Calibration

The below shows what calibration steps that need to be redone after replacing parts!

Calibration	Replaced Part					
	ECU	PCU	ZAPI (Pump)	ZAPI (Drive)	Angle Sensor	Pressure Sensor
Model Selection	X					
Load Sensing	X					X
Tilt Sensor	X					
Angle Sensor Reset	X			X		
Up Limit	X					

Requirements after replacing ECU:

- After the new ECU is installed, you need to select the Model & set the number of cylinders first. (See 2.1. “Machine Type” & 2.10. “Lowering Cylinder” under “Set Options”)
- Then perform Calibrations in the following order:
 - 3. Tilt Sensor
 - 4. Angle Sensor
 - 5. OL Descent High
 - 7. Down Limit
 - 6. Up Limit
 - 1. No load Sensing
 - 2. Full Load Sensing.

This procedure follows ECU replacement; individual calibrations can be performed as needed.

Load Sensing Calibration

No-Load Calibration



After entering the Load Calibration sequence, the platform will automatically raise and lower 3- times for each segment. Make sure that the machine is positioned in an area where it can be elevated to full height before initiating the calibration sequence.

If at any time the automatic elevation must be stopped press the Emergency Stop Switch.

1. With no load on the platform, have the platform stowed and on flat level ground.
2. Enter the “ECU Settings”. (See page 15)
3. Select “3. Calibration”
4. Go to “1. No Load Sensing.” Press and hold the “Enter“ button for 5 seconds. **SEE WARNING!**
5. The machine starts to calibrate automatically. The Overload Indicator light turns on then goes out indicating that the calibration is complete.

Full-Load Calibration



After entering the Load Calibration sequence, the platform will automatically raise and lower 3- times for each segment. Make sure that the machine is positioned in an area where it can be elevated to full height before initiating the calibration sequence.

If at any time the automatic elevation must be stopped, press the Emergency Stop Switch.

Note: Load used for calibration needs to be slightly higher than rated load. The suggested weight for when calibrating a full load is 530 lbs (240 kg).

1. With the machine in the stowed state on a flat level surface, have the maximum rated load on the platform.
2. Enter the "ECU Settings". (See page 15)
3. Select "3. Calibration"
4. Select "2. Full Load Sensing." Press and hold the "Enter" button for 5 seconds. **SEE WARNING ABOVE!**
5. The machine starts to calibrate automatically. The Overload indicator light turns on and then goes out indicating that the calibration is complete.

Tilt Sensing

1. Park the platform on a flat level surface.
2. Enter the "ECU Settings". (See page 15)
3. Select "3. Calibration"
4. Select "3. Tilt Sensor." Press and hold the "Enter" button for 5 seconds.
5. The machine starts to calibrate automatically. The Overload indicator light turns on and then goes out indicating that the calibration is complete.

Angle Sensing

1. Park the machine in the stowed state on a flat level surface
2. Enter the "ECU Settings". (See page 15)
3. Select "3. Calibration"
4. Select "4. Angle Sensor." Press and hold the "Enter" button for 5 seconds.
5. The machine starts to calibrate automatically. The Overload indicator light turns on and then goes out indicating that the calibration is complete

Note: After replacing the angle sensor, only the angle sensor calibration is required, no need to re-calibrate other height values.

Height Calibration

1. Have the machine in the stowed state on a flat surface
2. Enter the "ECU Settings". (See page 15)
3. Select "3. Calibration"
4. Select specific height calibration or perform all. See following instructions.

OL Descent High

Height at which the machine can be lowered when overloaded. Normally, the platform cannot be lowered by controls when overloaded. The emergency lowering cable must be used.

1. Select the "5. OL Descent High."
2. Keep the machine in the stowed state.
3. Press the "Enter" button to save the current value.

Up Limit

After the platform rises to the top, it needs to be lowered slightly to reduce the wear on the lift cylinder.

1. Select the "6. Up Limit."
2. Lift the platform to the highest height.
3. Press the "Enter" button to save the current valve.

Down Limit

When the voltage signal of the "Lift down limit switch" changes from 0V to 24V, the height at this time is the "Decent Delay Height". Therefore, it must be ensured that the "Lift down limit switch" is triggered at the correct height.

1. Select the "7. Down Limit."
2. Keep the machine in the stowed state.
3. Press the "Enter" button to save the current valve.

Outdoor Limit Height

This is set to 10% of max height.

1. Select the "8. Outdoor Limit Height."
2. Lift the platform the maximum outdoor height. then lower 10%.
3. Press the "Enter" button to save the current valve.

Maintenance Inspection Report

SE & MICRO Series Scissors

Fleet Equipment Number _____ Date _____
 Inspector Name _____ Inspector Co. _____
 Model Number _____ Address _____
 Serial Number _____
 Hour Meter _____ Signature _____
 Machine Owner & address _____

Maintain all service records in accordance with ANSI A92.24-2019

* If an inspection receives an "N", remove from service. Once repaired, place an "R" in the box.
 * Refer to the proper service manual for specific information, settings and torque specifications.

Key Y = Yes, Acceptable N = No, Remove from Service R = Repaired 0 = Not Applicable

QUARTERLY - Inspect only those marked "Q" **ANNUAL** - Inspect all items

	Q/A	Y/N/O	R
DECALS:			
Legible - undamaged/readable	Q		
Capacity decal correct for model	Q		
RAILS:			
Not damaged, all in place	Q		
All rail fasteners secure	Q		
Entry gate secure, closes properly	Q		
Manual box in good condition	Q		
Operators Manual in manual box	Q		
PLATFORM EXTENSION:			
Rolls in and out freely	Q		
Lock holds deck in place	Q		
Release pedal moves freely (lube)	Q		
ELEVATING ASSEMBLY:			
Scissor Slide Blocks, lubed	Q		
Maintenance Stand, good Cond	Q		
Beam structures: Straight, no cracks	A		
Welds: secure, no cracks	A		
Retaining Rings	A		
Cylinder Pins, secure	A		
ELECTRICAL:			
GFCI operates correctly	Q		
Wire harnesses good cond, secure	A		
Comm cable no damage, secure	A		
BASE:			
Fasteners tight	Q		
Cover panels secure	Q		
Welds	A		

	Q/A	Y/N/O	R
WHEELS:			
Tire damage	Q		
Lug nuts (Wheel mounting) torqued correctly	Q		
King Pins lubed	A		
COMPONENT AREA:			
Hydraulic - no leaks	Q		
Hydraulic tank, correct level	Q		
Hoses not damaged - Fittings tight	Q		
Valve manifold secure, no leaks	Q		
Power unit secure, no leaks	Q		
Batteries properly filled and cables clean	Q		
Emergency stop, cuts power/operation	Q		
Battery switch cuts battery feed	Q		
Plastic cover secure (door end 2632-4555 only)	A		
Hydraulic tank, oil clean	A		
Replace Hydraulic Filter (if equipped)	A		
Clean or replace tank breather filter	A		
OPERATIONAL INSPECTION:			
All functions, operate smooth and quiet	Q		
All functions, speeds correct.	Q		
Upper control box, operates correctly	Q		
Emergency Down, operates correctly	Q		
Limit switches slows drive when elevated	Q		
Pothole switch test	Q		
Steering pressure relief, set correctly	Q		
Lift pressure relief, set correctly	A		
**Check Platform Overload Sensing operation	A		

**For machine equipped with Platform Overload Protection system only



Daily Maintenance

The following maintenance should be done every daily or 8 hours of operation whichever comes first.

1) Inspect the Manuals and Decals

Maintaining the operator's manual in good condition is essential to safe machine operation. Manuals are included with each machine and should be stored in the container provided in the platform. An illegible or missing manual will not provide safety and operational information necessary for a safe operating condition.

In addition, maintaining all of the safety and instructional decals in good condition is mandatory for safe machine operation. Decals alert operators and personnel to the many possible hazards associated with using this machine. They also provide users with operation and maintenance information. An illegible decal will fail to alert personnel of a procedure or hazard and could result in unsafe operating conditions.

1. Check to make sure that the operator's manual is present and complete in the storage container on the platform.
2. Examine the pages of manual to be sure that they are legible and in good condition.
 - **Result:** The operator's manual is appropriate for the machine and the manual are legible and in good condition.
 - **Result:** The operator's manual is not appropriate for the machine or the manual is not in good condition or is illegible. Remove the machine from service until the manual is replaced.
3. Open the operator's manual to the decals inspection section. Carefully and thoroughly inspect all decals on the machine for legibility and damage.
 - **Result:** The machine is equipped with all required decals, and all decals are legible and in good condition.
 - **Result:** The machine is not equipped with all required decals, or one or more decals are illegible or in poor condition. Remove the machine from service until the decals are replaced.
4. Always return the manual to the storage container after use.

2) Perform Pre-operation Inspection

Completing a Pre-operation Inspection is essential to safe machine operation. The Pre-operation Inspection is a visual inspection performed by the operator prior to each work shift. The inspection is designed to discover if anything is apparently wrong with a machine before the operator performs the function tests. The Pre-operation Inspection also serves to determine if routine maintenance procedures are required.

Complete information to perform this procedure is available in the appropriate operator's manual. Refer to the operator's manual on your machine.

3) Check the Batteries

- New parts maybe be required to perform this procedure.

Proper battery condition is essential to good machine performance and operational safety. Improper fluid levels or damaged cables and connections can result in component damage and hazardous conditions.

Note: This check is not required for machines with lithium batteries, sealed batteries, or Maintenance-free batteries.



Electrocution hazard. Contact with hot or live circuits may result in death or serious injury. Remove all rings, watches and other jewelry.



Bodily injury hazard. Batteries contain acid. Avoid spilling or contacting battery acid. Neutralize battery acid spills with baking soda and water.

1. Put on protective clothing and eye wear.
2. Be sure that the battery cable connections are tight and free of corrosion.
3. Be sure that the battery hold-down bars are secure.
4. Remove the battery vent caps.
5. Check the battery acid level. If needed, replenish with distilled water to the bottom of the battery fill tube. Do not overfill.
6. Install the vent caps.

Note: Adding terminal protectors and a corrosion preventative sealant will help eliminate corrosion on the battery terminals and cables.

4) Check the Hydraulic Oil Level

- New parts maybe be required to perform this procedure.

Maintaining the hydraulic oil at the proper level is essential to machine operation. Improper hydraulic oil levels can damage hydraulic components. Daily checks allow the inspector to identify changes in oil level that might indicate the presence of hydraulic system problems.



Perform this procedure with the platform in the stowed position.

1. Visually inspect the sight of hydraulic oil level from the side of the hydraulic oil tank.
 - **Result:** The hydraulic oil level should be at the 12 scale line mark of the fuel tank. Add oil if necessary. Do not overfill.

Customers shall choose the appropriate hydraulic oil according to the ambient temperature used.

- Original Hydraulic oil specifications: L-HV46

5) Perform Function Tests

Completing the function tests is essential to safe machine operation. Function tests are designed to discover any malfunctions before the machine is put into service. A malfunctioning machine must never be used. If malfunctions are discovered, the machine must be tagged and removed from service.

Complete information to perform this procedure is available in the appropriate operator's manual. Refer to the operator's manual on your machine.

6) Perform 30 Day Service

- Tools maybe be required to perform this procedure.
- New parts maybe be required to perform this procedure.

The 30 day maintenance procedure is a one time procedure to be performed after the first 30 days or 40 hours of usage. After this interval, refer to the maintenance tables for continued scheduled maintenance.

Perform the following Quarterly Maintenance:

- Inspect the Tires, Wheels and Castle Nut Torque (See page 25)

Perform the following Annual Maintenance:

- Replace the Hydraulic Tank Return Filter Element (See page 34)

Quarterly Maintenance

The following maintenance should be done every quarter or 250 hours of operation, whichever comes first.

1) Inspect the Batteries

- Tools maybe be required to perform this procedure.
- New parts maybe be required to perform this procedure.

Proper battery condition is essential to good machine performance and operational safety. Improper fluid levels or damaged cables and connections can result in component damage and hazardous conditions.



Electrocution / burn hazard. Contact with electrically charged circuits could result in death or serious injury. Remove all rings, watches and other jewelry.



Bodily injury hazard. Batteries contain acid. Avoid spilling or contacting battery acid. Neutralize battery acid spills with baking soda and water.

1. Put on protective clothing and eye wear.
2. Release the battery pack latch and rotate the battery pack out and away from the chassis.
3. Be sure that the battery cable connections are free of corrosion.

Note: Adding terminal protectors and a corrosion preventative sealant will help eliminate corrosion on the battery terminals and cables.

4. Be sure that the battery retainers and cable connections are tight.
5. Fully charge the batteries. Allow the batteries to rest 24 hours before performing this procedure to allow the battery cells to equalize.
6. Check each battery pack and verify that the batteries are wired correctly.
7. Inspect the battery charger plug and pigtail for damage or excessive insulation wear. Replace as required.
8. Connect the battery charger to a properly grounded 110 - 230V (50 – 60 Hz) single phase AC power supply.
 - **Result:** The charger should operate and begin charging the batteries.
 - **Result:** If, simultaneously, the charger alarm sounds and the LEDs blink, correct the charger connections at the fuse and battery. The charger will then operate correctly and begin charging the batteries.

The following must be measured and recorded once the battery has been fully charged, after a waiting time of at least 12 hours:

- Total voltage
- Individual voltage of the block battery

If significant changes to previous measurements or differences between the block batteries are identified, then customer service must be contacted for further testing or repairs.

2) Inspect the Electrical Wiring

- Tools maybe be required to perform this procedure.

Maintaining electrical wiring in good condition is essential to safe operation and good machine performance. Failure to find and replace burnt, chafed, corroded or pinched wires could result in unsafe operating conditions and may cause component damage.



Electrocution / burn hazard. Contact with electrically charged circuits could result in death or serious injury. Remove all rings, watches and other jewelry.

1. Inspect the underside of the chassis for damaged or missing ground strap(s).
2. Inspect the following areas for burnt, chafed, corroded and loose wires:
 - Ground control panel
 - Hydraulic power unit module tray
 - Battery pack module tray
 - Platform controls
3. Turn the key switch to platform control. Pull out the platform and ground red Emergency Stop button to the on position.
4. Raise the platform until the distance of the two sets of scissor at least 19.7in (0.5 meters).
5. Lift the safety arm, move it to the center of the scissor arm and rotate up to a vertical position.
6. Lower the platform until the safety arm rests securely on the link. Keep clear of the safety arm when lowering the platform.



Crushing hazard. Keep hands clear of the safety arm when lowering the platform.

7. Inspect the center chassis area and scissor arms for burnt, chafed and pinched cables.
8. Inspect the following areas for burnt, chafed, corroded, pinched and loose wires:
 - Scissor arms
 - ECU to platform controls
 - Power to platform wiring
9. Inspect for a liberal coating of dielectric grease in the following locations:
 - Between the ECU and platform controls
 - All wire harness connectors Level sensor
10. Raise the platform and return the safety arm to the stowed position.
11. Lower the platform to the stowed position and turn the machine off.

3) Inspect the Tires and Wheels (including castle nut torque)

- Tools maybe be required to perform this procedure.
- New parts maybe be required to perform this procedure.

Maintaining the tires and wheels in good condition is essential to safe operation and good performance. Tire and/or wheel failure could result in a machine tip-over. Component damage may also result if problems are not discovered and repaired in a timely fashion.

1. Check the tire surface and sidewalls for cuts, cracks, punctures and unusual wear.
2. Check each wheel for damage, bends and cracks.
3. Check each bolt for proper torque.

Bolt Torque, Dry	92.2 ft-lbs (125 Nm)
Bolt Torque, Lubricated	84.8 ft-lbs (115 Nm)

4) Test the Emergency Stop

A properly functioning Emergency Stop is essential for safe machine operation. An improperly operating red Emergency Stop button will fail to shut off power and stop all machine functions, resulting in a hazardous situation.

As a safety feature, selecting and operating the ground controls will override the platform controls, except the platform red Emergency Stop button.

1. Turn the key switch to ground control. Pull out the platform and ground red Emergency Stop button to the on position.
2. Push in the red Emergency Stop button at the ground controls to the off position.
 - **Result:** No machine functions should operate.
3. Turn the key switch to platform control. Pull out the platform and ground red Emergency Stop button to the on position.
4. Push in the red Emergency Stop button at the platform controls to the off position.
 - **Result:** No machine functions should operate.

Note: The red Emergency Stop button at the ground controls will stop all machine operation, even if the key switch is switched to platform control.

5) Test the Key Switch

Proper key switch action and response is essential to safe machine operation. The machine can be operated from the ground or platform controls and the activation of one or the other is accomplished with the key switch. Failure of the key switch to activate the appropriate control panel could cause a hazardous operating situation.

Perform this procedure from the ground using the platform controls. Do not stand in the platform.

1. Pull out the platform and ground red Emergency Stop button to the on position.
2. Turn the key switch to platform control.
3. Check the platform up/down function from the ground controls.
 - **Result:** The machine functions should not operate.
4. Turn the key switch to ground control.
5. Check the machine functions from the platform controls.
 - **Result:** The machine functions should not operate.
6. Turn the key switch to the off position.
 - **Result:** No function should operate.

6) Test the Automotive-style Horn

The horn is activated at the platform controls and sounds at the ground as a warning to ground personnel. An improperly functioning horn will prevent the operator from alerting ground personnel of

hazards or unsafe conditions.

1. Turn the key switch to platform control. Pull out the platform and ground red Emergency Stop button to the on position.
2. Push down the horn button at the platform controls.
 - **Result:** The horn should sound.

7) Test the Drive Brakes

- Tools maybe be required to perform this procedure.
- New parts maybe be required to perform this procedure.

Proper brake action is essential to safe machine operation. The drive brake function should operate smoothly, free of hesitation, jerking and unusual noise.

Perform this procedure with the machine on a firm level surface that is free of obstructions, with the platform extension deck fully retracted and the platform in the stowed position.

1. Mark a test line on the ground for reference.
2. Turn the key switch to platform control. Pull out the platform and ground red Emergency Stop button to the on position.
3. Lower the platform to the stowed position.
4. Press the drive function select button.
5. Choose a point on the machine; i.e., contact patch of a tire, as a visual reference for use when crossing the test line.
6. Bring the machine to top drive speed before reaching the test line. Release the function enable switch or the joystick when your reference point on the machine crosses the test line.
7. Measure the distance between the test line and your machine reference point.
 - **Result:** The machine stops within the specified braking distance. No action required.
 - **Result:** The machine does not stop within the specified braking distance

Braking Distance, Maximum	
High Range On Paved Surface	24 in±11.8 in 61 cm±30 cm

Note: The brakes must be able to hold the machine on any slope it is able to climb.

8. Replace the brakes and repeat this procedure beginning with step 1.

8) Test the Drive Speed - Stowed Position

- Tools maybe be required to perform this procedure.

Proper drive functions are essential to safe machine operation. The drive function should respond quickly and smoothly to operator control. Drive performance should also be free of hesitation, jerking and unusual noise over the entire proportionally controlled speed range.

Perform this procedure with the machine on a firm, level surface that is free of obstructions.

1. Create start and finish lines by marking two lines on the ground 40 ft (12.2 meters) apart.
2. Turn the key switch to platform control. Pull out the platform and ground red Emergency Stop button to the on position.

3. Lower the platform to the stowed position.
4. Press the drive function select button.
5. Choose a point on the machine; i.e., contact patch of a tire, as a visual reference for use when crossing the start and finish lines.
6. Bring the machine to top drive speed before reaching the start line. Begin timing when your reference point on the machine crosses the start line.
7. Continue at full speed and note the time when your reference point on the machine passes over the finish line. Refer to specifications.

9) Test the Drive Speed - Raised Position

- Tools maybe be required to perform this procedure.

Proper drive functions are essential to safe machine operation. The drive function should respond quickly and smoothly to operator control. Drive performance should also be free of hesitation, jerking and unusual noise over the entire proportionally controlled speed range.

Perform this procedure with the machine on a firm, level surface that is free of obstructions.

1. Create start and finish lines by marking two lines on the ground 40 ft (12.2 meters) apart.
2. Turn the key switch to platform control. Pull out the platform and ground red Emergency Stop button to the on position.
3. Press the lift function select button.
4. Press and hold the function enable switch on the joystick.
5. Raise the platform approximately 78.7in (2 meters) from the ground.
6. Press the drive function select button.
7. Choose a point on the machine; i.e., contact patch of a tire, as a visual reference for use when crossing the start and finish lines.
8. Bring the machine to top drive speed before reaching the start line. Begin timing when your reference point on the machine crosses the start line.
9. Continue at full speed and note the time when your reference point on the machine passes over the finish line. Refer to specifications.

10) Test the Slow Drive Speed

- Tools maybe be required to perform this procedure.

Proper drive functions are essential to safe machine operation. The drive function should respond quickly and smoothly to operator control. Drive performance should also be free of hesitation, jerking and unusual noise over the entire proportionally controlled speed range.

Perform this procedure with the machine on a firm, level surface that is free of obstructions.

1. Create start and finish lines by marking two lines on the ground 40 ft (12.2 meters) apart.
2. Turn the key switch to platform control. Pull out the platform and ground red Emergency Stop button to the on position.
3. Lower the platform to the stowed position.
4. Press the slow speed select button.
5. Choose a point on the machine; i.e., contact patch of a tire, as a visual reference for use when crossing the start and finish lines.

6. Bring the machine to top drive speed before reaching the start line. Begin timing when your reference point on the machine crosses the start line.
7. Continue at full speed and note the time when your reference point on the machine passes over the finish line. The time is less than 25 sec.

11) Perform Hydraulic Oil Analysis

- Tools maybe be required to perform this procedure.
- New parts maybe be required to perform this procedure.
- Dealer service may be required to perform this procedure.

Replacement or testing of the hydraulic oil is essential for good machine performance and service life. Dirty oil may cause the machine to perform poorly and continued use may cause component damage. Extremely dirty conditions may require oil changes to be performed more often.

Before replacing the hydraulic oil, the oil may be tested by an oil distributor for specific levels of contamination to verify that changing the oil is necessary.

If the hydraulic oil is not replaced at the two year inspection, test the oil quarterly. Replace the oil when it fails the test. See page 36 for Test or Replace the Hydraulic Oil.

12) Inspect the Hydraulic Tank Cap Venting System

- Tools maybe be required to perform this procedure.

A free-breathing hydraulic tank cap is essential for good machine performance and service life. A dirty or clogged cap may cause the machine to perform poorly. Extremely dirty conditions may require that the cap be inspected more often.

1. Remove the breather cap from the hydraulic tank.
2. Check for proper venting.
 - **Result:** Air passes through the breather cap.
 - **Result:** If air does not pass through the cap, clean or replace the cap. Proceed to step 3.

Note: When checking for positive tank cap venting, air should pass freely through the cap.

3. Using a mild solvent, carefully wash the cap venting system. Dry using low pressure compressed air. Repeat step 2.
4. Install the breather cap onto the hydraulic tank.

13) Lift & Steer Pressure Test

Prepare For Pressure Test

Clean dirt and debris from the area around the test port plug. Remove Port Plug from manifold and insert Test Fitting (part number 43843) in place and tighten. After completing test and adjustments, remove the Test Fitting and reinstall the Port Plug.

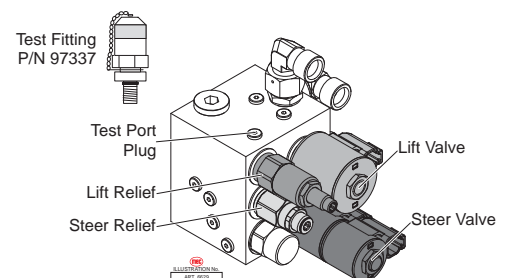

Lift Pressure Test*Hydraulic Relief Valve Settings*

Circuit	PSI	Bar
Lift	2175	150

Operate lift while pulling the Emergency Down Cable simultaneously.
Record highest pressure within 5 seconds. Refer to table for Lift Pressure.

Steer Pressure Test*Hydraulic Relief Valve Settings*

Circuit	PSI	Bar
Steer	1160	80

Pull the Joystick Enable Trigger then press and hold the right steer button until the pressure reaches the highest point (approximately 6 seconds).
Refer to table for Steer Pressure.

Adjust Relief Valve Setting

Refer to the Function Manifold diagram above for relief valve location.
Loosen the Jam Nut and turn the valve inner stem to change the pressure setting.

- Clockwise to increase pressure
- Counterclockwise to decrease pressure

14) Check the Module Tray Latch Components

- Tools maybe be required to perform this procedure.
- New parts maybe be required to perform this procedure.

Maintaining the module tray latch components in good condition is essential to good performance and service life. Failure to detect worn out latch components may result in module trays opening unexpectedly, creating an unsafe operating condition.

1. Inspect each module tray rotary latch and related components for wear. Tighten any loose fasteners.
2. Lubricate each module tray rotary latch. Using light oil, apply a few drops to each of the springs and to the sides of the rotary latch mechanism.

15) Test the Down Limit Switch, the Pothole Limit Switches and the Level Sensor

- Tools maybe be required to perform this procedure.

Maintaining the limit switches is essential to safe operation and good machine performance. Operating the machine with a faulty limit switch could result in reduced machine performance and a potentially unsafe operating condition.

Perform these procedures with the machine on a firm, level surface that is free of obstructions.

Level Sensor

1. Remove the platform controls from the platform.
2. Turn the key switch to platform control. Pull out the platform and ground red Emergency Stop button to the on position.
3. Press the drive function select button
4. Move the machine onto a grade which exceeds the rating of the level sensor. Refer to the serial

- label on the machine.
5. Press the lift function select button. Standing on the up-hill side of the machine, attempt to raise the platform to approximately 94.5in (2.4 meters).
 - **Result:** The LED readout screen shows code LL, an alarm sounds, and the machine stops lifting after the pothole guards are deployed. The machine is functioning properly.
 - **Result:** The LED readout screen does not show code LL, the alarm does not sound and the machine will continue to lift the platform after the pothole guards are deployed. Adjust or replace the level sensor.
 6. Press the drive function select button. Standing on the up-hill side of the machine, attempt to steer and drive the machine.
 - **Result:** The LED readout screen shows code LL, an alarm sounds, and the machine will not steer or drive. The machine is functioning properly.
 - **Result:** The LED readout screen does not show code LL, the alarm does not sound and the steer and drive functions operate. Adjust or replace the level sensor.

Pothole Limit Switches

1. Lower the platform to the stowed position. Move the machine onto a firm, level surface.
2. Place a wooden block approximately 5in (5 centimeters) tall under the right pothole guard.
3. Press the lift function select button. Attempt to raise the platform approximately 94.5in (2.4 meters).
 - **Result:** The pothole guard contacts the block and does not fully deploy, the LED readout screen shows code 18, an alarm sounds and the platform will lift to 94.5in (2.4 meters) or beyond. The machine is functioning properly.
 - **Result:** The pothole guard contacts the block and does not fully deploy, the LED readout screen does not show code 18, the alarm does not sound and the machine will continue to lift the platform after the pothole guards are deployed. Adjust or replace the pothole limit switch.
4. Press the drive function select button. Attempt to steer or drive the machine.
 - **Result:** The LED readout screen shows code 18, an alarm sounds, and the machine will not steer or drive. The machine is functioning properly.
 - **Result:** The LED readout screen does not show code 18, the alarm does not sound and the steer and drive functions operate. Adjust or replace the down limit switch.
5. Lower the platform to the stowed position and remove the block under the right pothole guard.
6. Repeat this procedure beginning with step 34 for the left pothole guard.
7. Lower the platform to the stowed position, remove the block under the left pothole guard.
8. Turn off the machine.

Semi-annual Maintenance

The following maintenance should be done every 6 months or 500 hours of operation, whichever comes first.

1) Test the Platform Overload System

- Tools maybe be required to perform this procedure.
- Dealer service may be required to perform this procedure.

Testing the platform overload system regularly is essential to safe machine operation. Continued use of an improperly operating platform overload system could result in the system not sensing an overloaded platform condition. Machine stability could be compromised resulting in the machine tipping over.

The platform overload system is designed to prevent machine operation in the event the platform is overloaded. Models equipped with the platform overload option are provided with two additional machine control components: the overload pressure sensor and the platform height sensor.

The overload pressure transducer, located at the valve of the lift cylinder, is used to determine the pressure inside the lift cylinder.

The platform height sensor, located at the steer end of the chassis, battery side, is used to determine the height of the platform.

The overload pressure transducer and the platform height sensor provide the GCON with necessary information to determine the load in the platform.

Note: The overload system will not measure loads at or below the height of the Down Limit.

Note: Perform this test from the ground with the platform controller. Do not stand in the platform.



WARNING

Perform this procedure with the machine on a firm, level surface.

1. Turn the key switch to platform controls. Pull out the platform and ground red Emergency Stop button to the on position.
2. Determine the maximum platform capacity.
3. Using a suitable lifting device, place an appropriate test weight equal to the maximum platform capacity in the center of the platform floor. Raise the platform.
 - **Result:** The overload alarm not sounds during the whole trip, indicating a normal condition.
 - **Result:** The overload alarm sounds during the whole trip. Calibrate the platform overload system.
4. The platform should lower to the stowed position
5. Add an additional weight to the platform not to exceed 20% of the maximum rated load. Raise the platform.
 - **Result:** The overload alarm at the platform controls sound, indicating a normal condition.
 - **Result:** The overload alarm at the platform controls does not sound. Calibrate the platform

overload system.

6. Test all machine functions from the platform controls.
 - **Result:** All platform control functions should not operate.
7. Turn the key switch to ground control.
8. Test all machine functions from the ground controls
 - **Result:** All ground control functions should not operate.
9. Lift the test weight off the platform floor using a suitable lifting device.
10. The platform should lower to the stowed position.

2) Replace the Hydraulic Tank Breather Cap

- New parts maybe be required to perform this procedure.

The hydraulic tank is a vented-type tank. The breather cap has an internal air filter that can become clogged or, over time, can deteriorate. If the breather cap is faulty or improperly installed, impurities can enter the hydraulic system which may cause component damage. Extremely dirty conditions may require that the cap be inspected more often.

1. Remove and discard the hydraulic tank breather cap.
2. Install a new cap onto the tank.

Annual Maintenance

The following maintenance should be done every year or 1,000 hours of operation, whichever comes first.

1) Check the Scissor Arm Wear Pads

- Tools maybe be required to perform this procedure.
- New parts maybe be required to perform this procedure.

Maintaining the condition of the scissor arm wear pads is essential to safe machine operation. Continued use of worn out wear pads may result in component damage and unsafe operating conditions.

Perform this procedure with the platform in the stowed position.

1. Measure the distance between the number one arm cross tube and the chassis deck at the ground controls side of the non-steer end of the machine.
 - **Result:** The measurement is 0.9in (23 millimeters) or more. Proceed to step 2.
 - **Result:** The measurement is less than 0.9in (23 millimeters). Replace both wear pads.
2. Measure the distance between the number one arm cross tube and the chassis deck at the battery pack side of the non-steer end of the machine.
 - **Result:** The measurement is 0.9in (23 millimeters) or more. Proceed to step 3.
 - **Result:** The measurement is less than 0.9in (23 millimeters). Replace both wear pads.
3. Apply a thin layer of dry film lubricant to the area of the chassis where the scissor arm wear pads make contact.

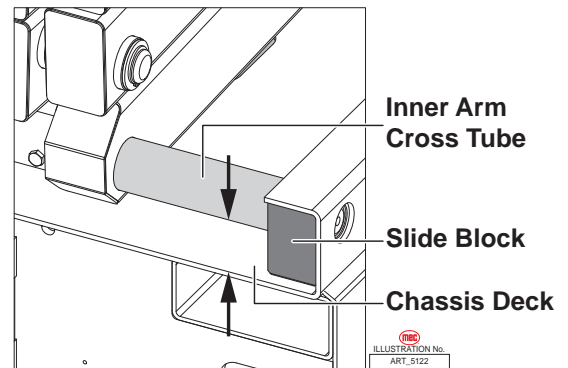

2) Replace the Hydraulic Tank Return Filter Element

- Tools maybe be required to perform this procedure.
- New parts maybe be required to perform this procedure.

Replacement of the hydraulic tank return filter is essential for good machine performance and service life. A dirty or clogged filter may cause the machine to perform poorly and continued use may cause component damage. Extremely dirty conditions may require that the filter be replaced more often.



CAUTION

Beware of hot oil. Contact with hot oil may cause severe burns.



WARNING

The hydraulic tank return filter is mounted on the bracket between the function manifold and the hydraulic power unit.

1. Clean the area around the oil filter. Remove the filter with an oil filter wrench.

2. Apply a thin layer of oil to the new oil filter gasket.
3. Install the new filter and tighten it securely by hand.
4. Use a permanent ink marker to write the date and number of hours from the hour meter onto the filter.
5. Turn the key switch to ground control. Pull out the platform and ground red Emergency Stop button to the on position.
6. Activate and hold the platform up toggle switch.
7. Inspect the filter and related components to be sure that there are no leaks.
8. Clean up any oil that may have spilled.

Biennial Maintenance

The following maintenance should be done every two years or 2,000 hours of operation, whichever comes first.

1) Test or Replace the Hydraulic Oil

- Tools maybe be required to perform this procedure.
- New parts maybe be required to perform this procedure.
- Dealer service may be required to perform this procedure.

Replacement or testing of the hydraulic oil is essential for good machine performance and service life. Dirty oil may cause the machine to perform poorly and continued use may cause component damage. Extremely dirty conditions may require oil changes to be performed more often.

Before replacing the hydraulic oil, the oil may be tested by an oil distributor for specific levels of contamination to verify that changing the oil is necessary.

If the hydraulic oil is not replaced at the two year inspection, test the oil quarterly. Replace the oil when it fails the test.

Note: Perform this procedure with the platform in the stowed position.

1. Disconnect the battery pack from the machine.



Electrocution / burn hazard: Contact with electrically charged circuits could result in death or serious injury. Remove all rings, watches and other jewelry.

2. Open the power unit module tray.
3. Remove the oil drain plug at bottom.
4. Drain all of the oil into a suitable container.
5. Tag and disconnect the hydraulic tank return line from the hydraulic filter head and remove the line from the tank. Cap the fitting on the filter head.
6. Tag and disconnect the hydraulic pump inlet line and remove the line from the tank. Cap the fitting on the pump.
7. Remove the hydraulic tank retaining fasteners and remove the hydraulic tank from the machine.



Bodily injury hazard. Spraying hydraulic oil can penetrate and burn skin. Loosen hydraulic connections very slowly to allow the oil pressure to dissipate gradually. Do not allow oil to squirt or spray.

8. Clean up any oil that may have spilled. Properly discard the used oil.
9. Clean the inside of the hydraulic tank using a mild solvent. Allow the tank to dry completely.

10. Install a new filter onto the tank.
11. Tighten the drain plug and torque to specification.

Torque Specifications	
Hydraulic Tank Drain Plug, Dry	10 in-lbs (4.5 Nm)
Hydraulic Tank Drain Plug, Lubricated	30 in-lbs (3.4 Nm)

12. Install the hydraulic tank and install and tighten the hydraulic tank retaining fasteners. Torque to specification.

Torque Specifications	
Hydraulic Tank Retaining Fasteners, Dry	35 in-lbs (4 Nm)
Hydraulic Tank Drain Plug, Lubricated	26 in-lbs (2.9 Nm)

13. Install the hydraulic pump inlet line into the tank. Install the fitting onto the pump and torque.
14. Install the hydraulic pump return line into the tank. Install the fitting onto the hydraulic filter head and torque.
15. Fill the tank with hydraulic oil until the fluid is full in the hydraulic tank. Do not overfill.
16. Activate the pump to fill the hydraulic system with oil and bleed the system of air.



Component damage hazard. The pump can be damaged if operated without oil. Be careful not to empty the hydraulic tank while in the process of filling the hydraulic system. Do not allow the pump to cavitate.

Control Component Locations

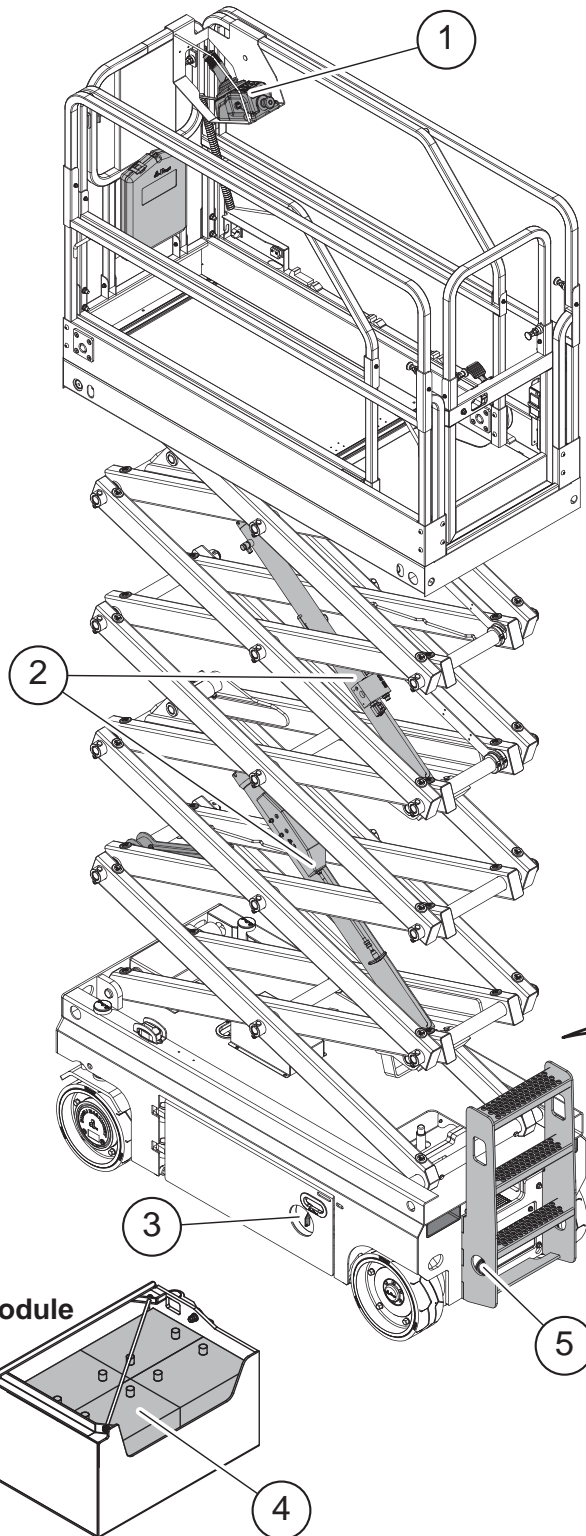

- 1) Platform Controls / PCU
- 2) Lift Cylinders
- 3) Main Power Switch
- 4) Batteries
- 5) Battery Charger
- 6) Lower Controls
- 7) Functions Manifold
- 8) Hydraulic Reservoir
- 9) Hydraulic Pump & Motor
- 10) ECU

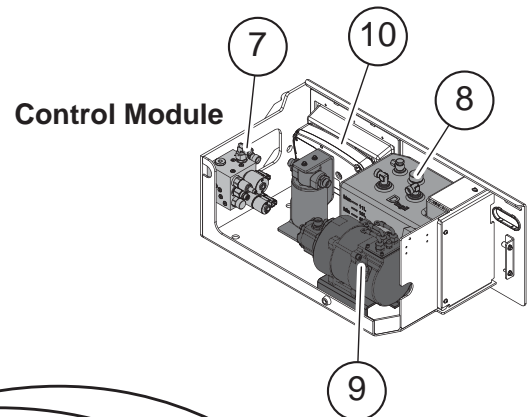

Control Module

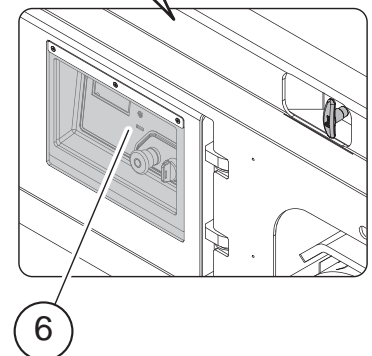

Battery Module

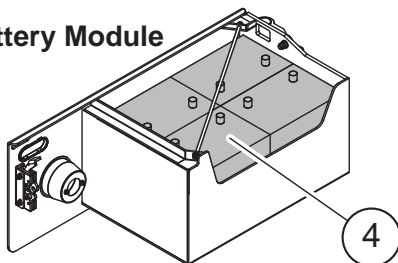
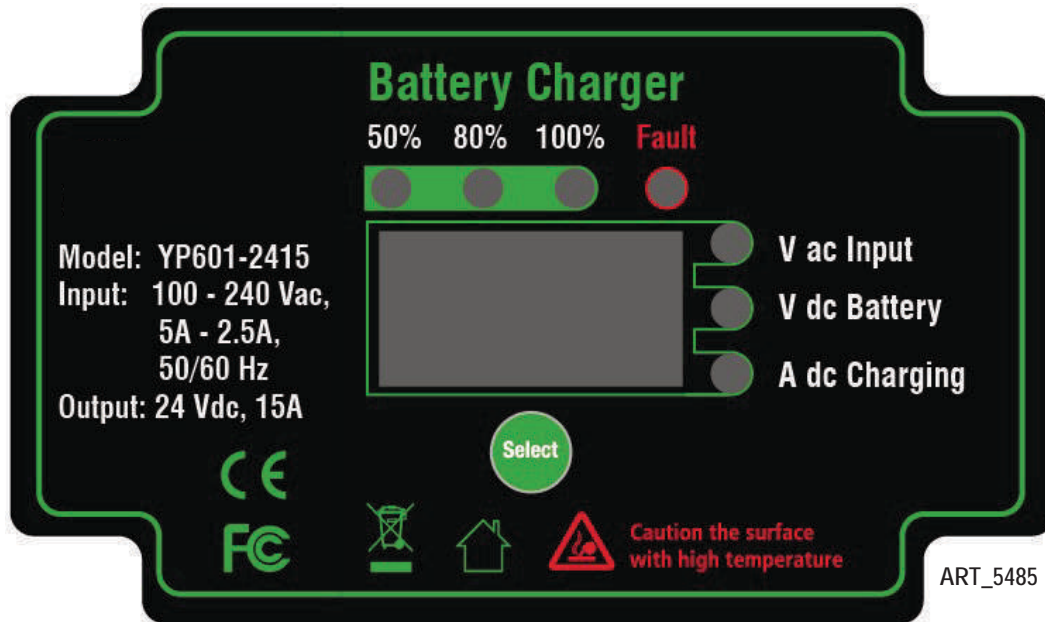



ILLUSTRATION No.
ART_5008

Battery Charger



1. The LED display shows 50%, 80% and 100% of battery capacity. When battery capacity is less than the LED marker, the display will blink. The display lights up when capacity has reached the marker level.
2. Fault LED lights up when irregularities are encountered, for example: high input voltage, no battery connected or over temperature of charger. When this red LED is on, the error code is on display.
3. The LED display can show input AC voltage, battery voltage and charge current the status. LED lights shows the specified status during the charging cycle.
4. When the AC is connected from the main, all LED displays should turn on for 10 seconds and also show the charge curve number. After this, the charger will start to work and the LED display shows AC input voltage, battery voltage and charge current.

Code	Cause Reason	Description
E01	Wrong battery voltage	Output is not connected to battery or battery is incorrectly connected.
E02	Input voltage is out of range.	Please check the input voltage is in 90V-260V.
E03	Battery temperature is too high.	Please lock the connecting terminal with the battery tightly.
E04	The internal temperature of the charger exceeds limit.	Don't put anything over the surface of the charger.
E05	Wrong battery system connected.	The battery voltage not fit the charger.

Fault Codes

The LED readout screen displays fault codes that provide information about the machine operating status and about malfunctions. The fault codes listed in the following charts describe malfunctions and can aid in troubleshooting the machine by pinpointing the area or component affected.



List of Fault Codes			
Code	Description	Lift Reaction	Failure Reason & Solution
01	System Initialization Fault	Disables All Motion	System initialization failure if fault last more than a couple seconds. The system will prohibit all actions. Solution: 1. Try to power on again.
02	System Communication Fault	Disables All Motion	The CAN bus communication between the upper/lower controller is faulty, and the system will prohibit all actions. 1. The lower or upper communication cable is damaged. 2. The upper control is faulty, replace the platform control box. 3. Measure battery voltage. 4. Check power relay. 5. Replace ECU.
03	Invalid Option Setting Fault	Disables All Motion	The current model code inside the ECU is not set to the correct model. Solution: 1. Try to reset the mode code of the corresponding model (for specific operation steps and model codes of each model).
04	Calibration Fault	Warning Only	1. If the angle sensor calibration fails, it may be that the angle sensor analog output changes too little or no change during the calibration process. Check whether the angle sensor is firmly fixed, whether the power supply and wiring are normal. Replace the angle sensor. 2. No-load/full-load calibration fails, it may be that the pressure sensor and angle sensor analog output changes too little or no change during the calibration process, or the machine is not level.
08	Key Switch Error	Disables All Motion	Platform/base control key switch failure or up & down control switching action is too fast. 1. Try to restart the power supply. 2. Replace Key switch.
09	GPS Communication Fault	Warning Only	The built-in GPS module or external GPS module communication failed (if equipped). Solution: 1. Check whether the connection between the CAN communication bus of the external GPS module and the CAN bus of the machine is normal.
10	MC Communication Fault	Warning Only	Check whether the wiring of the motor controller is normal, check the wiring from the controller to the drive motor.
11	BMS Communication Fault (Lithium battery equipped only)	Warning Only	Lithium battery BMS CAN bus communication failure, only alarm. Solution: 1. Check whether the CAN bus communication between the lithium battery and the machine is normal. 2. Replace the lithium battery.

Code	Description	Lift Reaction	Failure Reason & Solution
12	Chassis Up or Down Switch ON	Disable Chassis Control	ECU panel lift buttons failure, ground control operation is prohibited. Solution: 1. Check ECU lift switch.
18	Pothole Guard Fault	Disable Lifting and Driving	If it faults with platform elevated: 1. The left or right pothole is obstructed. 2. Pothole limit switches stuck or needs to be adjusted. If it faults when platform is stowed: 1. Check down limit switch (1930SE to 4555SE). 2. Check angle sensor (Micro13 and 19). Calibrate height.
31	Pressure Sensor 1 Fault	Disables All Motion	1. Check the pressure sensor power supply and its wiring. 2. Check whether the signal input of ECU pressure sensor 1 is normal. (Check ECU No. 45 pin) 3. Possible pressure sensor failure.
32	Angle Sensor Fault	Disables All Motion	1. Check the angle sensor power supply and its wiring. 2. Check whether the ECU angle sensor signal input is normal. (ECU 23 pin) 3. Possible angle sensor problem.
35	Pressure Sensor 2 Fault	Disables All Motion	1. Check the pressure sensor power supply and its wiring to ECU. 2. Check whether the signal input of ECU pressure sensor 2 is normal. (Check ECU 46 pin) 3. Possible pressure sensor failure.
36	Battery Discharged Alarm	Drive speed limit	It indicates that the current battery power is low. In order to prevent the battery from over-discharging, the system will prohibit the lifting function and limit the driving speed. Solution: 1. The battery needs to be charged in time.
37	Battery Drain Shutdown	Disables All Motion	The battery needs to be charged in time.
42	Platform Left Button ON	Warning Only	The operation handle enable, steer right or steer left button is triggered during power on. Solution: 1. Operate the machine 3s after the system is powered on. 2. Replace the joystick handle.
43	Platform Right Button ON	Warning Only	
46	Platform Enable Button ON	Disable Platform Control	
47	Joystick Not In Neutral	Drive speed limit	The joystick is not in the neutral position during power on. 1. Check or replace joystick.
52	Drive Forward Coil Fault	Disable Lifting and Driving	Check ECU Option settings Electric drive models do not have drive coils. 1. Set the correct option code for the machine (for specific operation steps and model codes of each model.
53	Drive Reverse Coil Fault	Disable Lifting and Driving	
54	Lift Up Coil Fault	Disable Lifting and Driving	The platform lifting solenoid valve has open circuit failure, and the lifting and driving functions are prohibited. Solution: 1. Check the solenoid valve coil and its wiring at the valve block.
55	Lift Down Coil Fault	Disable Lifting and Driving	Lift solenoid valve open circuit failure when the platform is lowered. Solution: 1. Check the lowering solenoid valve coil and its wiring at the lift cylinder valve block.
56	Steer Right Coil Fault	Disable Lifting and Driving	Right/left steer solenoid valve open circuit failure. Solution: 1. Check the right turn/left turn solenoid valve coil and its wiring at the valve block.
57	Steer Left Coil Fault	Disable Lifting and Driving	
59	Parallel Coil Fault	Disable Lifting and Driving	1. Check ECU options settings. Electric drive models are not equipped with parallel coils.

Code	Description	Lift Reaction	Failure Reason & Solution
68	Battery Low Voltage	Disables All Motion	It is reminded that the battery power is lower than the preset value, and the machine needs to be charged in time to protect the battery from over- discharge and damage.
80	Platform Load is over 80%	Warning Only	Prompt that the load of the current exceeds 80% / 90% / 99% of the rated load, only an alarm does not limit the action.
90	Platform Load is over 90%	Warning Only	
99	Platform Load is over 99%	Warning Only	
PCU: LL ECU: 100	Machine out of level	Disable Lifting and Driving	Indicates that the machine is in a tilted state in excess of maximum tilt angle value. Lifting and driving operations are prohibited. You need to descend to the lower limit and drive to a solid level surface to work at heights.
PCU: OL ECU: 101	Platform Overloaded	Prohibition of lifting and driving; The platform is forbidden to descend after exceeding the "overload descent height"	It prompts that the current platform load exceeds the rated load. In order to ensure the safe use of the equipment, the system will prohibit the lifting and driving functions at this time, and it is forbidden to descend above the overloaded descending height.
102	Restore Parameters to Default	Warning Only	/
103	Battery is draining	Warning Only	/
104	Motor Controller Fault	Warning Only	Press Yellow Down arrow for the 4-digit fault code. See Motor Controller fault codes listed later in this section.
105	BMS Alarm	Prohibit lifting, limit driving speed	The lithium battery management system has an alarm, and the control system will prohibit the lifting function and limit the driving speed at this time. Disregard if not Lithium
106	BMS Fault	Disable All Motion	Lithium battery management system fails, in order to ensure safety, the control system will prohibit all actions. Disregard if not lithium.
PCU: n1 ECU: 1xxx	Right Drive Motor Controller Fault	Controller Dependent	Motor controller processing.
PCU: n2 ECU: 2xxx	Left Drive Motor Controller Fault	Controller Dependent	Motor controller processing.
PCU: n3 ECU: 3xxx	Pump Motor Controller Fault	Controller Dependent	Motor controller processing.
PCU: UP	Platform up limit position	Warning Only	The system prompts that the platform has reached the upper limit and only gives an alarm.

Motor Controller Fault Codes

E700 receives the fault code sent by the motor controller and displays it, but it does not perform any protection actions or record it in the log. The fault codes of the motor controller are as follows: (1xxx represents the right drive motor controller, 2xxx represents the left drive motor controller, 3xxx represents the pump motor controller, 4xxx represents the steer motor controller).

Code	Fault name	Solution
X008	WATCHDOG	Replace the motor controller.
X017	LOGIC FAILURE #3	Replace the motor controller.
X018	LOGIC FAILURE #2	Replace the motor controller.
X019	LOGIC FAILURE #1	<ol style="list-style-type: none"> 1. Check the battery voltage. 2. Replace the motor controller.
X028	PUMP VMN LOW	
X029	PUMP VMN HIGH	
X030	VMN LOW	<ol style="list-style-type: none"> 1. Motor wiring problem. 2. Check for shorts inside motor. 3. Possible motor-controller problem.

Code	Fault name	Solution
X031	VMN HIGH	<ol style="list-style-type: none"> 1. Motor wiring problem. 2. Check for shorts inside motor. 3. Possible motor-controller problem.
X037	CONTACTOR CLOSED	<ol style="list-style-type: none"> 1. Contactor points stuck closed. 2. The large wire of contactor is short-circuited to the positive terminal. 3. Possible controller problem.
X038	CONTACTOR OPEN	<ol style="list-style-type: none"> 1. Contactor points broken or unable to close. 2. No power to signal wire to contactor or not connected. 3. Big fuse is broken. 4. Possible motor controller problem.
X052	PUMP I=0 EVER	
X053	STBY I HIGH	Motor controller internal current sensor hardware problem, replace the motor controller.
X060	CAPACITOR CHARGE	<ol style="list-style-type: none"> 1. Check for mis-wired motor controller large terminals. 2. Key Switch output shorted. 3. Possible motor controller failure.
X062 X065	TH. PROTECTION MOTOR TEMPERAT.	<ol style="list-style-type: none"> 1. Wait to cool down. 2. If motor controller is cool, replace the motor controller. Wait for the motor to cool down.
X066	BATTERY LOW	Charge the battery.
X074	DRIVER SHORTED	<ol style="list-style-type: none"> 1. The contactor coil is shorted. 2. The coil of the contactor has B+ before it should. 3. Possible motor controller failure.
X075	CONTACTOR DRIVER	<ol style="list-style-type: none"> 1. Contactor coil is broken. 2. Coil wiring error. 3. Possible motor controller problem.
X078	VACC NOT OK	
X079	INCORRECT START	
X080	FORW + BACK	Both directions powered, check the ECU.
X086	PEDAL WIRE KO	
X152	IIC BUS ERROR	Replace the motor controller.
X153	ENCODER ERROR XX	<ol style="list-style-type: none"> 1. The motor encoder is broken. 2. Motor unable to turn. 3. Possible motor controller problem.
X154	OUT MISMATCHXX	Replace motor controller.
X155	SP MISMATCHXX	Replace motor controller.
X157	INPUT MISMATCHXX	Replace motor controller.
X158	NOT RDY DRV.POW.	Replace motor controller.
X159	HVIL FAIL	<ol style="list-style-type: none"> 1. The motor encoder is broken. 2. Motor unable to turn. 3. Possible motor controller problem.
X160	SENS BAT TEMP KO	<ol style="list-style-type: none"> 1. The motor encoder is broken. 2. Motor unable to turn. 3. Possible motor controller problem.
X161	RPM HIGH	<ol style="list-style-type: none"> 1. The motor encoder is broken. 2. Motor unable to turn. 3. Possible motor controller problem.
X162	BUMPER STOP	<ol style="list-style-type: none"> 1. The motor encoder is broken. 2. Motor unable to turn. 3. Possible motor controller problem.
X163	ED SLIP MISMATCH	<ol style="list-style-type: none"> 1. The motor encoder is broken. 2. Motor unable to turn. 3. Possible motor controller problem.
X164	PWM ACQ. ERROR	<ol style="list-style-type: none"> 1. The motor encoder is broken. 2. Motor unable to turn. 3. Possible motor controller problem.

Code	Fault name	Solution
X168	SIN/COS D.ERR XX	<ol style="list-style-type: none"> 1. The motor encoder is broken. 2. Motor unable to turn. 3. Possible motor controller problem.
X169	ENCODER D.ERR XX	<ol style="list-style-type: none"> 1. The motor encoder is broken. 2. Motor unable to turn. 3. Possible motor controller problem.
X170	WRONG KEY VOLT.	<ol style="list-style-type: none"> 1. Detect whether there is a sudden change in voltage. 2. Check motor control wiring.
X171	ACQUIRING A.S.	<ol style="list-style-type: none"> 1. The encoder is broken. 2. Motor stuck more than a certain time. 3. Replace the motor controller.
X172	ACQUIRE ABORT	<ol style="list-style-type: none"> 1. The encoder is broken. 2. Motor stuck more than a certain time. 3. Replace the motor controller.
X173	ACQUIRE END	<ol style="list-style-type: none"> 1. The encoder is broken. 2. Motor stuck more than a certain time. 3. Replace the motor controller.
X174	OFFSET SPD.SENS.	Contact ZAPI engineer.
X175	SPEED FB. ERROR	<ol style="list-style-type: none"> 1. The motor encoder is broken. 2. Motor unable to turn. 3. Possible motor controller problem.
X176	HOME SENS.ERR XX	<ol style="list-style-type: none"> 1. The motor encoder is broken. 2. Motor unable to turn. 3. Possible motor controller problem.
X177	COIL SHOR. EB.	<ol style="list-style-type: none"> 1. Check if the brake wiring is short circuit. 2. Replace the motor controller.
X178	MOTOR TEMP. STOP	<ol style="list-style-type: none"> 1. Whether the motor temperature is actually too high. 2. Whether the motor temperature sensor wiring open circuit. 3. Replace the motor controller.
X179	STEER SENSOR KO	Check voltage and wiring of steering potentiometer.
X180	OVERLOAD	<ol style="list-style-type: none"> 1. Problem with motor/encoder wiring. 2. The motor has excessive resistance to rotation. 3. Possible motor controller problem.
X181	WRONG ENC SET	<ol style="list-style-type: none"> 1. The motor encoder is broken. 2. Motor unable to turn. 3. Possible motor controller problem.
X185	TILLER ERROR	
X186	WAIT MOT.P STILL	
X187	LIFT+LOWER	
X188	INT. CANBUSKO	Replace the motor controller.
X189	PUMP INC START	
X190	PUMP VMN NOT OK	
X191	PUMP VACC NOT OK	
X192	PUMP VACC RANGE	
X193	SMARTDRIVER KO	<ol style="list-style-type: none"> 1. Check the brake positive wiring. 2. Check A13 of drive-motor controller, check A3 of pump-motor controller. 3. Parameter in controller is abnormal. 4. Replace the motor controller.
X194	AUX BATT. SHORT.	<ol style="list-style-type: none"> 1. Parameter setting problem. 2. Check if the brake positive wiring and voltage are normal.
X195	POS. EB. SHORTED	<ol style="list-style-type: none"> 1. Check the brake positive wiring. 2. Check A13 of drive-control Check A13 of pump control. 3. Motor controller parameter setting problem. 4. Replace the motor controller.
X196	MOT.PHASE SH.	<ol style="list-style-type: none"> 1. Check whether motor wiring is normal, whether there is leakage to case or water in motor. 2. Possible motor controller problem.

Code	Fault name	Solution
X197	WRONG SLAVE VER.	Flash the correct software.
X198	M/S PAR CHK MISM	Replace Motor controller.
X199	PARAM TRANSFER	Wait a few seconds and power on again.
X200	VDC OFF SHORTED	<ol style="list-style-type: none"> 1. Check the battery. 2. Check motor controller connections.
X201	TORQUE PROFILE	Replace motor controller.
X202	VDC LINK OVERV.	<ol style="list-style-type: none"> 1. Check for abnormal regenerative braking. 2. One of the external capacitors is damaged. 3. Replace motor controller.
X204	BRAKE RUN OUT	
X205	EPS RELAY OPEN	
X206	INIT VMN HIGH	<ol style="list-style-type: none"> 1. Motor wiring problem. 2. Check whether the motor voltage is leaking to case. 3. Possible motor-controller problem.
X207	INIT VMN LOW	<ol style="list-style-type: none"> 1. Motor wiring problem. 2. Check whether the motor is leaking. 3. Possible motor-controller problem.
X208	EEPROM KO	
X209	PARAM RESTORE	Restart the machine.
X210	WRONG RAM MEM.	<ol style="list-style-type: none"> 1. Power on key switch again. 2. After power on, the problem is still there, replace the motor controller.
X211	STALL ROTOR	<ol style="list-style-type: none"> 1. Excessive resistance to motor shaft rotation. 2. Motor mechanical problem.
X212	POWER MISMATCH	Replace Motor controller.
X213	POSITIVE LC OPEN	<ol style="list-style-type: none"> 1. Contactor coil positive wiring problem. 2. Possible motor controller problem.
X214	EVP COIL OPEN	<ol style="list-style-type: none"> 1. Check the wiring to valve coils. 2. Possible motor controller problem.
X215	EVP DRIV. SHORT.	<ol style="list-style-type: none"> 1. Check the wiring to valve coils. 2. Possible motor controller problem.
X216	EB. COIL OPEN	<ol style="list-style-type: none"> 1. Check for brake coil open circuit. 2. Check if the wiring is open circuit to brake coil. 3. Replace the motor controller.
X217	PEB NOT OK	<ol style="list-style-type: none"> 1. Check the brake positive wiring. 2. Check A13 of drive-motor controller, check A3 of pump-motor controller. 3. Parameter in controller is abnormal. 4. Replace the motor controller.
X218	SENS MOT TEMP KO	<ol style="list-style-type: none"> 1. The actual temperature is too high, let cool. 2. Motor temperature sensor problem or wiring problem.
X220	VKEY OFF SHORTED	<ol style="list-style-type: none"> 1. Check the battery. 2. Possible motor controller problem.
X221	HANDBRAKE	
X223	COIL SHOR.MC	<ol style="list-style-type: none"> 1. Contactor coil short circuit. 2. The contactor signal wire is short-circuited. 3. Possible motor controller problem.
X224	WAITING FOR NODE	Check another node.
X224	WAITING FOR NODE	
X224	WAITING FOR NODE	
X226	VACC OUT RANGE	
X227	HW FAULT	Replace the motor controller.
X228	TILLER OPEN	
X229	HW FAULT EB.	Replace the motor controller.
X230	LC COIL OPEN	<ol style="list-style-type: none"> 1. The coil wire is disconnected. 2. Possible motor controller Problem.

Code	Fault name	Solution
X231	PUMP I NO ZERO	
X232	CONT. DRV. EV	<ol style="list-style-type: none"> 1. Check the ECU options settings. 2. Possible motor controller problem.
X233	POWERMOS SHORTED	<ol style="list-style-type: none"> 1. Motor wiring problem. 2. Check for motor voltage leaking to case. 3. Possible motor-controller problem.
X234	DRV. SHOR. EV	<ol style="list-style-type: none"> 1. Check the ECU options. 2. Replace the motor controller.
X235	CTRAP THRESHOLD	Replace the motor controller.
X236	CURRENT GAIN	Replace the motor controller.
X237	ANALOG INPUT	Replace the motor controller.
X238	HW FAULT EV.	
X239	CONTROLLER MISM.	Check ECU version.
X240	EVP DRIVER OPEN	<ol style="list-style-type: none"> 1. Check the wiring to valve block. 2. Possible motor controller problem.
X241	COIL SHOR. EVAUX	<ol style="list-style-type: none"> 1. Check the wiring to valve block. 2. Replace the motor controller.
X242	OPEN COIL EV.	<ol style="list-style-type: none"> 1. Check the wiring to valve block. 2. Replace the motor controller.
X243	THROTTLE PROG.	
X244	WARNING SLAVE	Check the specific fault of the slave-controller.
X245	IQMISMATCHED	Replace motor controller.
X246	EB. DRIV.OPEN	Replace motor controller.
X247	DATA ACQUISITION	Replace motor controller.
X248	NO CAN MSG.	<ol style="list-style-type: none"> 1. Interference problem, check CAN resistance setting, interference level. 2. For other software setting problems, you need to contact MEC Aerial Work Platforms.
X249	CHECK UP NEEDED	Change the "CHECK UP DONE" parameter to ON.
X250	THERMIC SENS. KO	Replace the motor controller.
X251	WRONG SET BAT.	<ol style="list-style-type: none"> 1. The parameter "battery type" is set incorrectly. 2. External voltage is too low or too high.
X253	FIELD ORIENT. KO	Replace motor controller.
X254	EB. DRIV.SHRT.	<ol style="list-style-type: none"> 1. Check if the brake wiring is shorted. 2. The motor-controller is broken.

Electrical Schematic

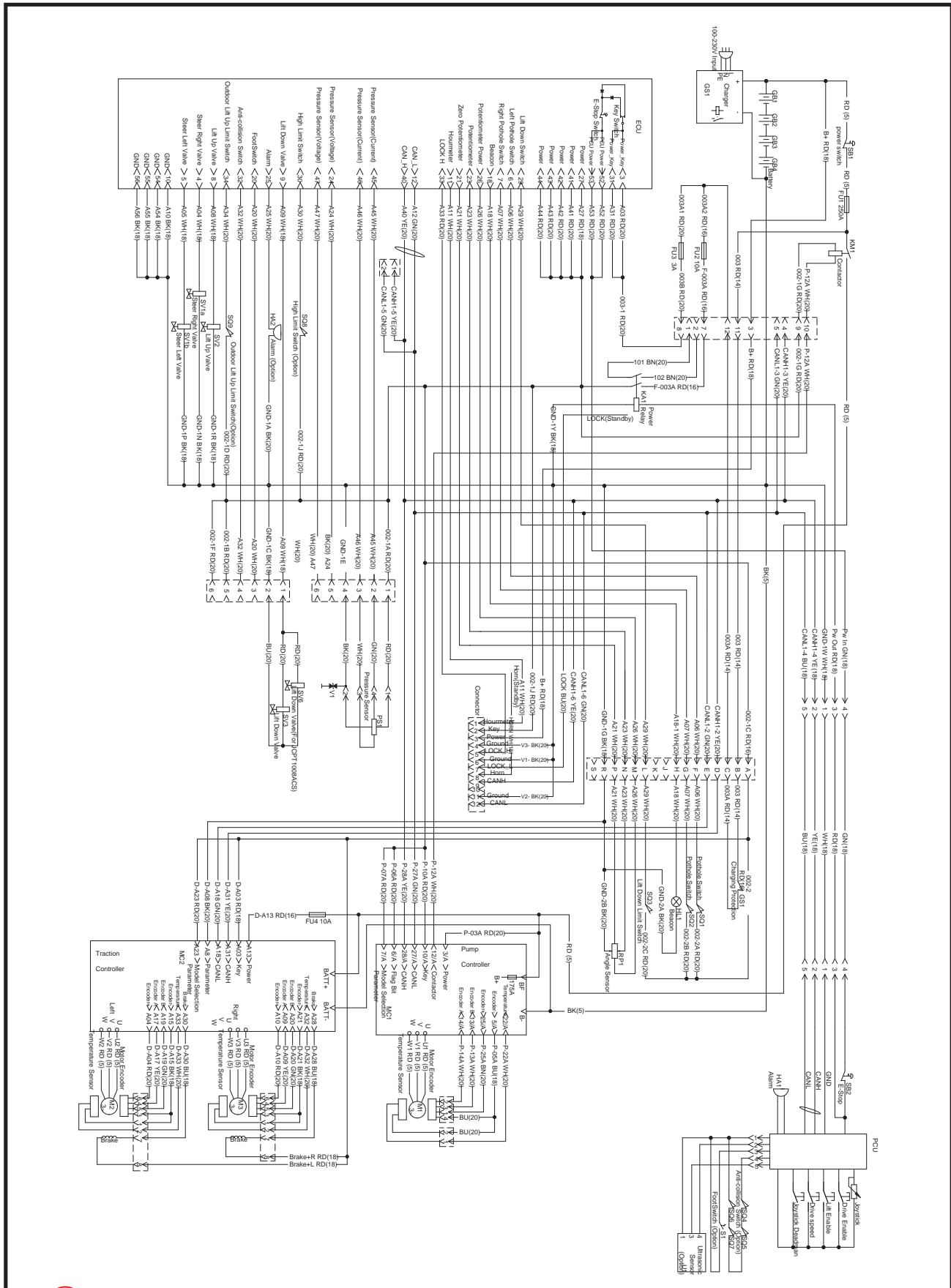

ILLUSTRATION No. **Micro26-XD**
 ART_6373

Electrical Schematic



Parts Introduction

This Parts sections consists of illustrated parts sections and is designed to provide you, the customer, with illustrations and the list of associated parts needed to properly maintain the MEC self-propelled aerial work platform. When used in conjunction with the Service section in this manual and the Operator's Manual (provided separately), this manual will assist you in making necessary adjustments and repairs, and identifying and ordering the correct replacement parts.

All parts represented here are manufactured and supplied in accordance with MEC quality standards.

We recommend that you use genuine MEC parts to ensure proper operation and reliable performance.

To obtain maximum benefits from your MEC Aerial Work Platforms, always follow the proper operating and maintenance procedures. Only trained authorized personnel should be allowed to operate or service this machine. Service personnel should read and study the Operator's, and the Service and Parts Manuals in order to gain a thorough understanding of the unit prior to making any repairs.

Steer Linkage and Wheels Assembly

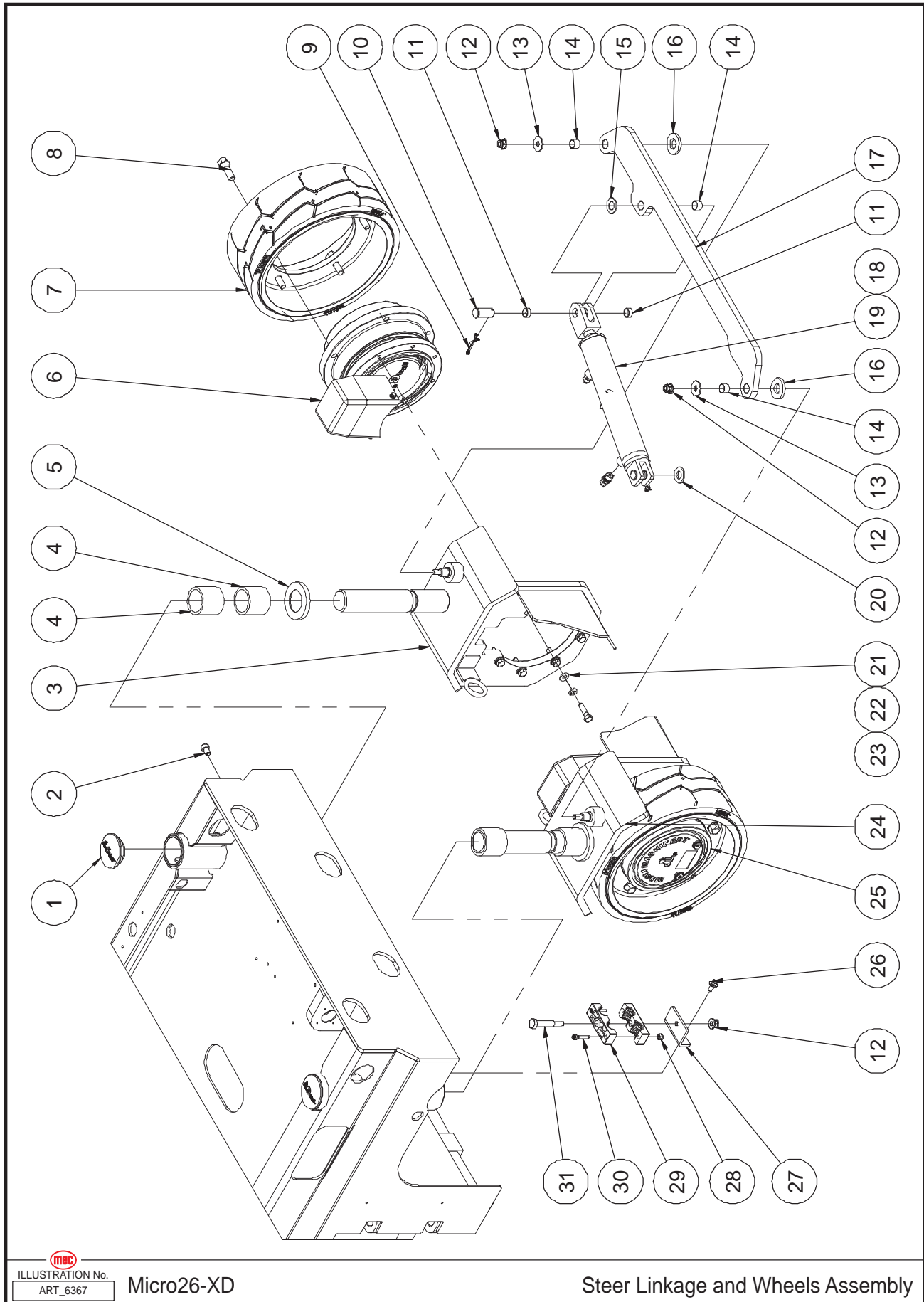
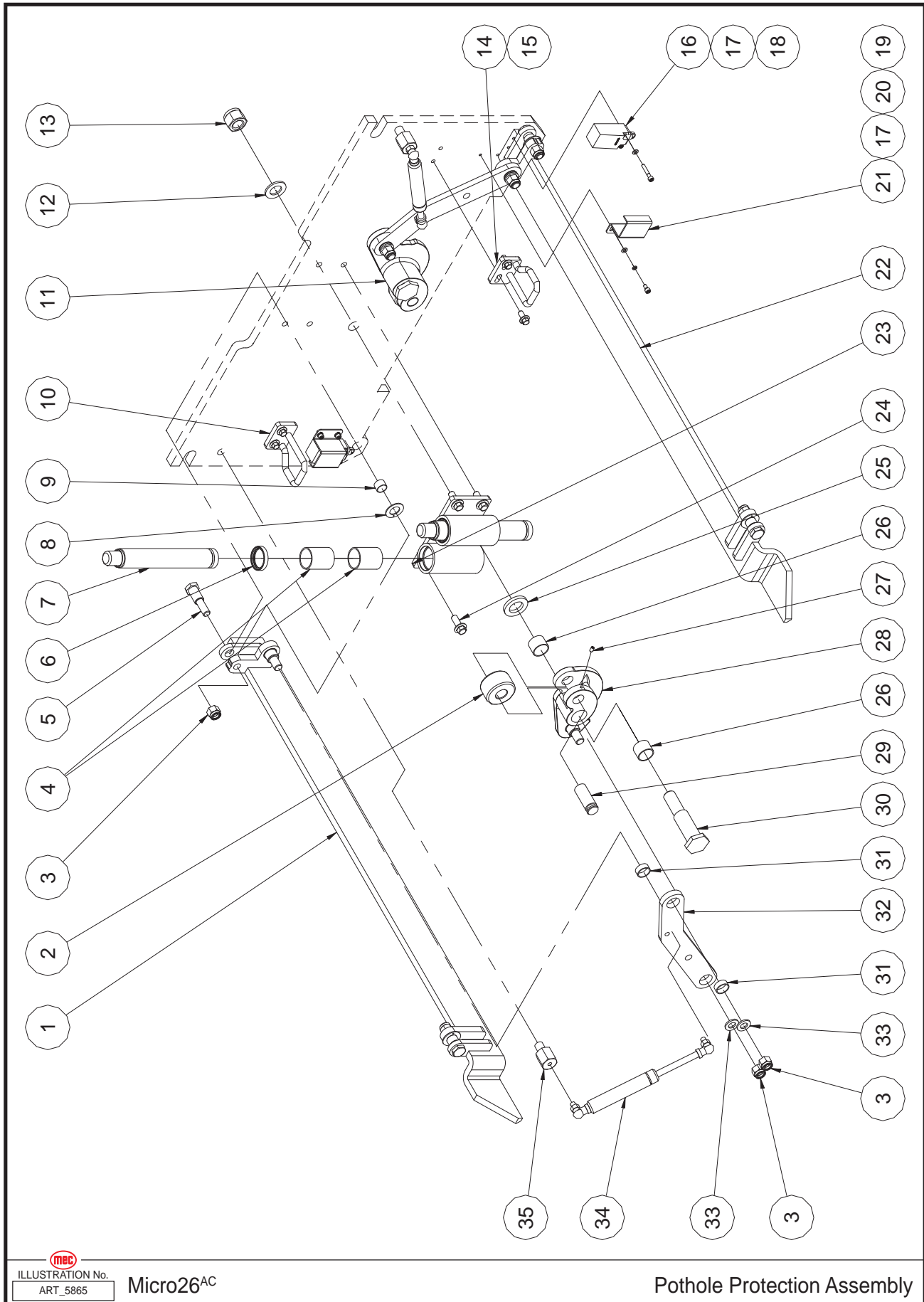



ILLUSTRATION No. **Micro26-XD**
ART_6367

Steer Linkage and Wheels Assembly

Item	Part Number	Description	Qty.
1	45422	Cover	2
2	41794	Screw	2
3	49191	Steer Yoke Weldment	1
4	49192	Bearing	4
5	49193	Washer	2
6	45418	Left Drive Motor Assembly	1
--	47486	Left Motor Cover	1
--	47483	Drive Motor Assembly	1
--	47490	Motor (With Brake)	1
--	46235	Reducer	1
--	46236	Brake	1
7	46237	Wheel	2
8	46238	Wheel Bolt	10
9	43563	Cotter Pin	2
10	41321	Pin	2
11	41225	Bearing	4
12	50311	Nut NNYL M10-1.50 Flange ZP	2
13	53375	WSHR M10 Flat Fender Washer ZP	2
14	41210	Bearing	4
15	41222	Bearing	1
16	41814	Washer	2
17	49194	Tie Rod	1
18	43076	Straight Fitting	2
19	41593	Steer Cylinder Assembly	1
--	41594	Seal Kit	1
20	43564	Washer	1
21	53317	WSHR 3/8 Standard Flat Narrow Washer ZP	14
22	53316	WSHR 3/8 Spring Washer ZP	14
23	53376	Screw HHCS 3/8-16 x 1 3/8 ZP	14
24	49195	Steer Yoke Weldment	1
25	45419	Right Drive Motor Assembly	1
--	47485	Right Motor Cover	1
--	47483	Drive Motor Assembly	1
--	47490	Motor (With Brake)	1
--	46235	Reducer	1
--	46236	Brake	1
26	53194	Screw HHCS M08-1.25 x 16 Serrated Flange ZP	2
27	44343	Hose Clamp Support	1
28	50047	Nut NNYL M06-1.00 ZP	2
29	45313	Hose Clamp	2
30	53207	Screw SHCS M06-1.00 x 30 ZP	2
31	45420	Bolt	1

Pothole Protection Assembly

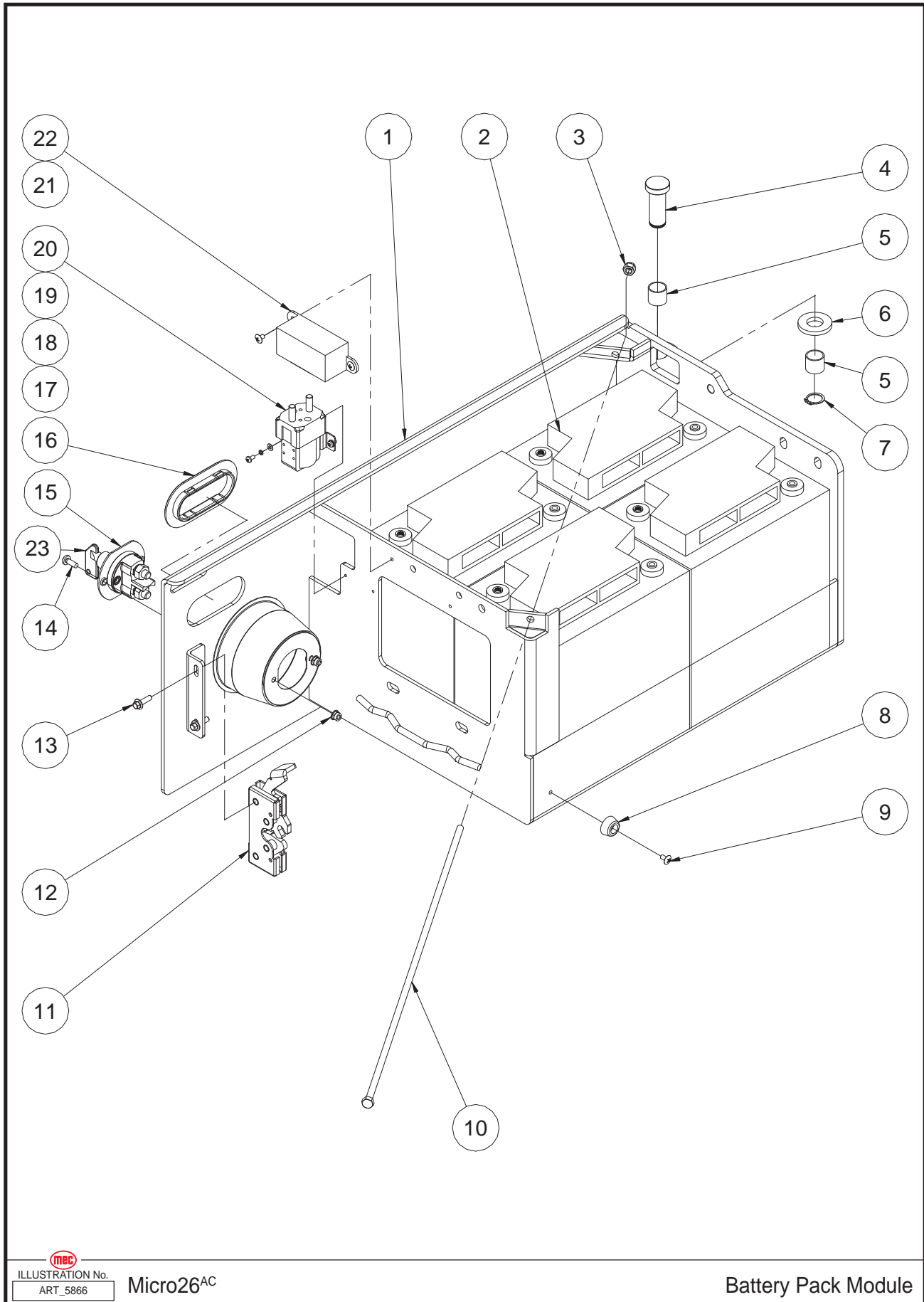



 ILLUSTRATION No. **Micro26^{AC}**
ART_5865

Pothole Protection Assembly

Item	Part Number	Description	Qty.
1	49196	Pothole Guard Weldment	1
2	41049	Roller	2
3	50050	Nut NNYL M12-1.75 ZP	8
4	43568	Bearing	4
5	41604	Pin	4
6	44889	Seal	2
7	43569	Pothole Hole Pusher Assembly	2
8	41222	Bearing	4
9	41210	Bearing	4
10	41807	Lock Clasp	1
11	47093	Linkage Weldment	1
12	50005	WSHR M20 Standard Flat Washer ZP	2
13	50052	Nut NNYL M20-2.50 ZP	2
14	41808	Lock Clasp	1
15	53194	Screw HHCS M08-1.25 x 16 Serrated Flange ZP	4
16	46242	Limit Switch	2
17	53038	WSHR M05 Standard Flat Washer ZP	8
18	53171	Screw SHCS M05-0.80 x 30 ZP	4
19	53173	Screw SHCS M05-0.80 x 10 ZP	4
20	53043	WSHR M05 Spring Washer ZP	4
21	41035	Switch Cover	2
22	49197	Pothole Guard Weldment	1
23	44891	Pothole Guide	1
24	50429	Screw HHCS M10-1.50 x 25 Serrated Flange ZP	4
25	41040	Washer	2
26	41046	Bearing	4
27	53283	Set Screw M05-0.80 x 10 Cone Point ZP	2
28	47092	Linkage Weldment	1
29	41048	Pin	2
30	41047	Pin	2
31	41214	Bearing	4
32	49198	Pothole Link Plate	2
33	50003	WSHR M12 Standard Flat Washer ZP	4
34	41045	Gas Shock	2
35	43573	Gas Shock Strut	2

Battery Pack Module



 ILLUSTRATION No. ART_5866 **Micro26^{AC}**

Battery Pack Module

Item	Part Number	Description	Qty.
1	46243	Battery Tray Weldment	1
2	46244	Battery	4
3	50048	Nut NNYL M08-1.25 ZP	1
4	41813	Hinge Pin	2
5	41037	Bearing	4
6	41814	Washer	2
7	43574	Circlips	2
8	41120	Bumper	1
9	53265	Screw THMS M05-0.80 x 10 ZP	1
10	41408	Threaded Rod	1
11	42896	Latch (Left)	1
12	50568	Nut NNYL M06-1.00 Flange ZP	2
13	53255	Screw HHCS M06-1.00 x 20 Serrated Flange ZP	2
14	53231	Screw PHMS M06-1.00 x 16 ZP	2
15	46245	Power Switch	1
16	41068	Handle Hole Ring	1
17	53276	Screw PHMS M04-0.70 x 8 ZP	2
18	53062	WSHR M04 Spring Washer ZP	2
19	50284	WSHR M04 Standard Flat Washer ZP	2
20	41331	Contactora	1
21	53451	Screw THMS M05-0.80 x 8 ZP	2
22	46246	250A Fuse Assembly	1
--	46247	250A Fuse	1
--	46248	Fuse Block	1
23	45942	Key, Red Battery Switch	1

Power Unit Module

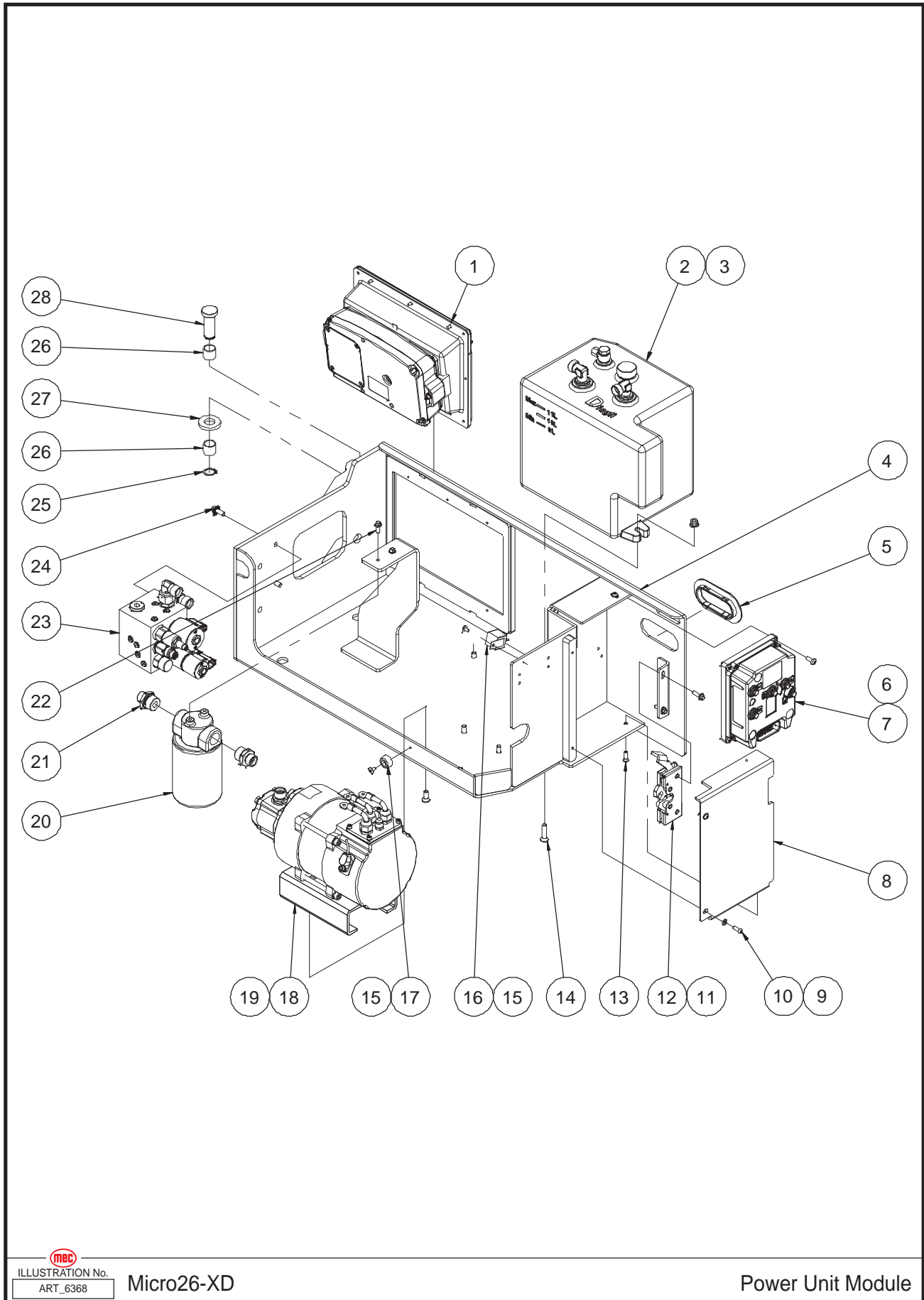
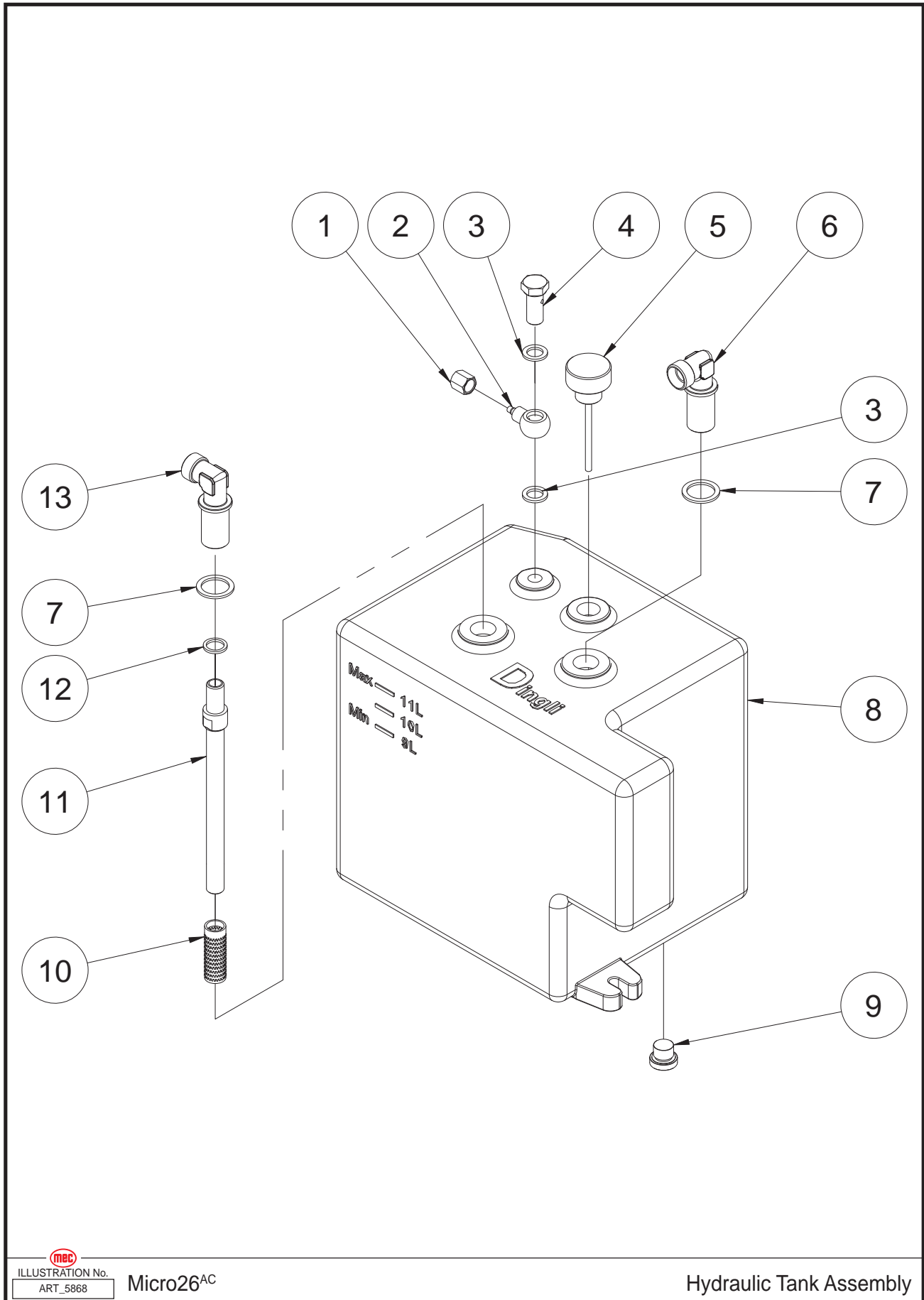



 ILLUSTRATION No. **Micro26-XD**
ART_6368

Power Unit Module

Item	Part Number	Description	Qty.
1	REF	Ground Control and Cover Assembly (Refer to page 60)	1
2	49199	Hydraulic Tank Assembly (Refer to page 58)	1
3	50313	Nut NNYL M08-1.25 Flange ZP	2
4	49200	Hydraulic Tray Weldment	1
5	41068	Handle Hole Ring	1
6	53231	Screw PHMS M06-1.00 x 16 ZP	4
7	46250	Motor Controller	1
8	46251	Cover	3
9	50000	WSHR M06 Standard Flat Washer ZP	1
10	53448	Screw BHCS M06-1.00 x 16 ZP	3
11	53255	Screw HHCS M06-1.00 x 20 Serrated Flange ZP	2
12	41067	Latch (Right)	1
13	50561	Screw CSCS M06-1.00 x 20 ZP	1
14	53071	Screw CSCS M08-1.25 x 35 ZP	2
15	53265	Screw THMS M05-0.80 x 10 ZP	2
16	46252	Relay	1
17	41120	Bumper	1
18	REF	Pump Motor Assembly (Refer to page 64)	1
19	53282	Screw CSCS M08-1.25 x 20 ZP	4
20	41077	Filter Assembly	1
21	43576	Straight Fitting	2
22	53256	Screw HHCS M06-1.00 x 16 Serrated Flange ZP	2
23	REF	Function Manifold (Refer to page 94)	1
24	53257	Screw HHCS M08-1.25 x 20 Serrated Flange ZP	4
25	43574	Circlips	2
26	41037	Bearing	4
27	41814	Washer	2
28	41813	Hinge Pin	2

Hydraulic Tank Assembly

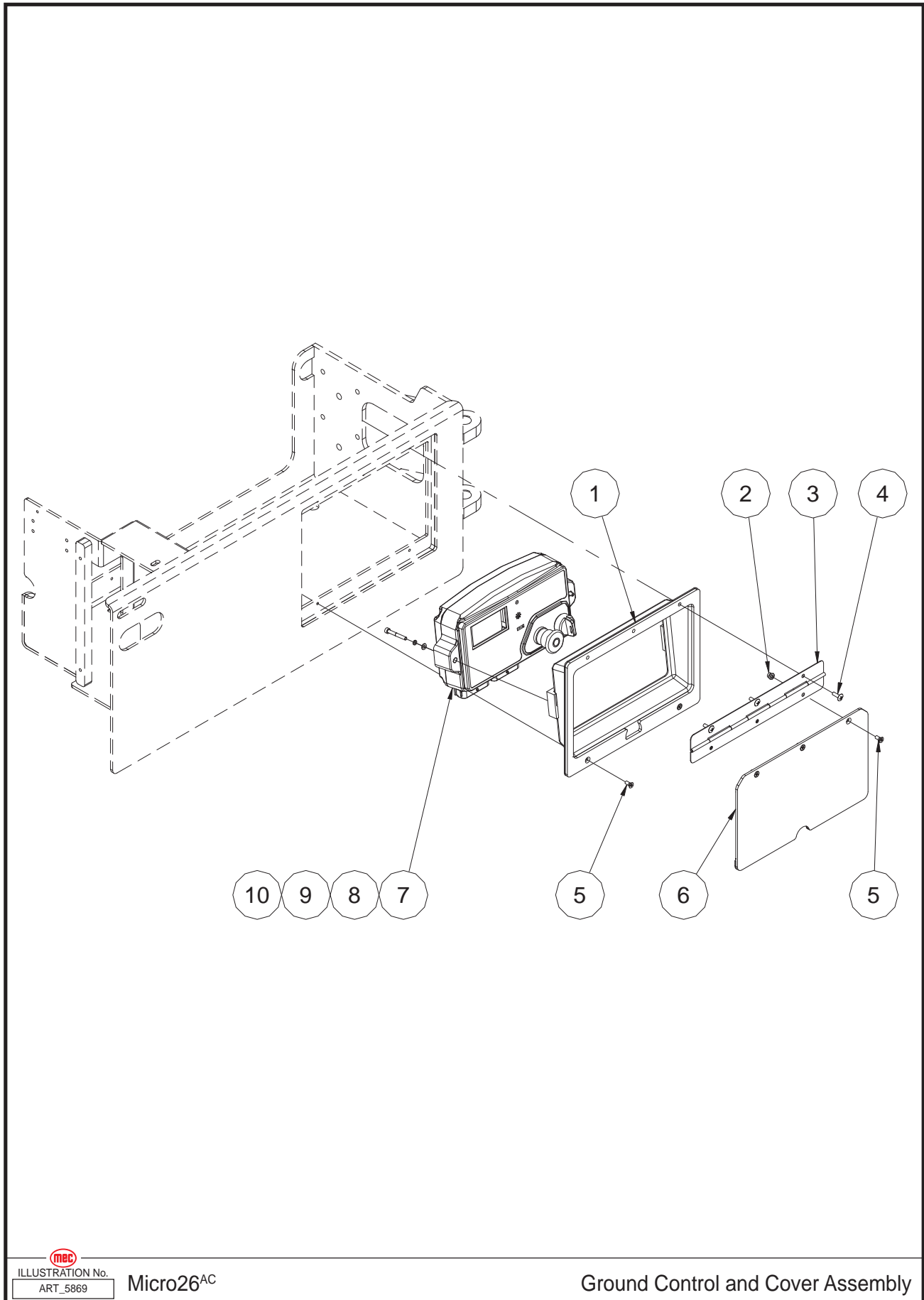



 ILLUSTRATION No. ART_5868 Micro26^{AC}

Hydraulic Tank Assembly

Item	Part Number	Description	Qty.
1	41413	Nut	1
2	41167	Fitting	1
3	44002	Washer	2
4	41166	Fitting	1
5	41082	Breather	1
6	41085	Fitting	1
7	41412	Tank	2
8	46254	Tank	1
9	41087	Plug	1
10	41824	Filter	1
11	44568	Suction Pipe	1
12	44567	Washer	1
13	41826	Fitting	1

Ground Control and Cover Assembly



ILLUSTRATION No. **Micro26^{AC}**
ART_5869

Ground Control and Cover Assembly

Item	Part Number	Description	Qty.
1	46255	Ground Control Bracket	1
2	53281	Nut NNYL M05-0.80 Flange ZP	3
3	46256	Hinge	1
4	53224	Screw THMS M05-0.80 x 12 ZP	3
5	53279	Screw CSCS M05-0.80 x 12 ZP	5
6	46257	Cover	1
7	46313	Ground Control Assembly (Refer to page 62)	1
8	53038	WSHR M05 Standard Flat Washer ZP	2
9	53043	WSHR M05 Spring Washer ZP	2
10	53067	Screw SHCS M05-0.80 x 40 ZP	2

REF - Reference

Ground Control Assembly

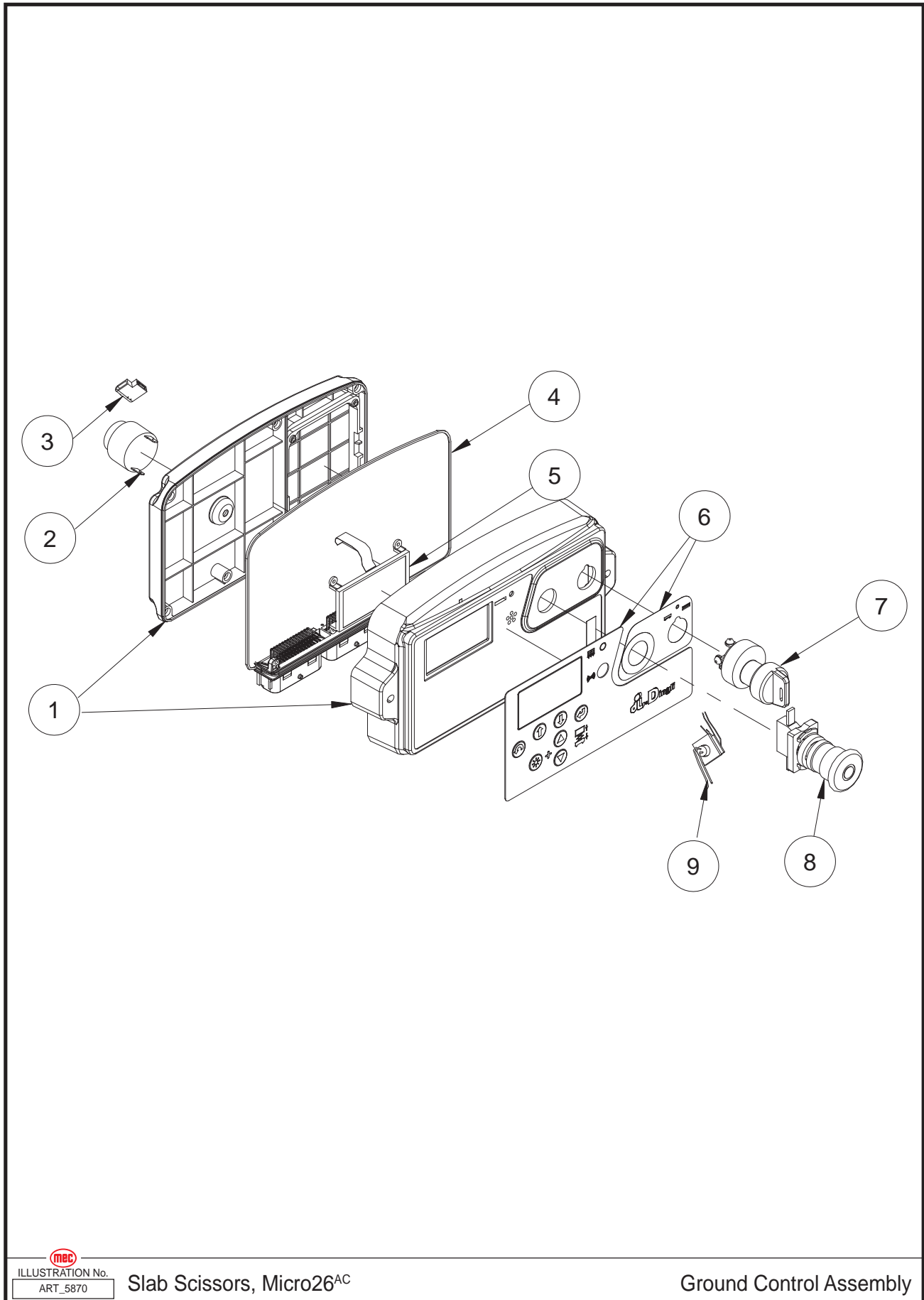

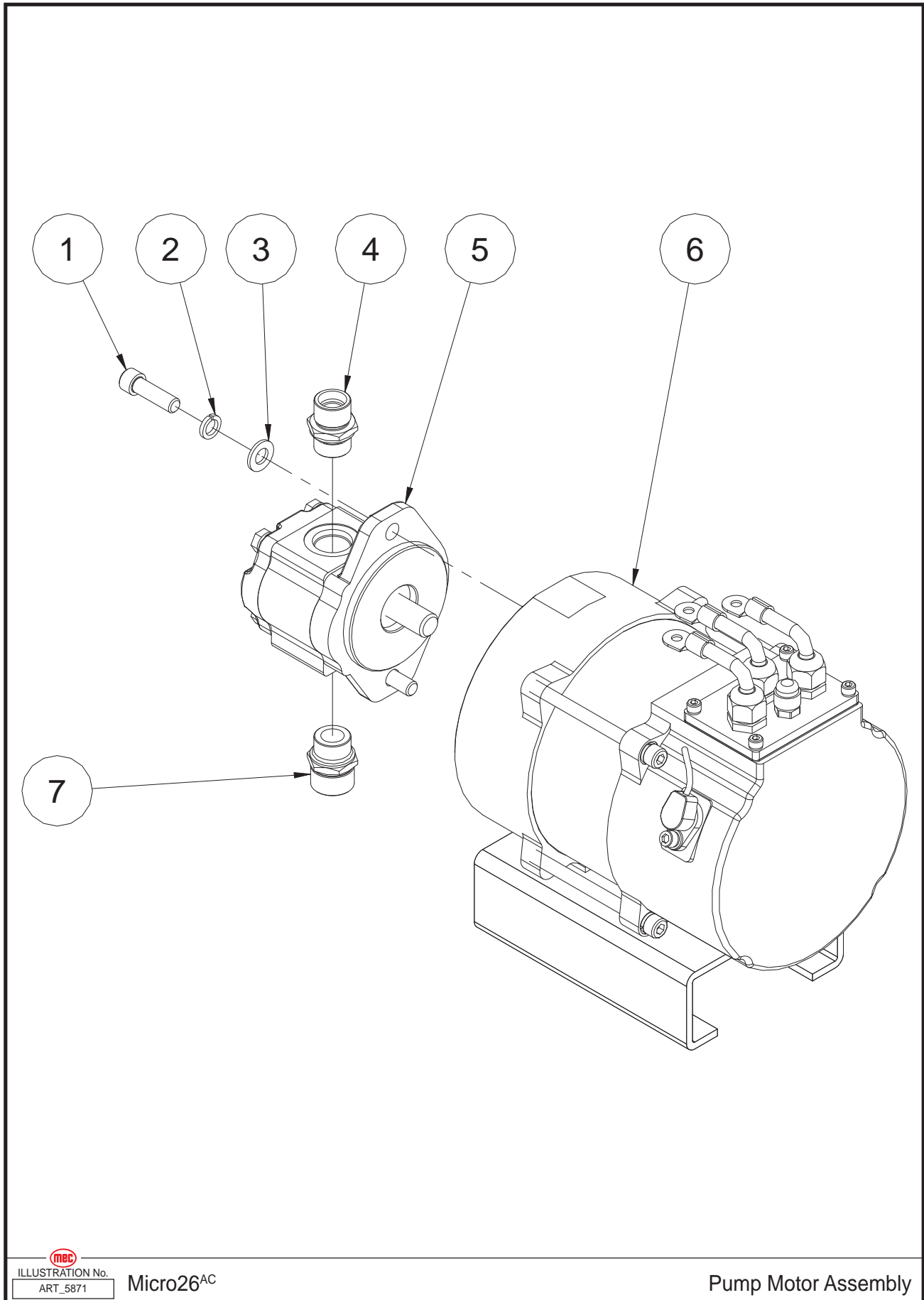

ILLUSTRATION No.
ART_5870

Slab Scissors, Micro26^{AC}

Ground Control Assembly

Item	Part Number	Description	Qty.
1	46258	Shell Components	1
2	41568	Alarm	1
--	43631	Alarm Nut	1
3	44691	Alarm Harness	1
4	--	--	--
5	44693	Display	1
6	44795	Decal, Ground Control Panel	1
7	41418	Key Switch	1
--	91574	Key	1
8	41157	Emergency Stop Switch	1
--	43632	Red Mushroom Head	1
--	43633	Base With 1 NO Contact	1
9	44694	EMS Switch Harness	1

Pump Motor Assembly

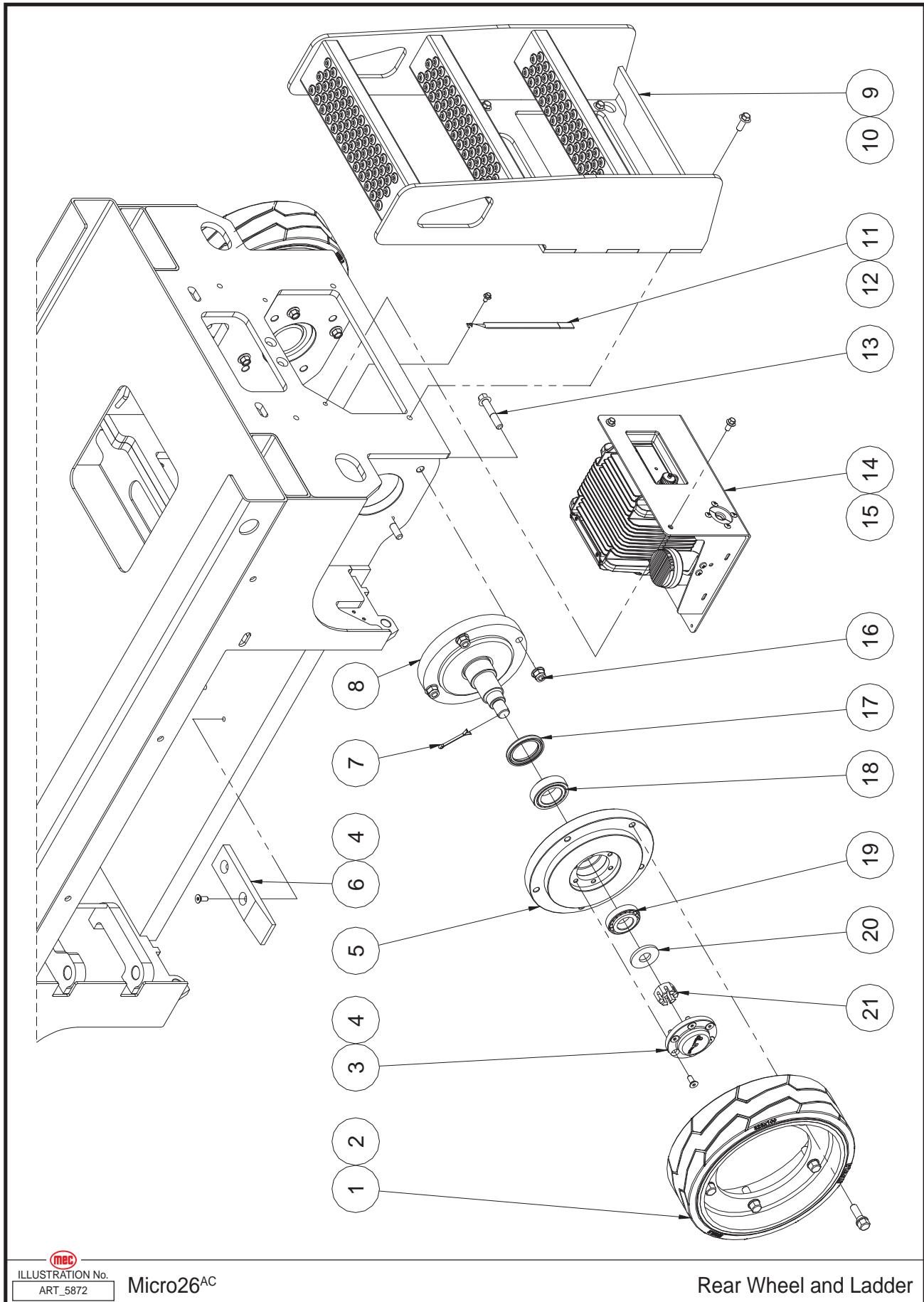



 ILLUSTRATION No. **Micro26^{AC}**
ART_5871

Pump Motor Assembly

Item	Part Number	Description	Qty.
1	53315	Screw SHCS 3/8-24 x 1 1/4 ZP	2
2	53054	WSHR M10 Spring Washer ZP	2
3	50002	WSHR M10 Standard Flat Washer ZP	2
4	43205	Straight Fitting	1
5	41426	Pump	1
6	46259	Motor	1
7	46260	Straight Fitting	1

Rear Wheel and Ladder



 ILLUSTRATION No. **Micro26^{AC}**
ART_5872

Rear Wheel and Ladder

Item	Part Number	Description	Qty.
1	46237	Wheel	2
2	46238	Bolt	10
3	41237	Cap	2
4	53282	Screw CSCS M08-1.25 x 20 ZP	16
5	41025	Bearing Seat	2
6	41002	Spacer	2
7	43585	Cotter Pin	2
8	43586	Spindle	2
9	43587	Ladder	1
10	50429	Screw HHCS M10-1.50 x 25 Serrated Flange ZP	4
11	41003	Ground Strap	1
12	53260	Screw HHCS M06-1.00 x 10 Serrated Flange ZP	1
13	53290	Screw HHCS M12-1.75 x 65 Flange ZP	8
14	REF	Charger Assembly (Refer to page 68)	1
15	53194	Screw HHCS M08-1.25 x 16 Serrated Flange ZP	2
16	53261	Nut NNYL M12-1.75 Flange ZP	8
17	43588	Seal	2
18	41029	Bearing	2
19	41024	Bearing	2
20	41304	Washer	2
21	53262	Castle Nut M22-1.50 ZP	2

REF - Reference

Charger Assembly

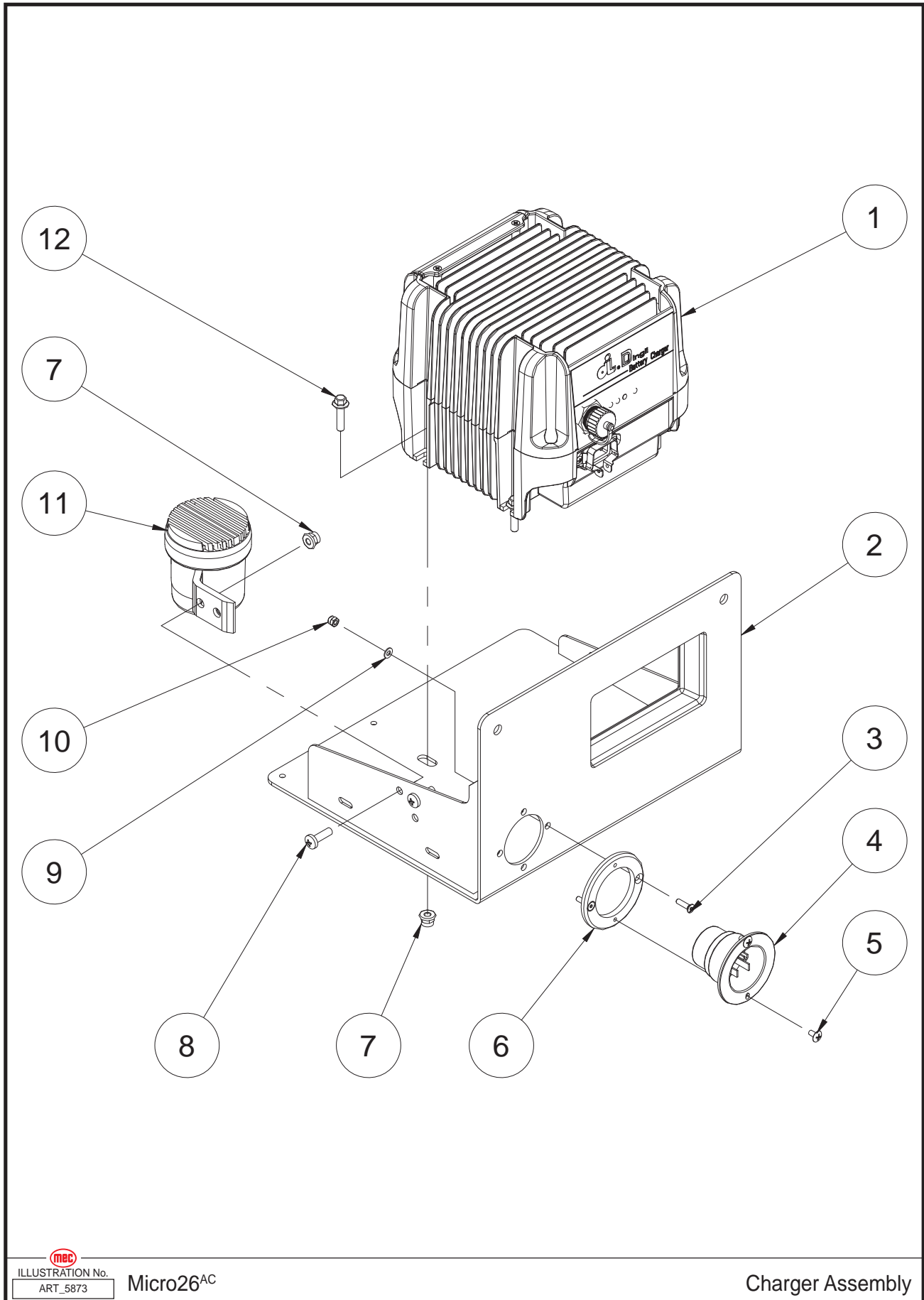

 ILLUSTRATION No. ART_5873 Micro26^{AC}

Charger Assembly

Item	Part Number	Description	Qty.
1	42903	Charger	1
2	46262	Charger Bracket Weldment	1
3	53221	Screw CSCS M04-0.70 x 16 ZP	2
4	41575	Plug	1
5	53263	Screw THMS M04-0.70 x 8 ZP	2
6	43591	Plug Bracket	1
7	50568	Nut NNYL M06-1.00 Flange ZP	6
8	53264	Screw PHMS M06-1.00 x 20 ZP	2
9	50284	WSHR M04 Standard Flat Washer ZP	2
10	50285	Nut NNYL M04-0.70 ZP	2
11	46263	Battery Alarm	1
12	53432	Screw HHCS M06-1.00 x 25 Serrated Flange ZP	4

Chassis Accessory Installation

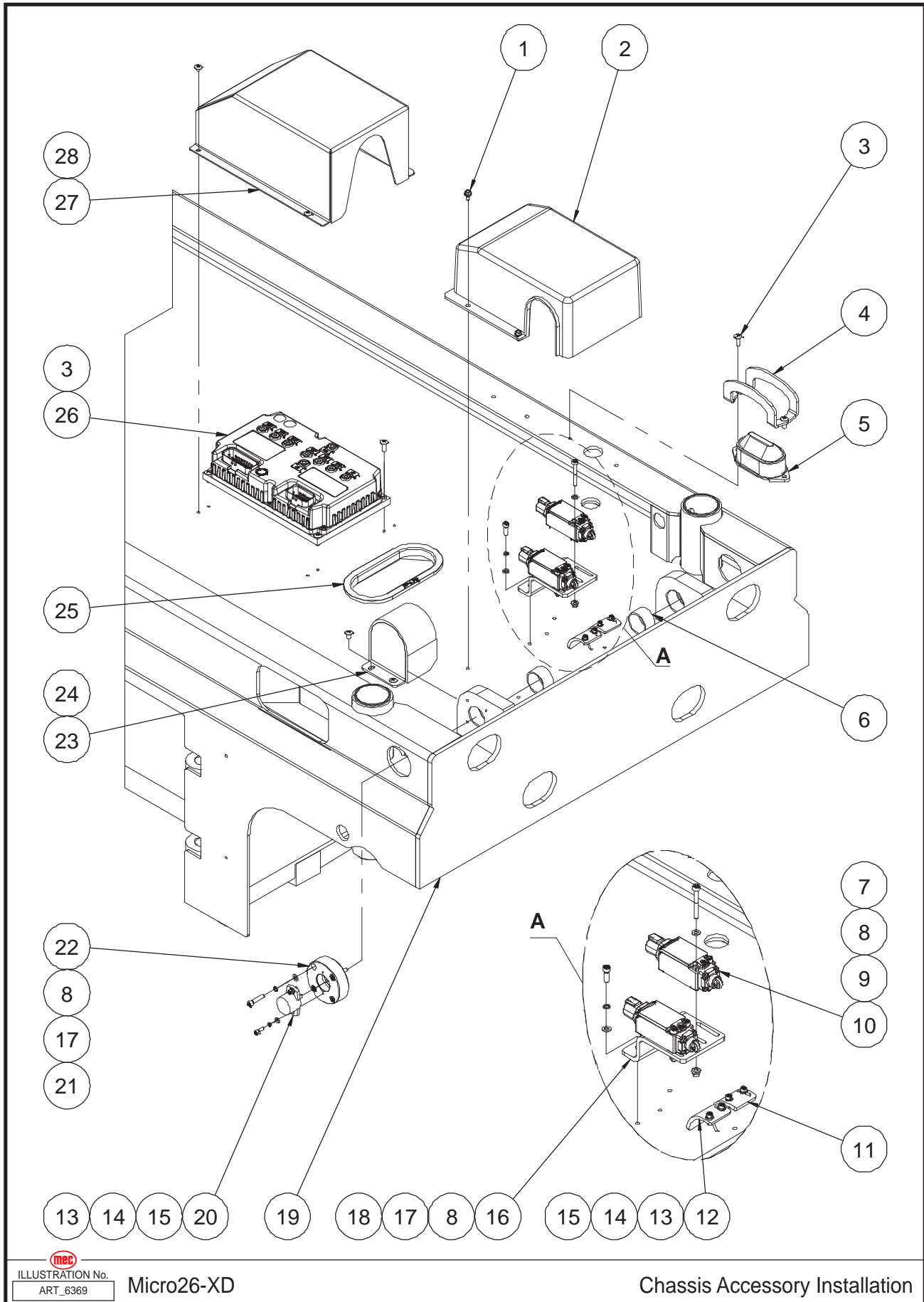
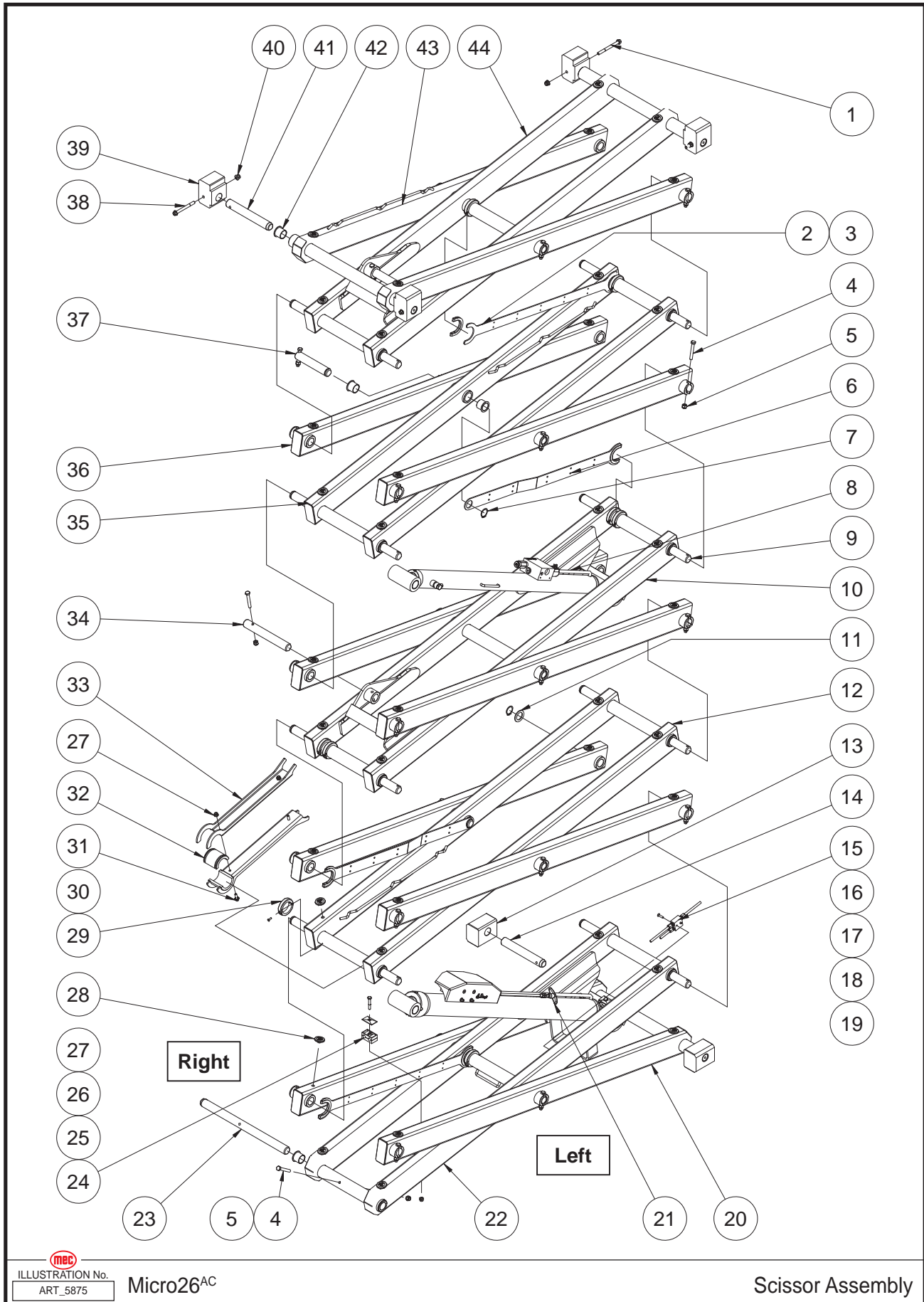



 ILLUSTRATION No. **Micro26-XD**
ART_6369

Chassis Accessory Installation

Item	Part Number	Description	Qty.
1	53449	Screw HHCS M05-0.80 x 10 Flange ZP	4
2	44895	Cover	1
3	53223	Screw THMS M05-0.80 x 16 ZP	6
4	41309	Beacon Cover	1
5	46264	Beacon	1
6	41051	Bearing	2
7	53067	Screw SHCS M05-0.80 x 40 ZP	4
8	53038	WSHR M05 Standard Flat Washer ZP	10
9	53281	Nut NNYL M05-0.80 Flange ZP	4
10	46265	Limit Switch	2
11	49201	Signal Plate 2	1
12	49141	Signal Plate 1	1
13	50423	Screw SHCS M04-0.70 x 12 ZP	6
14	53062	WSHR M04 Spring Washer ZP	6
15	50284	WSHR M04 Standard Flat Washer ZP	6
16	43593	Switch Bracket	1
17	53043	WSHR M05 Spring Washer ZP	6
18	50359	Screw SHCS M05-0.80 x 16 ZP	2
19	49202	Frame Weldment	1
20	46267	Rotary Sensor	1
21	53356	Screw SHCS M05-0.80 x 25 ZP	4
22	46268	Sensor Bracket	1
23	49203	Sensor Cover	1
24	53265	Screw THMS M05-0.80 x 10 ZP	2
25	46270	Sheath 2	1
26	46271	Motor Controller	1
27	49146	Cover	1
28	53266	Screw THMS M05-0.80 x 6 ZP	4

Scissor Assembly



 ILLUSTRATION No. **Micro26^{AC}**
ART_5875

Scissor Assembly

Item	Part Number	Description	Qty.
1	53267	Screw HHCS M10-1.50 x 110 Flange ZP	2
2	43595	Cable Bridge	2
3	44533	Clamp	6
4	50022	Screw HHCS M10-1.50 x 70 ZP	22
5	50049	Nut NNYL M10-1.50 ZP	22
6	43596	Cable Bridge	2
7	48859	Circlips	15
8	REF	Upper Lift Cylinder Assembly (Refer to page 92)	1
9	41686	Pin	11
10	49204	Inner Arm 3	1
11	41688	Washer	13
12	43599	Inner Arm 2	1
13	41710	Chassis Slider	2
14	41692	Pin	2
15	41112	Hydraulic Hoses Manifolds	1
16	50386	Screw CSCS M06-1.00 x 25 ZP	2
17	43600	Hose (To Lower Lift Cylinder)	1
18	43601	Hose (To Hydraulic Tank)	1
19	46274	Hose (To Upper Lift Cylinder)	1
20	43602	Outer Arm 1	1
21	REF	Lower Lift Cylinder Assembly (Refer to page 90)	1
22	49205	Inner Arm 1	1
23	46276	Pin	1
24	46277	Clamp	2
25	50015	Screw HHCS M08-1.25 x 50 ZP	2
26	41415	Clamp Plate	2
27	50313	Nut NNYL M08-1.25 Flange ZP	4
28	41114	Block	40
29	44884	Collar	8
30	53269	Screw CSCS M05-0.80 x 16 ZP	8
31	53270	Screw HHCS M08-1.25 x 25 Serrated Flange ZP	2
32	41616	Safety Arm Bushing	2
33	41615	Safety Arm	2
34	41687	Pin	4
35	43605	Inner Arm 4	1
36	43606	Outer Arm 2	3
--	46278	Left Single Link	1
--	46279	Right Single Link	1
37	41689	Pin	4
38	53271	Screw HHCS M10-1.50 x 100 Flange ZP	2
39	43607	Platform Slider	4
40	50311	Nut NNYL M10-1.50 Flange ZP	4
41	41685	Pin	4
42	41706	Bearing	36

43	43608	Outer Arm 4	1
44	49206	Inner Arm 5	1

REF - Reference

THIS PAGE HAS BEEN INTENTIONALLY LEFT BLANK

Main Platform Assembly

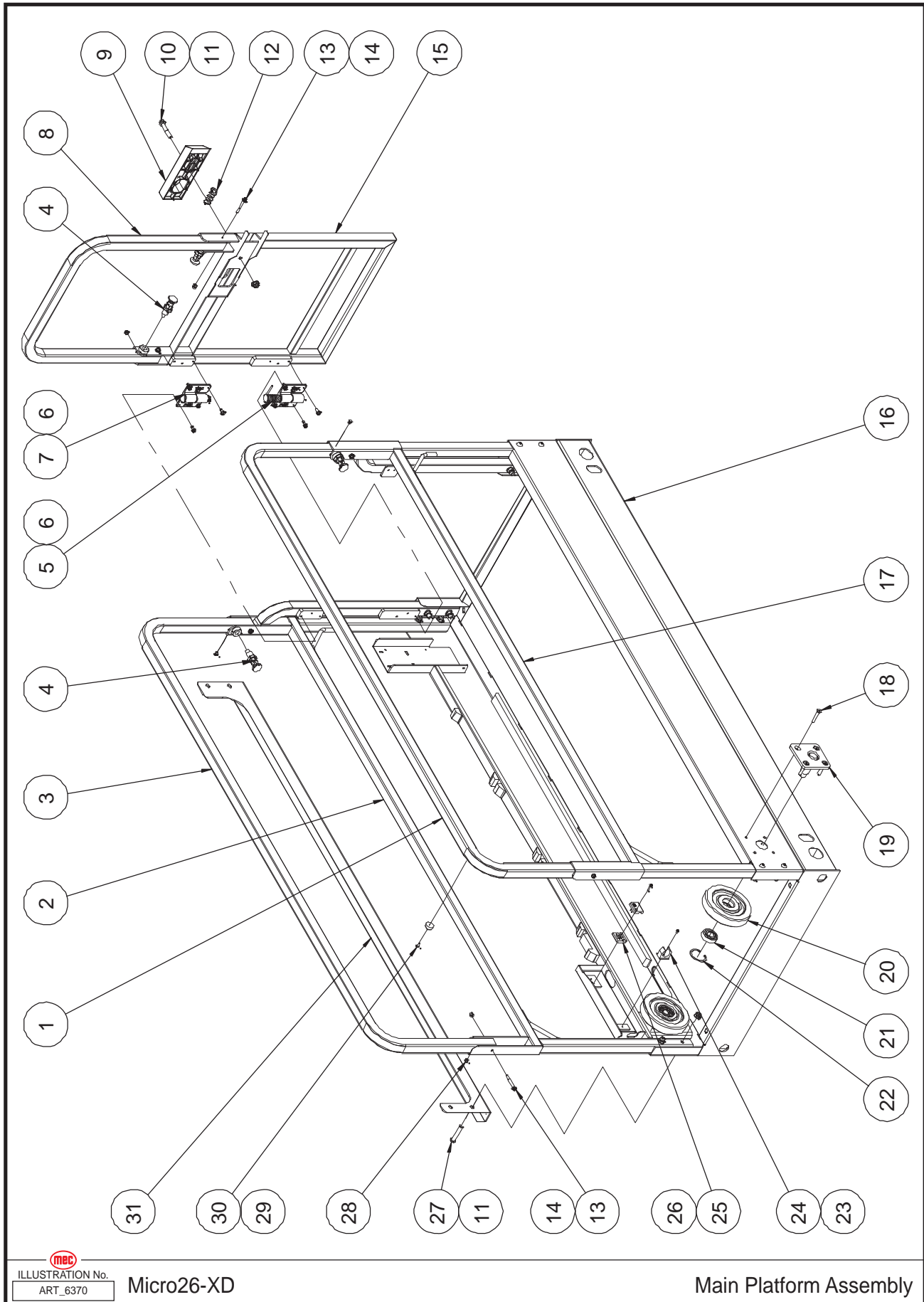

 ILLUSTRATION No. ART_6370 Micro26-XD

Main Platform Assembly

Item	Part Number	Description	Qty.
1	46280	Upper Main Rail, Left	1
2	46281	Lower Main Rail, Right	1
3	46282	Upper Main Rail, Right	1
4	43337	Lock Pin	4
5	41128	Hinge B	1
6	53273	Screw HHCS M06-1.00 x 14 Serrated Flange ZP	12
7	41127	Hinge A	1
8	43613	Door Rail	1
9	41124	Latch Handle	1
10	53272	Screw HHCS M10-1.50 x 55 Flange ZP	1
11	50311	Nut NNYL M10-1.50 Flange ZP	13
12	41125	Spring	1
13	53274	Screw HHCS M06-1.00 x 50 Flange ZP	6
14	50568	Nut NNYL M06-1.00 Flange ZP	6
15	43614	Entry Gate	1
16	46283	Main Deck Weldment	1
17	46284	Lower Main Rail, Left	1
18	53275	Screw CSCS M08-1.25 x 45 ZP	8
19	41270	Roller Bracket	2
20	43617	Roller	2
21	41131	Bearing	2
22	43618	Circlips	2
23	53276	Screw PHMS M04-0.70 x 8 ZP	1
24	41134	Clip	1
25	41059	Wire Clip	2
26	53278	Screw SHCS M04-0.70 x 20 ZP	2
27	53277	Screw BHCS M10-1.50 x 55 ZP	12
28	45339	Hole Plug	6
29	41120	Bumper	1
30	53224	Screw THMS M05-0.80 x 12 ZP	1
31	48387	Sheet Material Tray	1

Xtra Deck® Platform Extension Assembly

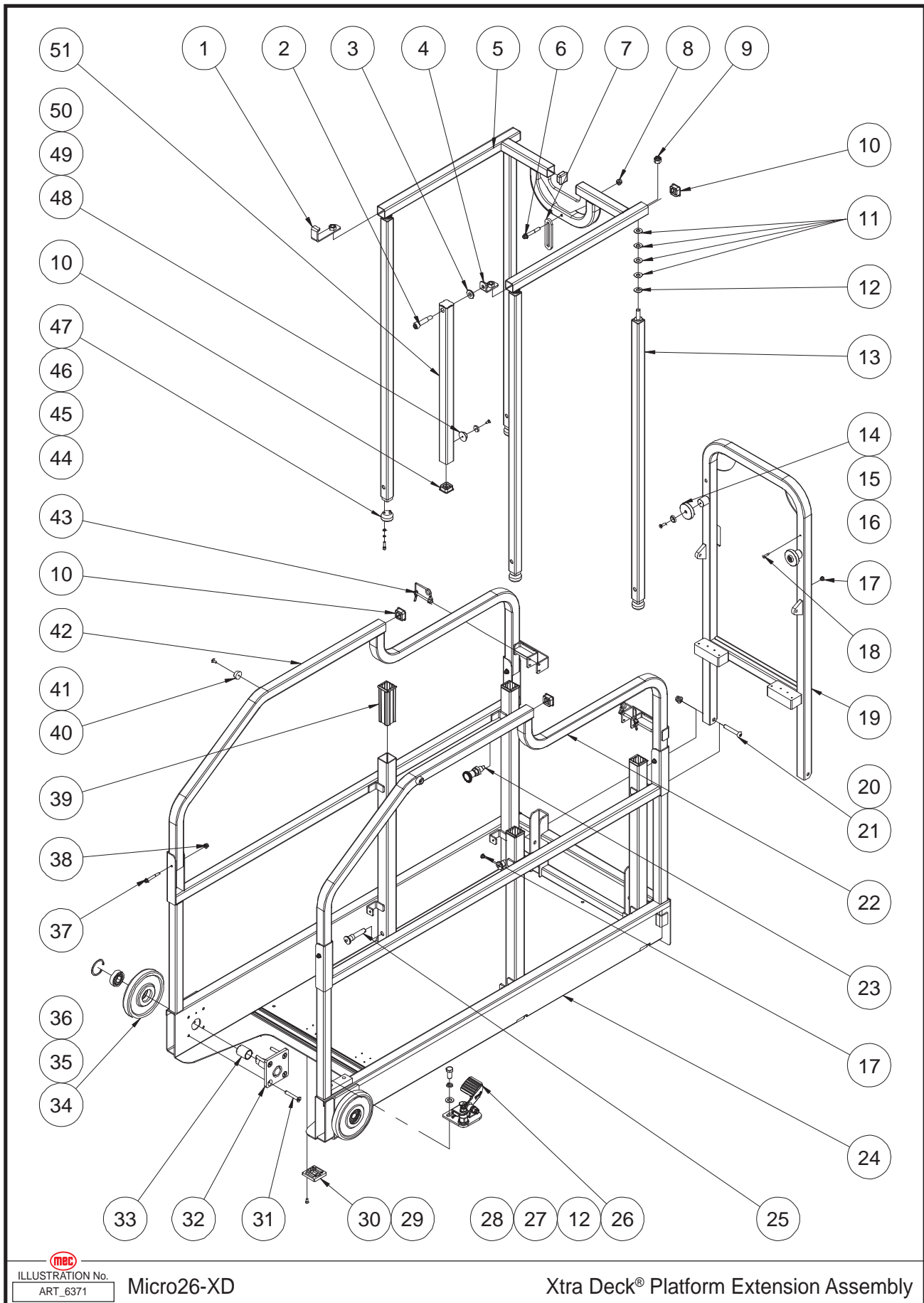

 ILLUSTRATION No. **Micro26-XD**
ART_6371

Xtra Deck® Platform Extension Assembly

Item	Part Number	Description	Qty.
1	44227	Deck Guard Latch Rest Weldment	1
2	49223	Pin	1
3	44823	Washer	1
4	44237	Deck Guard Hinge Weldment	1
5	49224	Upper Extension Rail	1
6	53359	Screw HHCS M08-1.25 x 55 Flange ZP	1
7	44223	Baffle Plate	1
8	50313	Nut NNYL M08-1.25 Flange ZP	1
9	50050	Nut NNYL M12-1.75 ZP	2
10	49209	Plug	7
11	49210	Disc Spring	16
12	50003	WSHR M12 Standard Flat Washer ZP	6
13	49211	Telescopic Rail	4
14	49212	Magnet	2
15	49213	Washer	2
16	50561	Screw CSCS M06-1.00 x 20 ZP	2
17	45339	Hole Plug	4
18	43301	Rivet	2
19	49214	Front Rail	1
20	50311	Nut NNYL M10-1.50 Flange ZP	2
21	53295	Screw BHCS M10-1.50 x 60 ZP	2
22	49215	Right Extension Rail	1
23	44016	Lock Pin	4
24	49216	Extension Deck Weldment	1
25	49217	Inserted Pin	4
26	44599	Platform Locking Device Assembly (Refer to page 84)	1
27	53148	WSHR M12 Spring Washer ZP	2
28	50038	Screw HHCS M12-1.75 x 25 ZP	2
29	53279	Screw CSCS M05-0.80 x 12 ZP	8
30	41284	Slide Pad	2
31	53280	Screw CSCS M08-1.25 x 55 ZP	8
32	41270	Roller Bracket	4
33	46393	Bearing	2
34	41141	Roller 2	2
35	41131	Bearing	4
36	43618	Circlips GB/T 893.1-47	4
37	53274	Screw HHCS M06-1.00 x 50 Flange ZP	4
38	50568	Nut NNYL M06-1.00 Flange ZP	4
39	49218	Upper Guide Sleeve	4
40	41120	Bumper	2
41	53224	Screw THMS M05-0.80 x 12 ZP	2
42	49219	Left Extension Rail	1
43	41357	Inserted Pin	2
44	53150	Screw SHCS M05-0.80 x 20 ZP	8

45	53043	WSHR M05 Spring Washer ZP	8
46	53038	WSHR M05 Standard Flat Washer ZP	8
47	49220	Bottom Guide Block	4
48	44239	Sheath	1
49	49221	Magnet 2	1
50	53279	Screw CSCS M05-0.80 x 12 ZP	1
51	49222	Rear Extension Rail	1

THIS PAGE HAS BEEN INTENTIONALLY LEFT BLANK

Xtra Deck® Step Installation

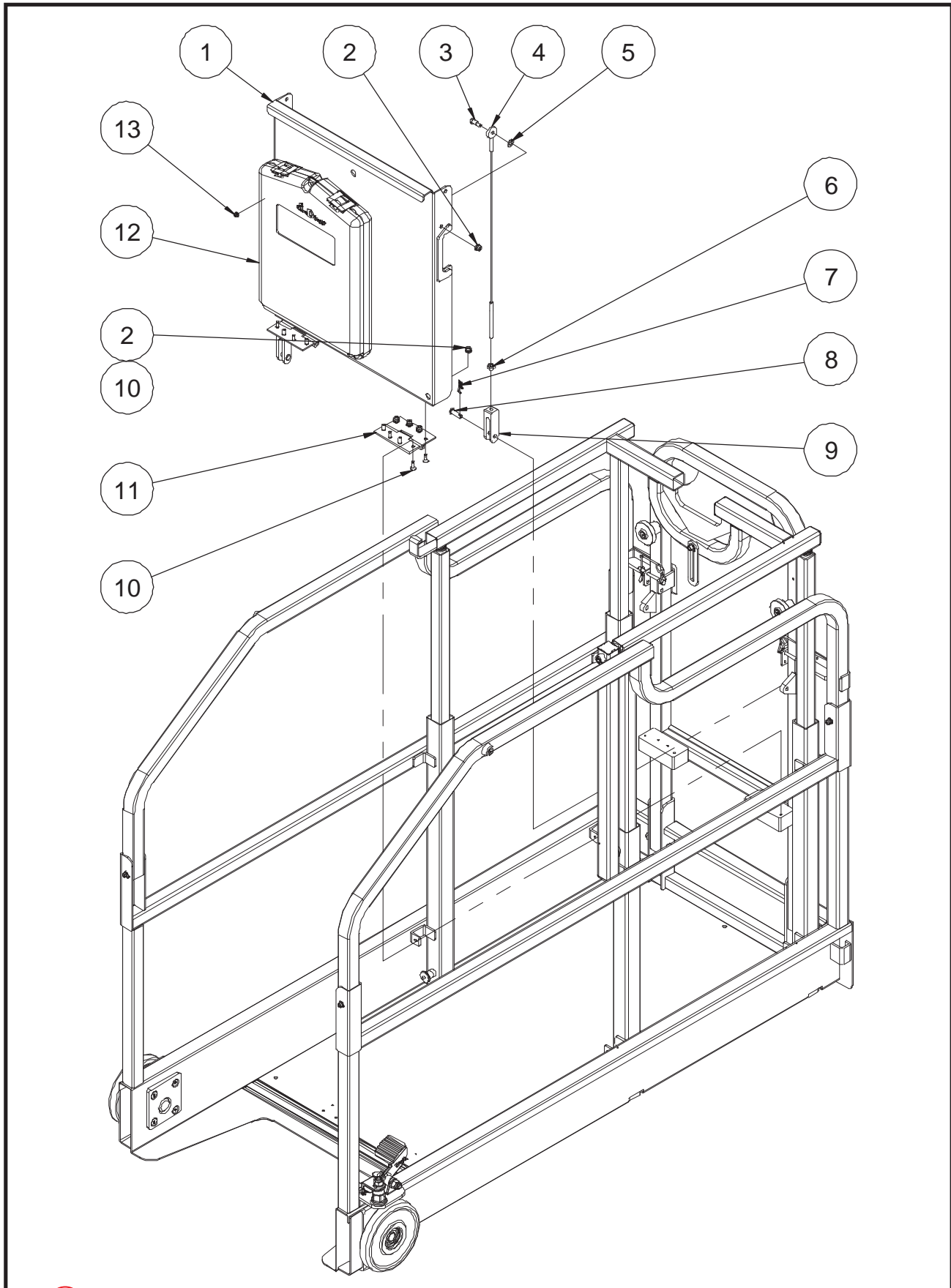

 ILLUSTRATION No. **Micro26-XD**
ART_6372

Xtra Deck® Step Installation

Item	Part Number	Description	Qty.
1	49225	Xtra Step Weldment	1
2	50568	Nut NNYL M06-1.00 Flange ZP	18
3	46772	Pin	2
4	46771	Wire Rope	2
5	50001	WSHR M08 Standard Flat Washer ZP	2
6	53014	Nut NHEX M08-1.25 ZP	2
7	46541	Cotter Pin	2
8	49226	Pin	2
9	49227	Adjustment Joint	2
10	53226	Screw CSCS M06-1.00 x 16 ZP	16
11	49228	Hinge	2
12	43319	Manual Box	1
13	53281	Nut NNYL M05-0.80 Flange ZP	4

Platform Locking Device Assembly

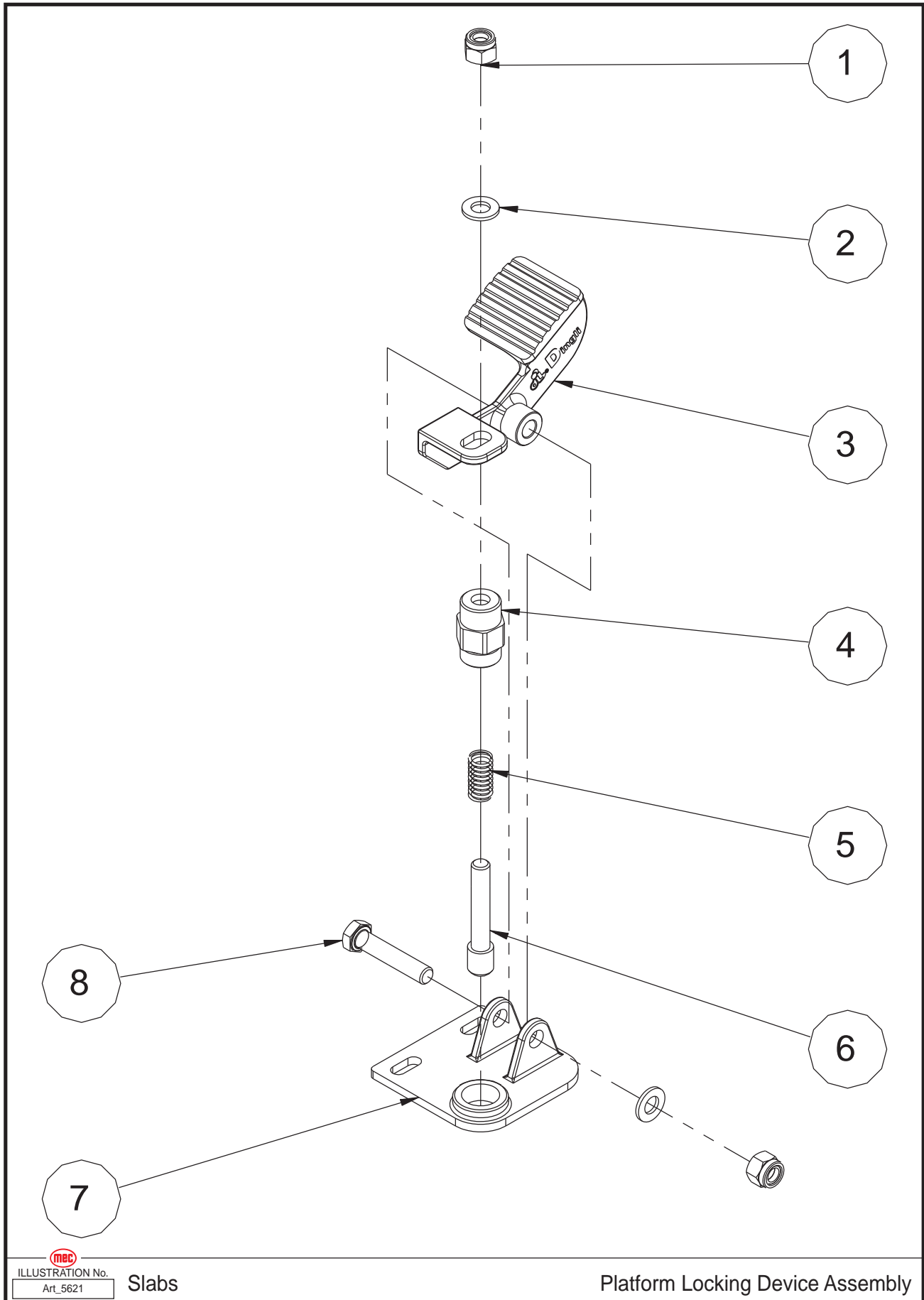

 ILLUSTRATION No. Slabs
Art_5621

Platform Locking Device Assembly

Item	Part Number	Description	Qty.
1	50049	Nut NNYL M10-1.50 ZP	2
2	50002	WSHR M10 Standard Flat Washer ZP	2
3	41143	Foot Pedal	1
4	41144	Lock Pin Housing	1
5	41145	Spring	1
6	41146	Lock Pin	1
7	44767	Bracket	1
8	50020	Screw HHCS M10-1.50 x 50 ZP	1

Platform Control Assembly

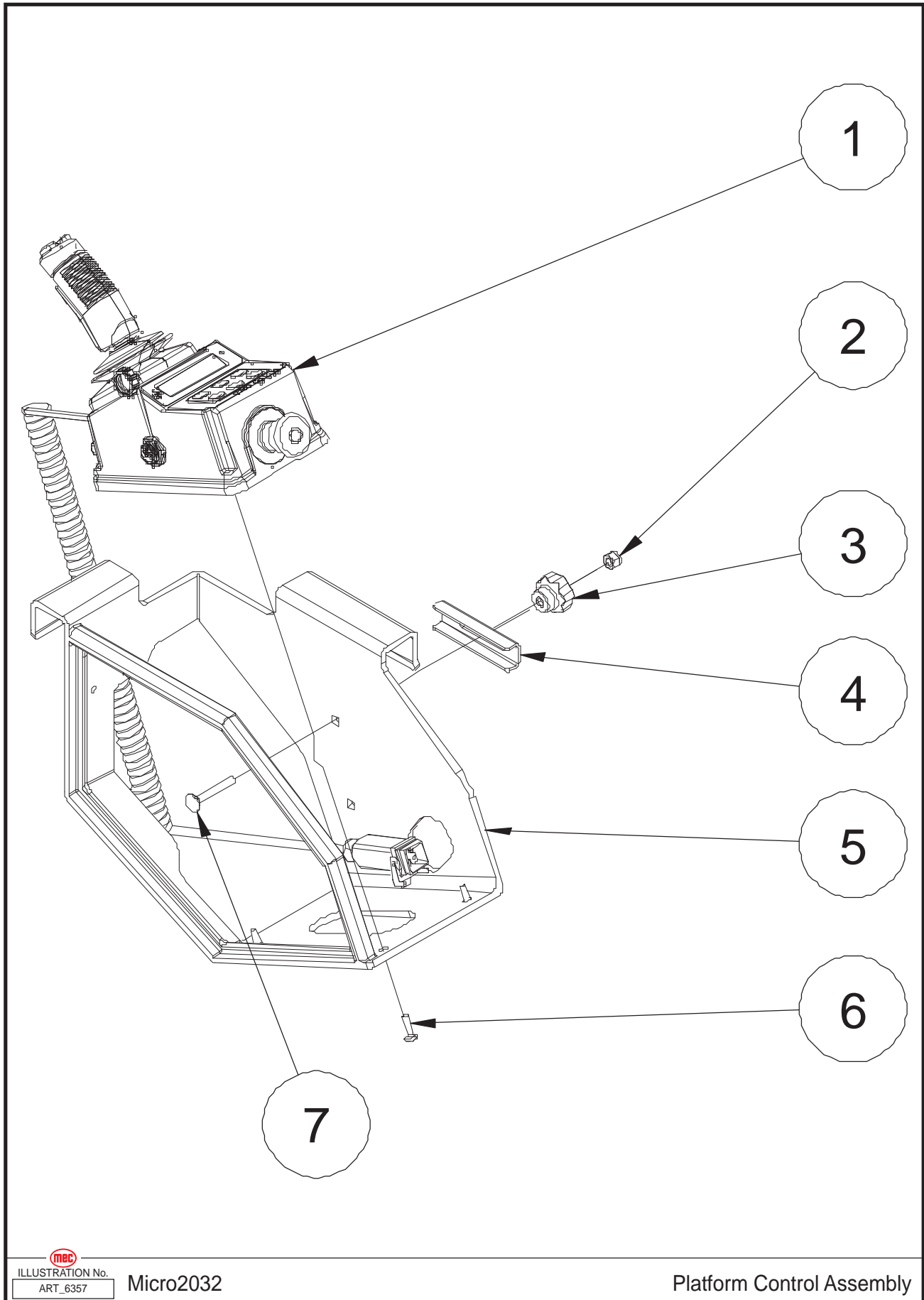

 ILLUSTRATION No. **Micro2032**
ART_6357

Platform Control Assembly

Item	Part Number	Description	Qty.
1	46315	Platform Control Box Assembly (Refer to page 88)	1
2	50048	Nut NNYL M08-1.25 ZP	1
3	42501	Handle	1
4	42500	Locating Plate	1
5	42499	Platform Control Box Mount Bracket (To SN 19900732)	1
	49023	Platform Control Box Mount Bracket (From SN 19900733-19901099)(From SN 19901229)	1
6	53264	Screw PHMS M06-1.00 x 20 ZP	4
7	53610	Screw CARB M08-1.25 x 50 ZP	1

Platform Control Box Assembly

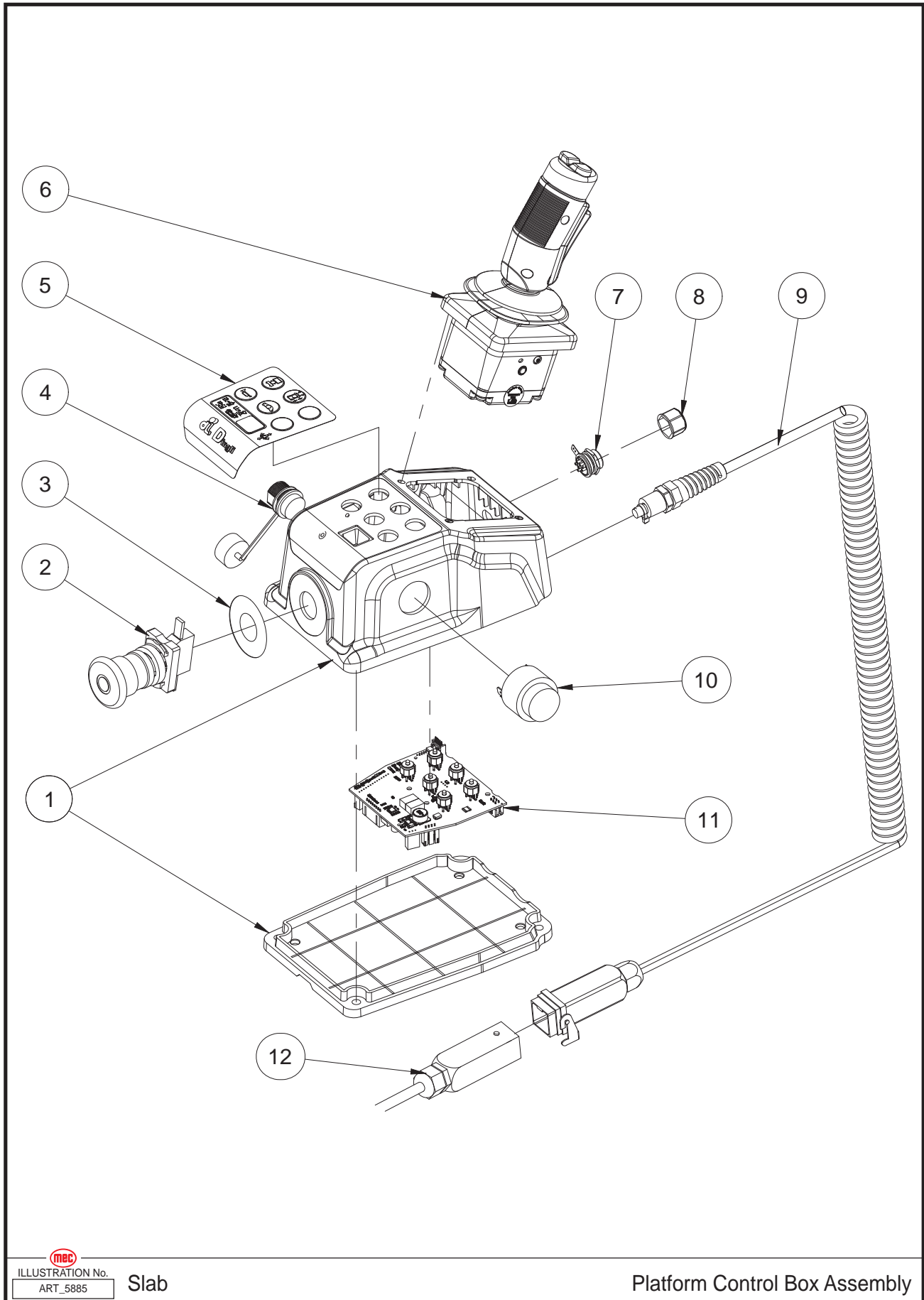
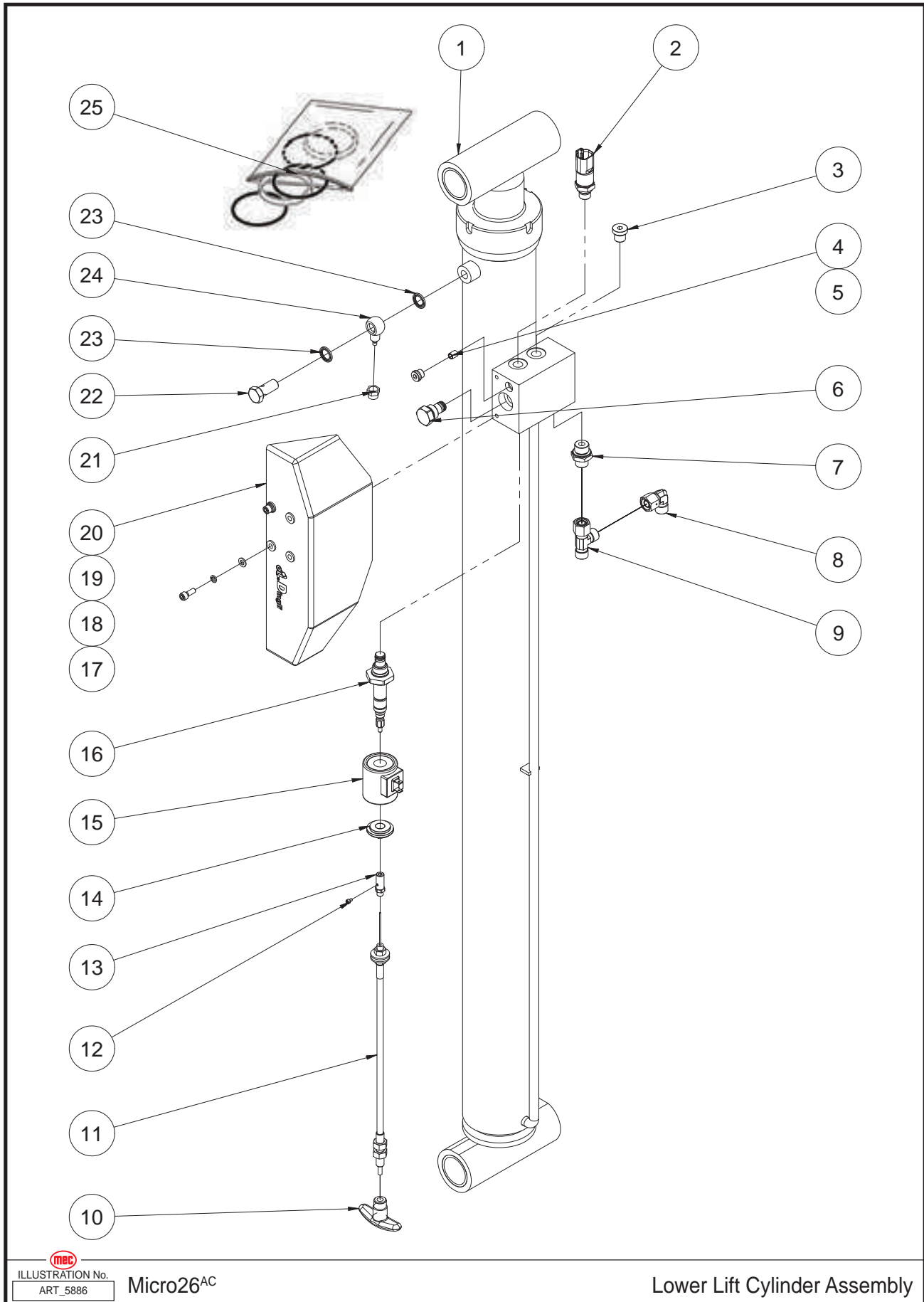



 ILLUSTRATION No. ART_5885 Slab

Platform Control Box Assembly

Item	Part Number	Description	Qty.
1	44768	Shell Components	1
2	41157	Emergency Stop Switch	1
--	43632	Red Mushroom Head	1
--	43633	Base With 1 NO Contact	1
3	42915	Decal, Emergency Stop Panel	1
4	44769	USB Cable	1
5	44797	Decal, Platform Control Panel	1
6	46289	Joystick	1
--	43621	Function Enable Switch	1
--	46290	Joystick Cover	1
--	43622	Joystick Steer Switch	1
--	43623	Switch Boot	1
7	44770	Connector	1
8	44771	Connector Cap	1
9	44772	Coil Cord	1
--	44773	Hood	1
--	44774	Female Insert	1
--	44775	Female Contacts	5
--	43627	Cable Gland	1
10	41568	Alarm	1
--	43631	Alarm Nut	1
11	44776	PCU Main Board	1
12	46291	Platform Control Box Harness	1
--	44778	Housing	1
--	44779	Male Insert	1
--	44780	Male Contacts	5
--	43627	Cable Gland	1

Lower Lift Cylinder Assembly



 ILLUSTRATION No. **Micro26^{AC}**
ART_5886

Lower Lift Cylinder Assembly

Item	Part Number	Description	Qty.
1	43636	Lower Lift Cylinder	1
2	44448	Pressure Sensor	1
3	42480	Plug	1
4	43637	Orifice	1
5	42821	Plug	1
6	49167	Check Valve	1
7	43638	Straight Fitting	1
8	43639	Elbow	1
9	43640	Tee Fitting	1
10	43367	Lowering Knob	1
11	49168	Emergency Down Cable Assembly	1
12	50423	Screw SHCS M04-0.70 x 12 ZP	1
13	43365	Cable Connector	1
14	53362	Nut NHEX 1/2-20 UNF	1
15	46764	Coil	1
16	45385	Solenoid Valve Spool	1
17	53138	Screw SHCS M06-1.00 x 16 ZP	2
18	53046	WSHR M06 Spring Washer ZP	2
19	50000	WSHR M06 Standard Flat Washer ZP	2
20	41164	Valve Cover	1
21	41413	Nut	1
22	41166	Fitting	1
23	43361	Washer	2
24	41167	Fitting	1
25	41630	Seal Kit	1

Upper Lift Cylinder Assembly

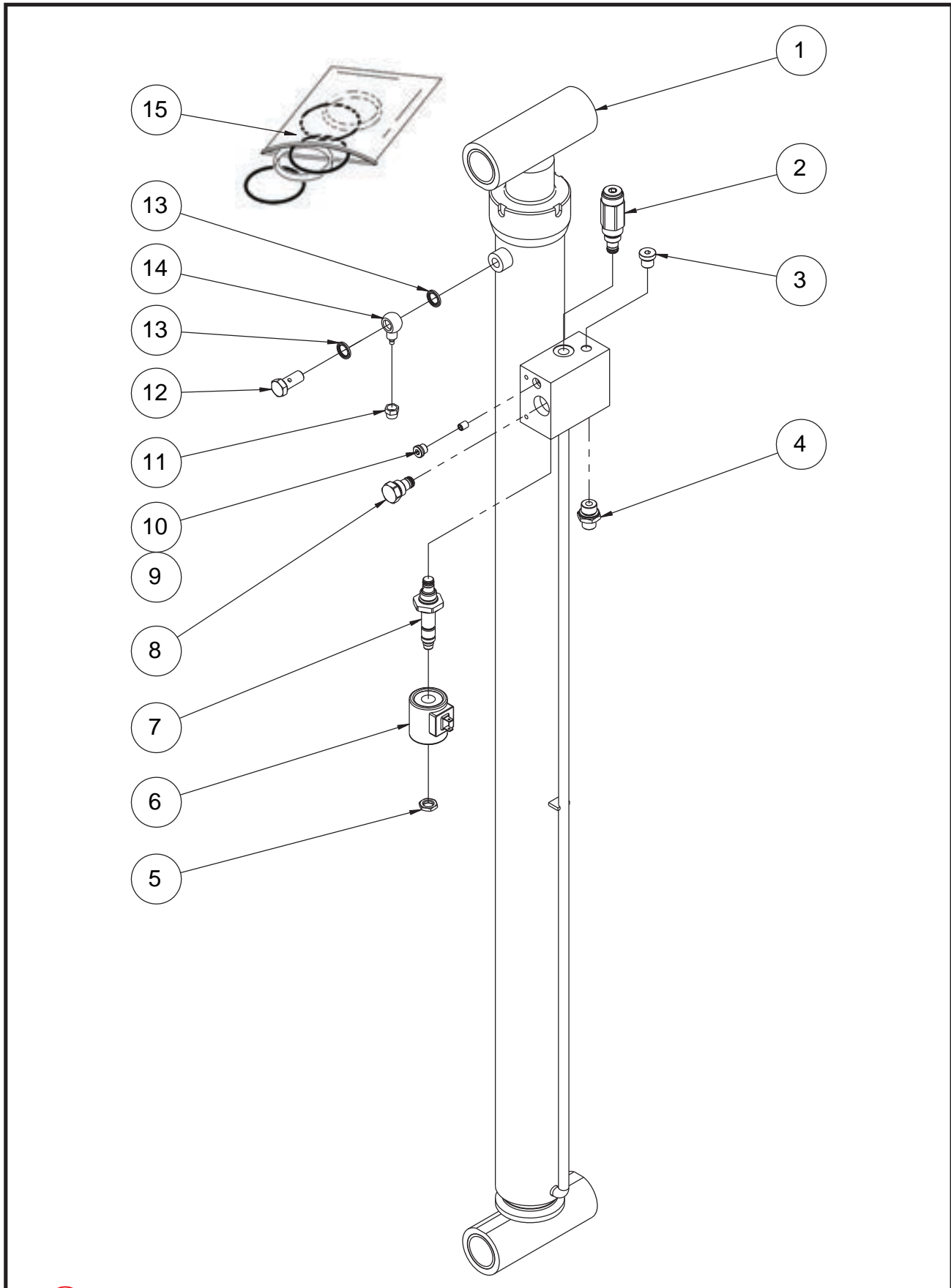

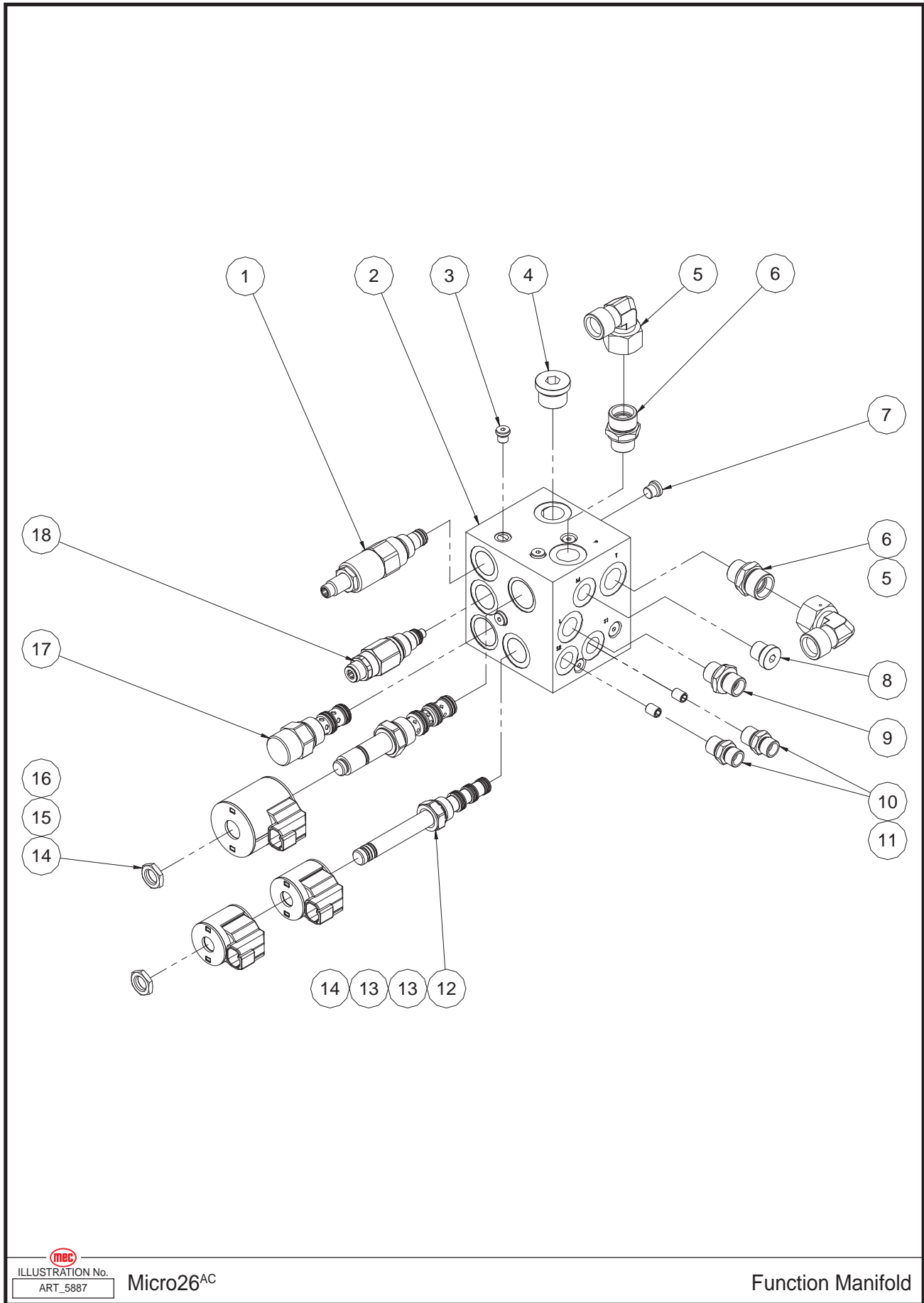

ILLUSTRATION No.
Art_5482

Micro26

Upper Lift Cylinder Assembly

Item	Part Number	Description	Qty.
1	43641	Upper Lift Cylinder	1
2	41169	Relief Valve	1
3	42480	Plug	1
4	43638	Straight Fitting	1
5	53362	Nut NHEX 1/2-20 UNF	1
6	46764	Coil	1
7	45390	Solenoid Valve Spool	1
8	49167	Check Valve	1
9	43374	Orifice	1
10	42821	Plug	1
11	41413	Nut	1
12	41166	Fitting	1
13	43361	Washer	2
14	41167	Fitting	1
15	43642	Seal Kit	1

Function Manifold

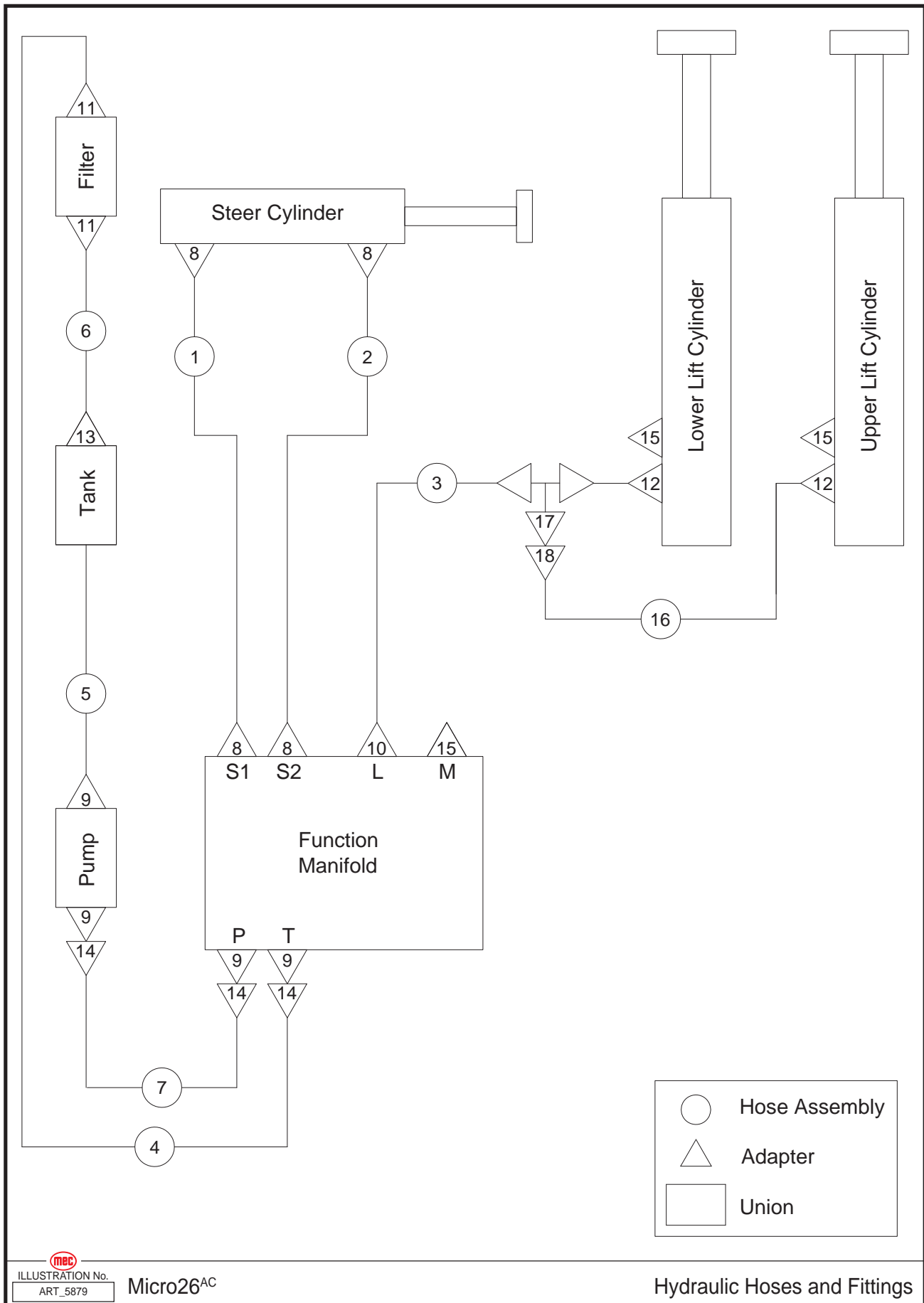



 ILLUSTRATION No. **Micro26^{AC}**
ART_5887

Function Manifold

Item	Part Number	Description	Qty.
1	46292	Relief Valve (RV1)	1
2	46293	Valve Body	1
3	43465	Plug	13
4	43079	Plug	1
5	43206	Elbow	2
6	43582	Straight Fitting	2
7	43643	Plug	3
8	42480	Plug	1
9	43644	Straight Fitting	1
10	43076	Straight Fitting	2
11	43645	Orifice	2
12	41537	Solenoid Valve Spool (SV1)	1
13	46294	Coil	2
14	42795	Nut	2
15	46295	Coil	1
16	41548	Solenoid Valve Spool (SV2)	1
17	46296	Flow Control Valve (FR1)	1
18	46297	Relief Valve (RV2)	1

Hydraulic Hoses and Fittings



 ILLUSTRATION No. **Micro26^{AC}**
ART_5879

Hydraulic Hoses and Fittings

Item	Part Number	Description	Qty.
1	41839	Hose Assembly, S1 Steer Hose	1
2	43709	Hose Assembly, S2 Speed Hose	1
3	44915	Hose Assembly	1
4	46298	Hose Assembly, Return Hose	1
5	46299	Hose Assembly, Suction Hose	1
6	46300	Hose Assembly, Filter to Tank Hose	1
7	49169	Hose Assembly, Main Pump Hose	1
8	43076	Straight Fitting	4
9	43582	Straight Fitting	4
10	43644	Straight Fitting	1
11	43576	Straight Fitting	2
12	43638	Straight Fitting	2
13	41085	Fitting	1
14	43206	Elbow	4
15	42480	Plug	3
16	44249	Hose Assembly	1
17	43640	Tee Fitting	1
18	43639	Elbow	1

Electrical Harness

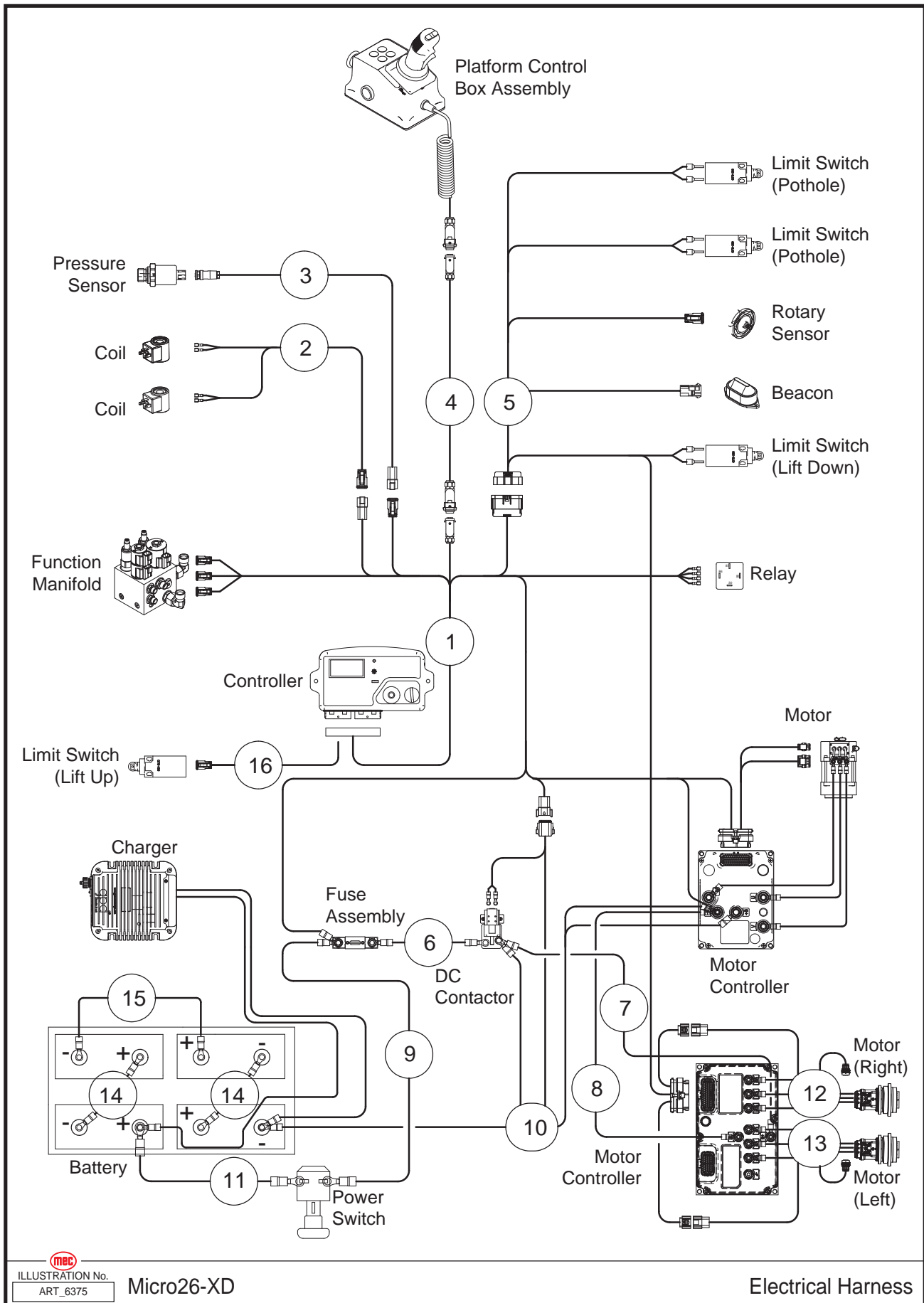
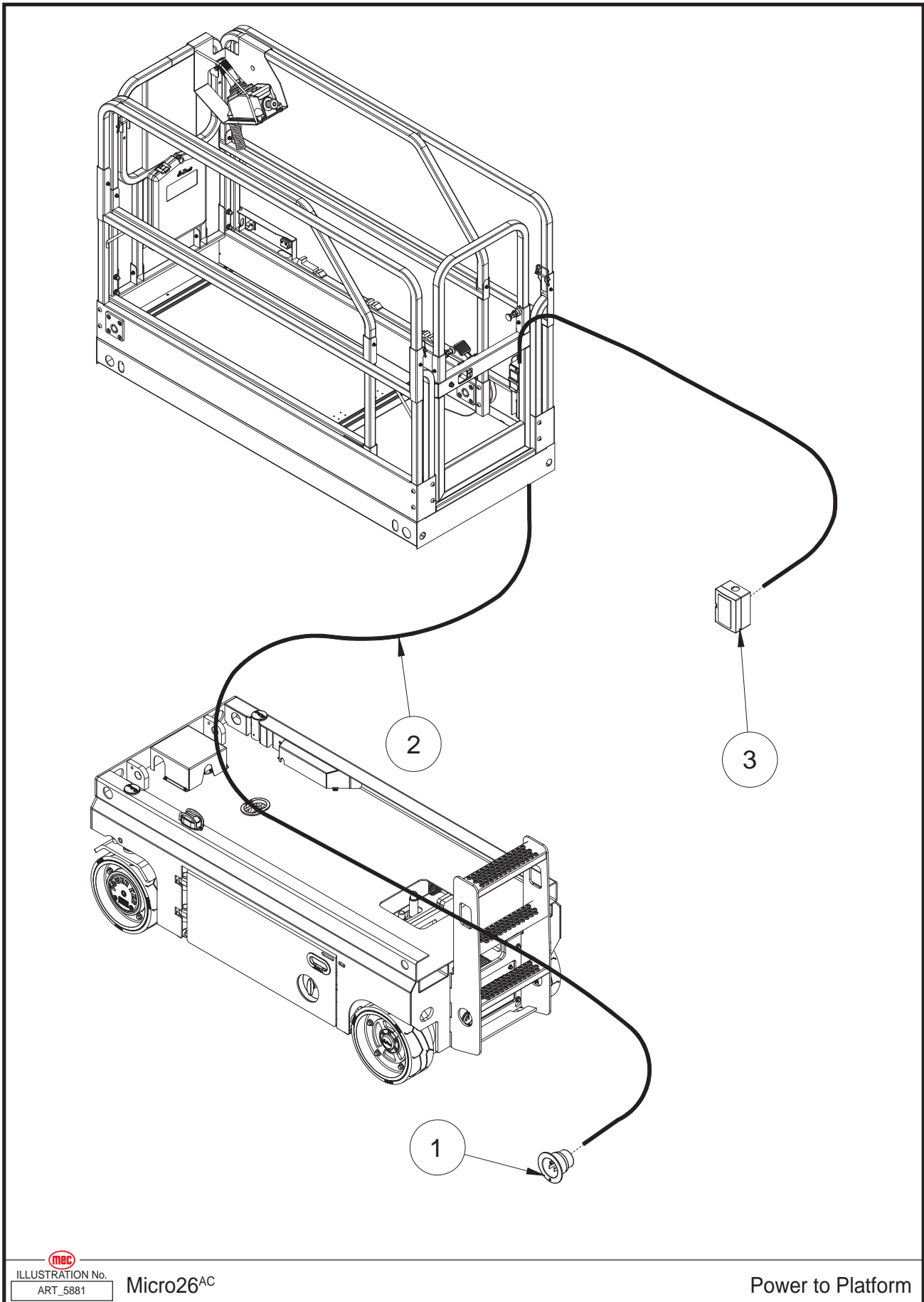



 ILLUSTRATION No. **Micro26-XD**
ART_6375

Electrical Harness

Item	Part Number	Description	Qty.
1	46302	ECU Harness	1
2	46303	Lowering Valve Harness	1
3	46304	Pressure Sensor Harness	1
4	46291	Platform Control Box Harness	1
5	46305	Limit Switch and Drive Motor Harness	1
6	46306	Power Harness	1
7	46307	Power Harness	1
8	46308	Power Harness	1
9	46309	Power Harness	1
10	46310	Power Harness	1
11	46311	Power Harness	1
12	47482	Drive Motor Harness, Right	1
13	47489	Drive Motor Harness, Left	1
14	45411	Battery Harness	2
15	45412	Battery Harness	1
16	49171	Outdoor Limit Up Switch Harness	1

Power to Platform



 ILLUSTRATION No. ART_5881 **Micro26^{AC}**

Power to Platform

Item	Part Number	Description	Qty.
1	REF	AC Plug (Refer to page 68)	1
2	43721	Wire Cable, Platform AC Power	1
3	42613	AC Socket	1

REF - Reference

Decals

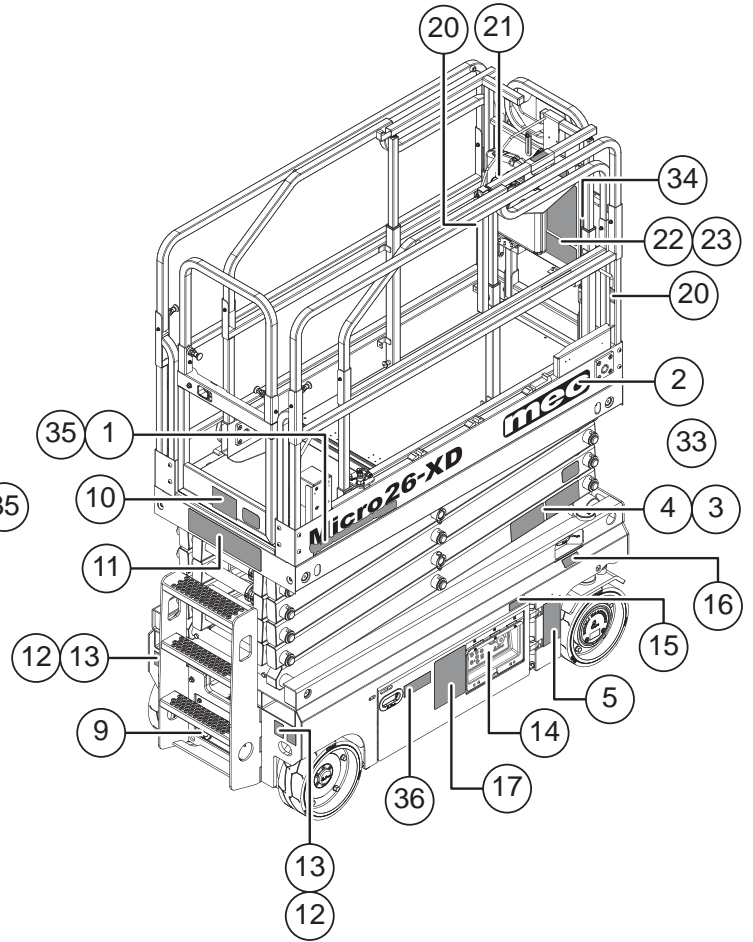
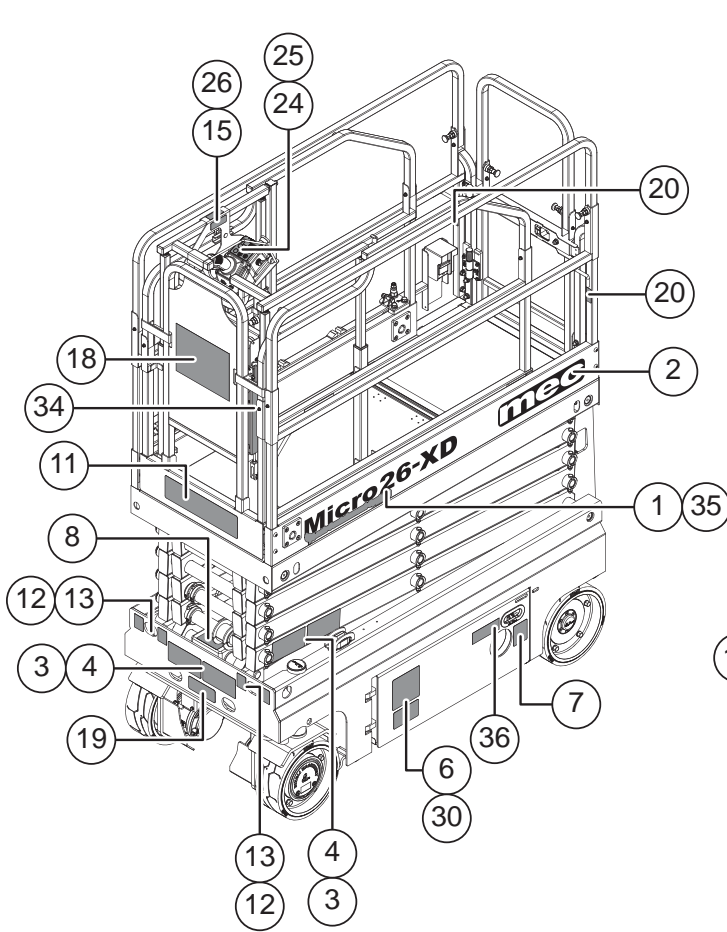



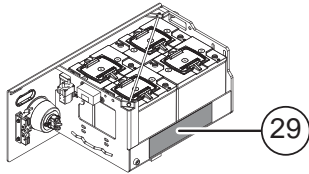



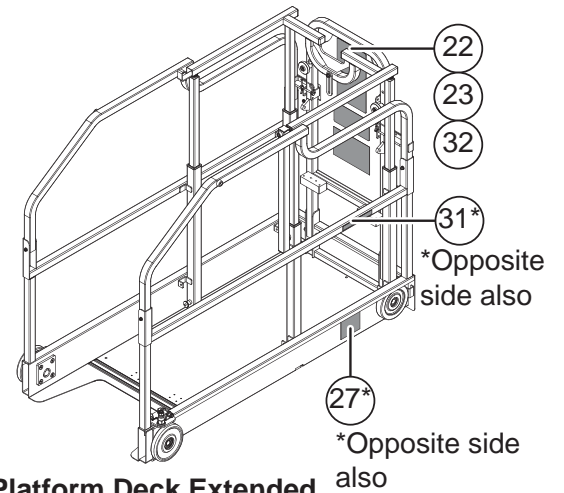
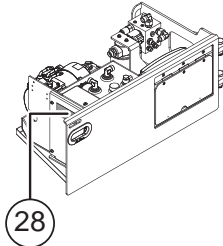



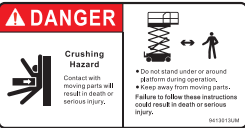



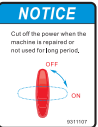
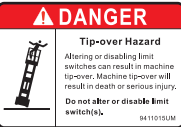



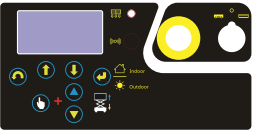
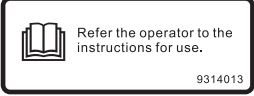



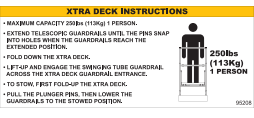

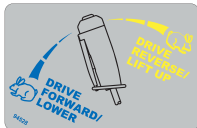

Battery Modue

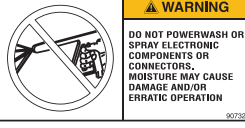

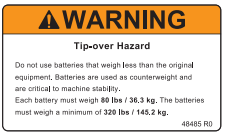
Control Modue



**Platform Deck Extended
Xtra Deck® Remove**

<p>1</p> <p>Micro26-XD</p> <p>47839 Qty. - 2</p>	<p>2</p>  <p>94114 Qty. - 2</p>	<p>3</p>  <p>41646 Qty. - 3</p>	<p>4</p>  <p>41748 Qty. - 3</p>	<p>5</p>  <p>95215 Qty. - 1</p>
<p>6</p>  <p>41641 Qty. - 1</p>	<p>7</p>  <p>41666 Qty. - 1</p>	<p>8</p>  <p>41642 Qty. - 1</p>	<p>9</p> <p>BATTERY CHARGER AND POWER TO PLATFORM</p> <p>94659 Qty. - 1</p>	<p>10</p>  <p>95301 Qty. - 1</p>
<p>11</p>  <p>47535 Qty. - 2</p>	<p>12</p>  <p>41635 Qty. - 4</p>	<p>13</p>  <p>41634 Qty. - 4</p>	<p>14</p>  <p>44795 Qty. - 1</p>	<p>15</p>  <p>41639 Qty. - 2</p>
<p>16</p> <p>EMERGENCY LOWER</p> <p>Pull knob to lower platform</p> <p>9311017</p> <p>41636 Qty. - 1</p>	<p>17</p>  <p>41649 Qty. - 1</p>	<p>18</p>  <p>90719 Qty. - 1</p>	<p>19</p>  <p>94423 Qty. - 1</p>	<p>20</p>  <p>41648 Qty. - 4</p>
<p>21</p> <p>XTRA DECK INSTRUCTIONS</p>  <p>95208 Qty. - 1</p>	<p>22</p>  <p>43885 Qty. - 2</p>	<p>23</p>  <p>41647 Qty. - 2</p>	<p>24</p>  <p>94528 Qty. - 1</p>	<p>25</p>  <p>44797 Qty. - 1</p>
<p>26</p>  <p>41640 Qty. - 1</p>	<p>27</p>  <p>91850 Qty. - 2</p>	<p>28</p>  <p>90732 Qty. - 1</p>	<p>29</p>  <p>43879 Qty. - 1</p>	<p>30</p>  <p>48485 Qty. - 1</p>
<p>31</p> <p>PATENT PENDING</p> <p>94865 Qty. - 2</p>	<p>32</p>  <p>95389 Qty. - 1</p>	<p>33</p>  <p>96494 Qty. - 2</p>	<p>34</p>  <p>95188 Qty. - 2</p>	<p>35</p>  <p>94866 Qty. - 2</p>
<p>36</p>  <p>94867 Qty. - 2</p>				

Notes

Notes



Limited Owner Warranty

MEC Aerial Platform Sales Corp. warrants its equipment to the original purchaser against defects in material and/or workmanship under normal use and service for one (1) year from date of registered sale or date the unit left the factory if not registered. MEC Aerial Platform Sales Corp. further warrants the structural weldments of the main frame and scissor arms to be free from defects in material or workmanship for five (5) years from date of registered sale or date unit left the factory if not registered. Excluded from such warranty is the battery(s) which carries a ninety (90) day warranty from described purchase date. Warranty claims within such warranty period shall be limited to repair or replacement, MEC Aerial Platform Sales Corp's option, of the defective part in question and labor to perform the necessary repair or replacement based on MEC Aerial Platform Sales Corp's then current flat rate, provided the defective part in question is shipped prepaid to MEC Aerial Platform Sales Corp. and is found upon inspection by MEC Aerial Platform Sales Corp. to be defective in material and/or workmanship. MEC Aerial Platform Sales Corp. shall not be liable for any consequential, incidental or contingent damages whatsoever. Use of other than factory authorized parts; misuse, improper maintenance, or modification of the equipment voids this warranty. The foregoing warranty is exclusive and in lieu of all other warranties, express or implied. All such other warranties, including implied warranties of merchantability and of fitness for a particular purpose, are hereby excluded. No Dealer, Sales Representative, or other person purporting to act on behalf of MEC Aerial Platform Sales Corp. is authorized to alter the terms of this warranty, or in any manner assume on behalf of MEC Aerial Platform Sales Corp. any liability or obligation which exceeds MEC Aerial Platform Sales Corp's obligations under this warranty.



MEC Aerial Work Platforms

1401 S. Madera Avenue, Kerman, CA 93630 USA
Toll Free: 1.877.MEC.LIFT or 1.877.632.5438
Phone: 1.559.710.2425
Fax: 1.559.710.2390
info@MECawp.com
www.MECawp.com