

# Operator's Manual

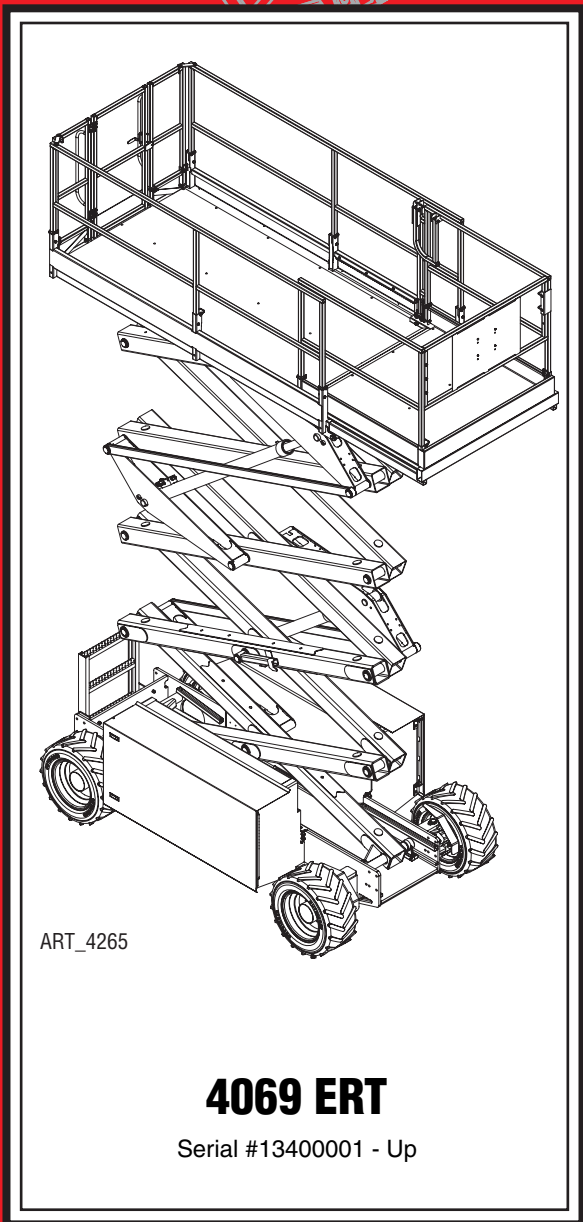

ART\_4265

## 4069 ERT

Serial #13400001 - Up

93072  
March 2013

<b>Specifications</b> .....	<b>inside cover</b>
<b>Introduction</b> .....	<b>1</b>
<b>Safety</b> .....	<b>2</b>
Safety Alert Symbols .....	2
Fall Protection .....	3
Electrocution Hazard .....	4
Tip-over Hazards .....	5
Fall Hazards .....	6
Collision Hazards .....	6
Additional Safety Hazards .....	7
Battery Safety .....	7
<b>Controls &amp; Components</b> .....	<b>8</b>
Platform Controls .....	8
Lower Controls .....	9
Component Locations .....	10
<b>Workplace Inspection</b> .....	<b>11</b>
<b>Operating Instructions &amp; Function Tests</b> .....	<b>12</b>
Prestart .....	12
Base Controls Operation and Test .....	13
Platform Control Operation and Test .....	14
Control Lever Operation .....	17
Shutdown Procedure .....	19
Deck Extension .....	19
Sheet Materials Rack .....	20
Outrigger Operation (optional) .....	23
Emergency Lowering System .....	23
Fold Down Platform Railings .....	24
<b>Battery Charger</b> .....	<b>25</b>
Charge Batteries .....	26
<b>Maintenance</b> .....	<b>27</b>
Routine Maintenance .....	28
Frequent and Annual Maintenance .....	28
Maintenance Lock .....	28
Lubrication .....	29
<b>Machine Inspections</b> .....	<b>30</b>
Pre-Start Inspection Checklist .....	31
Frequent Inspection Checklist .....	32
Annual Inspection Report .....	33
<b>Troubleshooting</b> .....	<b>34</b>
<b>Warning and Instructional Decals</b> .....	<b>35</b>
<b>Transport and Lifting Instructions</b> .....	<b>38</b>
Loading .....	38
Lifting and Tie Down Instructions .....	40

# —Specifications—

<b>4069 ERT</b>		
Working Height*		46 ft      14 m
Platform Height		40 ft      12.2 m
Maximum Drive Height		40 ft      12.2 m
Stowed Height	Top Guardrail	95.5 in.      2.43 m
	Rails Folded	64 in.      1.63 m
	Platform Floor	51 in.      1.3 m
Guardrail Height		43.5 in.      1.11 m
Toeboard Height		6 in.      15 cm
Machine Weight** (Unloaded)		11,000 lb      4,990 kg
Lift Capacity	Total	900 lb      410 kg
	Platform	600 lb      274 kg
	Sheet Material Rack	300 lb      136 kg
Deck Extension Capacity		1 Person / 250 lb (113 kg)
Maximum Occupants		2
Length-Stowed (Overall)		126 in.      3.2 m
Length-Stowed (Without Step)		125 in.      3.18 m
Platform Length (Extended)		166 in.      4.22 m
Platform Length (Retracted)		118 in.      3 m
Width (Overall)		69 in.      1.75 m
Platform Width (Outside)		59 in.      1.5 m
Sheet Rack Width		7 in.      18 cm
Wheel Base		94.5 in.      2.4 m
Turning Radius--Inside		79 in.      2 m
Ground Clearance		10 in.      25 cm
Drive Speed (Proportional)	Platform Stowed	0-3.4 mph      0-5.5 km/h
	Platform Elevated†	0-.5 mph max.†      0-.8 km/h max.†
Gradability		40%/21.8°
Breakover Angle		42%/23°
Optional Outrigger Range Of Motion		10° side to side
Maximum Ground Pressure, Wheel		123 psi      8.6 kg/cm <sup>2</sup>
Maximum Ground Pressure, Outrigger Pad		56 psi      3.9 kg/cm <sup>2</sup>
Maximum Wheel Load		3540 lb      1605 kg
Maximum Operating Wind Speed		28 mph / 12.5 m/sec (45 km/h)
Tire Size		26" x 12" / 66 cm x 33 cm
Tire Pressure		55 psi
Wheel Bolt Torque		55 ft/lb      74.6 Nm
Hydraulic Pressure	Drive System	3700 psi / 255 bar
	Lift System	3200 psi / 220 bar
Hydraulic Fluid Capacity		14 gal / 64 liter
Power System Voltage		48 Volt DC
Battery Charger	Input	100-240 V AC, 50-60 Hz, 1500 W
	Output	48 Volt DC, 20 Amp, Automatic Shut-off
Batteries		Eight 6-Volt deep cycle; 375 Ah @ 20 hour rating
Motor		16 HP (12 kW) 48V Motor

Meets applicable requirements of ANSI A92.6-2006.

\*Working Height adds 6 feet (2 m) to platform height. \*\*Weight may increase with certain options.

†Drive speed while elevated is inversely proportional to platform height; the higher the platform is, the lower the maximum elevated drive speed. The machine is driveable at full height.

# Introduction

---

This Operator's Manual has been designed to provide you, the owner, user or operator, with the instructions and operating procedures essential to properly and safely operate your MEC Aerial Work Platform for positioning personnel, along with their necessary tools and materials, to overhead work locations.



---

***The Operator's Manual must be read and understood prior to operating your MEC Aerial Work Platform. The user/operator should not operate the machine until he/she has been trained and has read and understands the operator's manual as well as having operated the MEC Aerial Work Platform under supervision of an authorized, trained and qualified operator.***

***It is essential that the operator of the aerial work platform is not alone on the workplace during operation.***

***Modifications of this machine from the original design and specifications without written permission from MEC are strictly forbidden. A modification may compromise the safety of the machine, subjecting operator(s) to serious injury or death.***

---

Your MEC Aerial Work Platform has been designed, built, and tested to provide safe, dependable service. Only authorized, trained and qualified personnel shall be allowed to operate or service the machine.

MEC, as manufacturer, has no direct control over machine application and operation. Proper safety practices are the responsibility of the owner, user and operator.

If there is a question on application and/or operation contact:



## **MEC Aerial Platform Sales Corp.**

1401 S. Madera Avenue, Kerman, CA 93630 USA

Toll Free: 1 - 877 - 632 - 5438

Phone: 1 - 559 - 842 - 1500

Fax: 1 - 559 - 842 - 1520

info@MECawp.com

www.MECawp.com

# Safety

**DO NOT** operate this machine until you have read and understood this manual, have performed the Workplace Inspection, Pre-Start Inspection and Routine Maintenance, and have completed all the test operations detailed in the Operating Instructions section.

Failure to read, understand and follow all safety rules, warnings, and instructions could result in serious injury or death. For your safety and the safety of those around you, you must operate your machine as instructed in this manual.

MEC designs aerial work platforms to safely and reliably position personnel, along with their necessary tools and materials, at overhead work locations. The owner/user/operator of the machine should not operate this machine unless properly trained.

ANSI and other applicable standards identify requirements of all parties who may be involved with self-propelled elevating work platforms. The ANSI/SIA A92.6-2006 Manual of Responsibilities is considered a part of this machine and can be found in the manual compartment, located at the platform control station. To ensure safe use of machine, inspections and training specified in ANSI/SIA A92.6-2006 must be performed at designated intervals as prescribed.

## California Proposition 65 Warning

This product contains chemicals known to the State of California to cause cancer and/or birth defects or other reproductive harm.

## Safety Alert Symbols

MEC manuals and decals use symbols and colors to help you recognize important safety, operation and maintenance information.



**RED** – Indicates an imminently hazardous situation which, if not avoided, will result in death or serious injury.



**ORANGE** – Indicates a potentially hazardous situation which, if not avoided, could result in death or serious injury.



**YELLOW with alert symbol** – Indicates a potentially hazardous situation which, if not avoided, may result in minor or moderate injury.



**YELLOW without alert symbol** – Indicates a potentially hazardous situation which, if not avoided, may result in property damage.



**GREEN** – Indicates operation or maintenance information.



## Fall Protection

---

Operators must comply with employer, job site and governmental rules regarding the use of personal protective equipment.

***If required by your employer or job site***, use Personal Fall Protection Equipment (PFPE) when operating this machine.

All PFPE must comply with applicable governmental regulations, and must be inspected and used in accordance with the PFPE manufacturer's instructions.

Fall restraint must be properly attached to a designated anchorage point when driving or operating the machine. Attach only one fall restraint to each anchorage point.

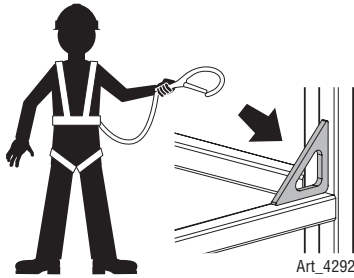

## Electrocution Hazard



**ELECTROCUTION HAZARD! THIS MACHINE IS NOT INSULATED!**

**DEATH OR SERIOUS INJURY will result from contact with or inadequate clearance from any electrically charged conductor.**

**You must maintain a CLEARANCE OF AT LEAST 10 FEET (3.05 m) between any part of the machine, or its load, and any electrical line or apparatus carrying over 300 Volts up to 50,000 Volts. One foot (30.5 cm) additional clearance is required for every additional 30,000 Volts.**

**Observe Minimum Safe Approach Distance.**



Art\_2824



Art\_2823

This machine is **not** electrically insulated and **will not** provide protection from contact with or proximity to electrical current.

Maintain safe distances from electrical power lines and apparatus in accordance with applicable government regulations and the following chart:

### Minimum Safe Approach Distance

Voltage Phase to Phase	Minimum Safe Approach Distance	
	Feet	Meters
0 to 300 Volts	Avoid Contact	
Over 300V to 50kv	10	3.1
Over 50KV to 200KV	15	4.6
Over 200KV to 350KV	20	6.1
Over 350KV to 500KV	25	7.6
Over 500KV to 750KV	35	10.7
Over 750KV to 1000KV	45	13.7

Allow for platform movement, electrical line sway or sag and beware of strong or gusty winds.

Keep away from the machine if it contacts energized power lines. Personnel on the ground or in the platform must not touch or operate the machine until energized power lines are shut off.

Do not use the machine as a ground for welding.

## Tip-over Hazards



Art\_2828

DO NOT exceed the maximum platform capacity. The weight of options and accessories will reduce the rated platform capacity and must be factored into the total platform load. Refer to the decals on the options.

DO NOT elevate the platform when the machine is on a surface that is soft and/or on a slope. STOP if the alarm sounds and the red light illuminates when the platform is raised. Use extreme caution to lower the platform.

**Driving:** DO NOT drive the machine on a slope that exceeds the maximum uphill or downhill slope rating. Slope rating applies to machines in the stowed position.

**Driving in stowed position:** use extreme care and reduce speed when driving across uneven terrain, debris, unstable or slippery surfaces, and near holes or drop-offs.

**Driving with the platform elevated:** DO NOT drive on or near uneven terrain, unstable surfaces, curbs, drop-offs or other hazardous conditions.

DO NOT push off or pull toward any object outside the platform.

Maximum Allowable Side Force

ANSI and CSA
50 lbs (222 N) per person



Art\_2834

**DO NOT DRIVE ON IRREGULAR OR UNSTABLE SURFACE**

DO NOT elevate the platform when wind speeds are in excess of 28 m.p.h. (12.5 m/s). If wind speeds exceed 28 m.p.h. (12.5 m/s) when the platform is elevated, carefully lower the platform and discontinue operation.

DO NOT increase the surface area of the platform (i.e. cover the rails with tarp or plywood). Increased surface area exposed to the wind will decrease machine stability.

DO NOT attach overhanging loads or use the machine as a crane.

DO NOT exceed the Sheet Materials Rack maximum capacity of 300 lbs (136 kg).

DO NOT exceed the maximum sheet area of 48 ft.<sup>2</sup> (4.5 m<sup>2</sup>).

Ensure that material is secure.

NEVER transport tools and materials unless they are firmly secured. Secure all tools and loose materials.

NEVER alter or disable any machine components.

NEVER replace any part of the machine with items of different weight or specification.

NEVER modify or alter the work platform without written permission from MEC.

NEVER place ladders or scaffolds in the platform or against any part of the machine.

NEVER use the machine on a moving or mobile surface or vehicle.

Ensure that all tires are in good condition and lug nuts are properly torqued.

Ensure that air-filled tires are properly inflated.



Art\_2833

**DO NOT PUSH OR PULL OBJECTS OUTSIDE PLATFORM**



Art\_2831

**DO NOT ELEVATE IN WINDY CONDITIONS**



Art\_2832

**DO NOT USE AS CRANE**

## Fall Hazards



Art\_2826

**DO NOT CLIMB ON RAILS**

DO NOT sit, stand or climb on the platform guard rails. Maintain a firm footing on the platform floor at all times.

DO NOT exit the platform when elevated

Keep the platform floor clear of debris.

DO NOT fasten a fall restraint lanyard to an adjacent structure.

Ensure that the platform entry is properly closed and secured before operating the machine.

Operators must comply with employer and job site rules and governmental regulations regarding the use of personal protective equipment.



Art\_2825

**DO NOT EXIT PLATFORM WHEN ELEVATED**

## Collision Hazards



Art\_2835

Check path before moving for equipment, materials or other obstructions.

Check path before moving for overhead obstructions.

Check path before moving for crushing hazards when holding the platform rail.

Reduce travel speed when moving the machine on slopes, when near personnel and obstacles, or when surface conditions are wet, slippery or otherwise limiting.

DO NOT operate in the path of any crane unless the controls of the crane have been locked out and/or precautions have been taken to prevent any possible collision.

Stunt driving and horseplay are PROHIBITED.

Watch for personnel and obstructions below the platform when lowering the platform.

From the ground, pay careful attention to the platform during lowering to avoid collision.



Art\_2829



Art\_2827

## Additional Safety Hazards

---

### Explosion and Fire Hazards

---

DO NOT operate the machine in hazardous locations or locations where potentially flammable or explosive gasses or particles may be present.

### Damaged Machine Hazards

---

Conduct a thorough pre-start inspection of the machine and test all functions before each work shift to check for damage, malfunction and unauthorized modification. Tag and remove a damaged, malfunctioning or modified machine from service. DO NOT use a damaged, malfunctioning or modified machine.

Routine maintenance must be performed by the operator before each work shift. Scheduled maintenance must be performed by a qualified service technician at scheduled intervals. Tag and remove from service any machine that has not had scheduled preventative maintenance performed.

Check that all safety and instructional decals are in place and undamaged.

Check that the operator's, safety and responsibilities manuals are present in the storage container located in the platform. All manuals must be complete, undamaged and readable.

### Bodily Injury Hazards

---

DO NOT operate the machine when there is a hydraulic fluid or air leak. Hydraulic fluid or air under pressure can penetrate and/or burn skin.

All compartments must remain closed and secure during machine operation. Improper contact with components under any cover will cause serious injury. Only trained maintenance personnel should access compartments. The operator should only access a compartment when performing pre-operation inspection.

### Weld Line to Platform Safety (if equipped)

---

Read, understand and follow all warnings and instructions provided with the welding power unit.

Do not connect weld leads or cables unless the welding power unit is turned off at the platform controls.

DO NOT operate unless the weld cables are properly connected.

DO NOT connect the ground lead to the platform.

## Battery Safety

---

### Burn Hazards

---

Batteries contain acid. Always wear protective clothing and eye wear when working with batteries.

Avoid spilling or contacting battery acid. Neutralize battery acid spills with baking soda and water.

### Explosion Hazard

---

Keep sparks, flame and lighted tobacco away from batteries. Batteries emit explosive gas.

### Electrocution Hazard

---

Avoid contact with electrical terminals.

# Controls & Components

## Platform Controls

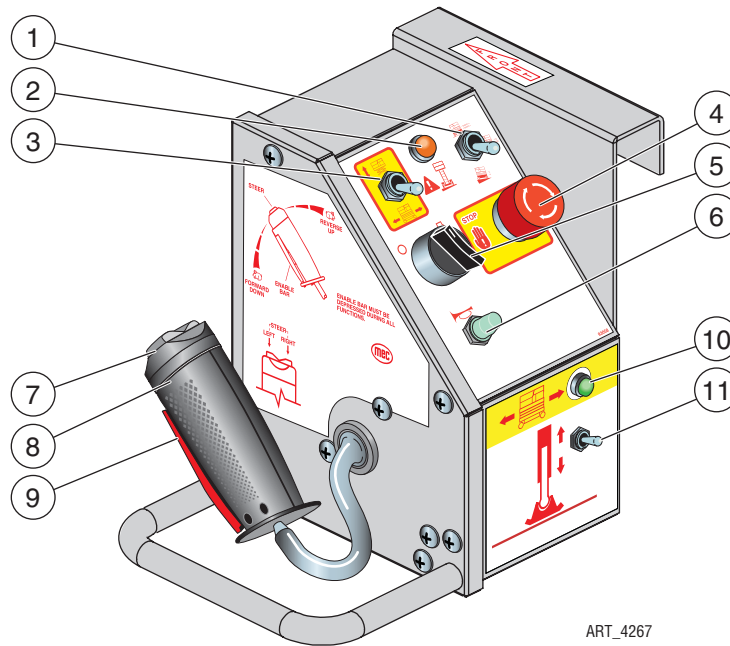

ART\_4267

**WARNING**

***ALWAYS be aware of the machine's position and of your surroundings before activating any control function.***

CONTROL		DESCRIPTION	
1	Speed/Torque Selector Switch	Move this switch to the up position for high speed drive. Move to the middle position for mid-speed/mid-torque drive. Push this switch to the down position for high torque drive.	
2	Tilt Indicator Light	If illuminated, the machine is not level. Carefully lower the platform, then move the machine to a firm, level surface.	
3	Lift/Drive Switch	Move this switch UP to enable the Lift function. Move this switch DOWN to enable the Drive function.	
4	Emergency Stop Switch	Press the EMERGENCY STOP switch at any time to stop all machine functions. Turn switch <i>clockwise</i> to reset.	
5	On/Off Switch	This switch turns power ON or OFF at the platform (does not affect the Lower Controls).	
6	Horn Button (Option)	Press to sound warning horn.	
7	Steer Switch	Using your thumb, press and hold the rocker switch to steer Left or Right.	
8	Control Handle	DRIVE	Proportionally controls Forward and Reverse travel.
		LIFT	Proportionally controls Lift and Lower functions.
9	Enable Bar	Squeeze to enable DRIVE, STEER, and LIFT functions from the Joystick.	
10	Drive Enable Indicator (Outrigger Option)	Lamp ON	Outriggers are retracted and machine will drive.
		Lamp OFF	Outriggers are extended and machine will not drive.
11	Extend/Retract (Outrigger Option)	Push the toggle switch DOWN to extend the outriggers. Continue pushing down until the outriggers stop automatically. Push the toggle switch UP to retract the outriggers.	

## Lower Controls

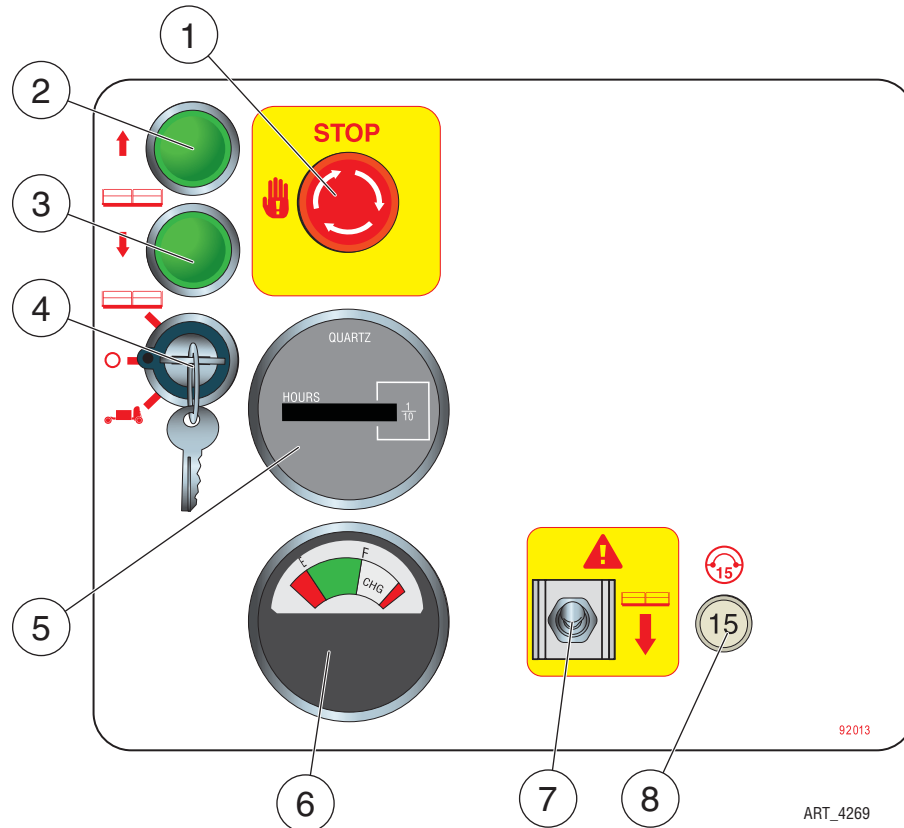

**WARNING**

**ALWAYS be aware of the machine's position and of your surroundings before activating any control function.**

CONTROL		DESCRIPTION
1	Emergency Stop Switch	Press the EMERGENCY STOP switch at any time to stop all machine functions. Turn switch <i>clockwise</i> to reset.
2	Platform Lift Button	Press this button to lift the platform.
3	Platform Lower Button	Press this button to lower the platform.
4	Selector Switch	PLATFORM   Select to operate from the platform control panel.
		BASE   Select to operate from the base control panel.
		OFF   Select to stop operation from either control panel.
5	Hour Meter	Indicates total elapsed time of machine operation.
6	Battery Charge Indicator	Indicated the state of the battery charge.
7	Emergency Down Switch	Move this switch down to lower the platform in the event of an emergency or power loss.
8	Circuit Breaker	Trips when there is excessive electrical load. Push to reset.

# Component Locations

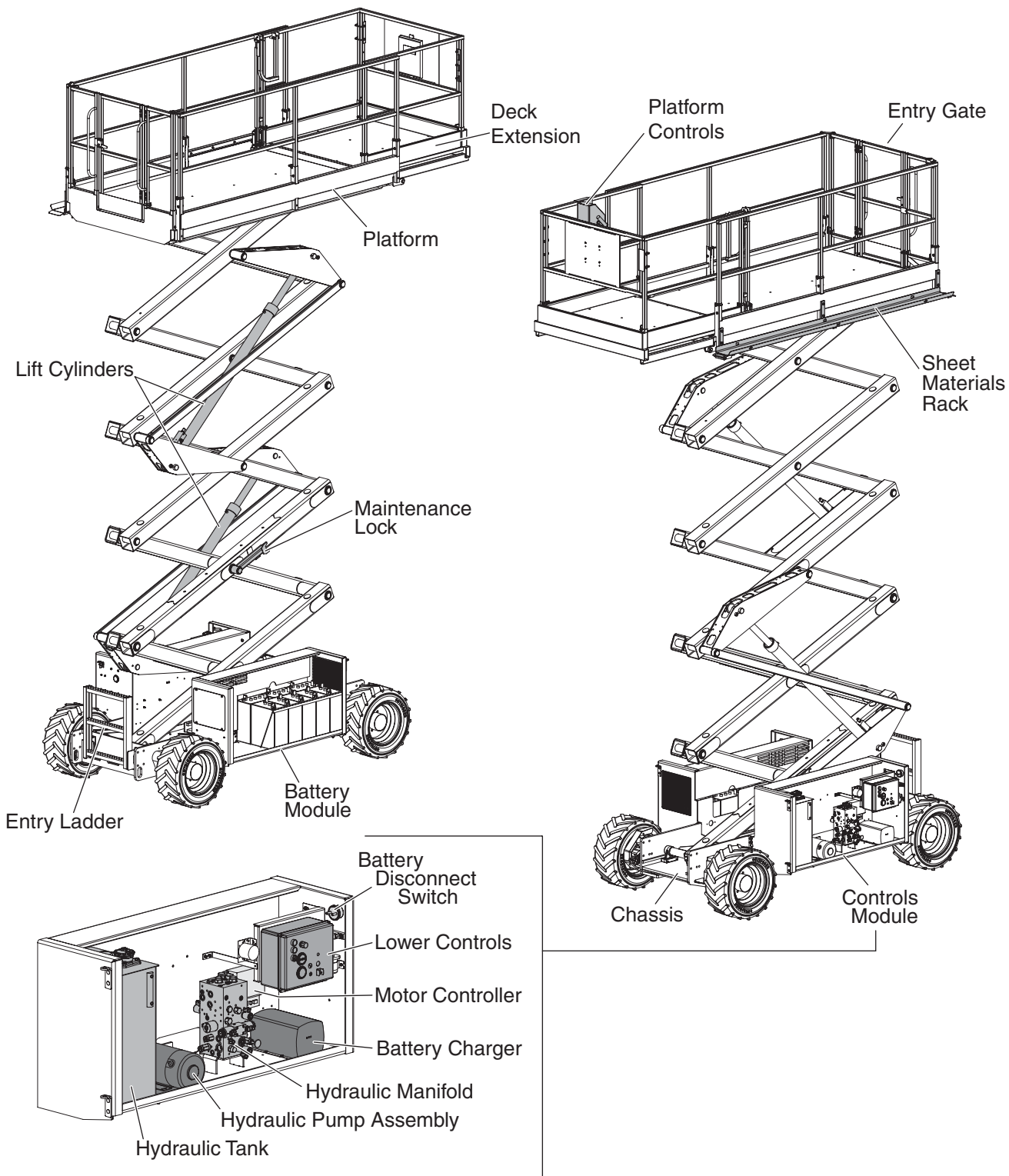

Module Covers removed for clarity

ART\_4266





# Workplace Inspection

---

**DO NOT operate this machine until you have read and understood this manual, have performed the Workplace Inspection, Pre-Start Inspection and Routine Maintenance, and have completed all the test operations detailed in the Operating Instructions section.**

Inspect the workplace and determine whether the workplace is suitable for safe machine operation. Do this before moving the machine to the workplace.

Be sure the lift is the correct machine for the job.

Be aware of workplace conditions, and continue to watch for hazards while operating the machine.

## Workplace Inspection

---

Before operating the machine, check the workplace for all possible hazards, including but not limited to:

- drop-offs or holes, including those concealed by water, ice, mud, etc.
- sloped, unstable or slippery surfaces
- bumps, surface obstructions and debris
- overhead obstructions and electrical conductors
- other objects or equipment
- hazardous locations and atmospheres
- inadequate surface and support to withstand all load forces imposed by the machine
- wind and weather conditions
- the presence of unauthorized personnel
- other possible unsafe conditions

# Operating Instructions & Function Tests

**DO NOT operate this machine until you have read and understood this manual, have performed the Workplace Inspection, Pre-Start Inspection and Routine Maintenance, and have completed all the test operations detailed in the Operating Instructions section.**

This section provides instructions and tests for each function of machine operation. Follow all safety rules and instructions. The operator must conduct inspections and a Functions Test of the machine before each work shift to check that all machine systems are working properly.

Test the machine on a firm level surface with no debris, drop-offs, potholes or overhead obstructions. Perform each step outlined in this section.

This machine shall only be operated by trained and authorized personnel. If multiple operators use this machine, all must be trained, qualified and authorized to use it. New operators must perform a Pre-Start Inspection and Functions Test prior to operating the machine.

Operators must comply with all employer and job site rules and governmental regulations regarding the use of personal protective equipment.

DO NOT use a machine that is malfunctioning. If any function does not perform as described, tag the machine and remove for repair by a qualified service technician. After repairs are completed, a Pre-Start Inspection and Functions Test must be performed before using the machine.

## Prestart

- Perform *Prestart Inspection* (see page 31).
- Check Emergency Stop Switches at both the base and platform controls – turn clockwise to reset.



ART\_3817

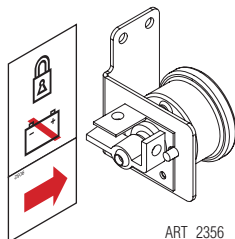

ART\_2356

- Check Battery Disconnect Switch outside the Controls Module. Must be in ON position.

## Base Controls Operation and Test

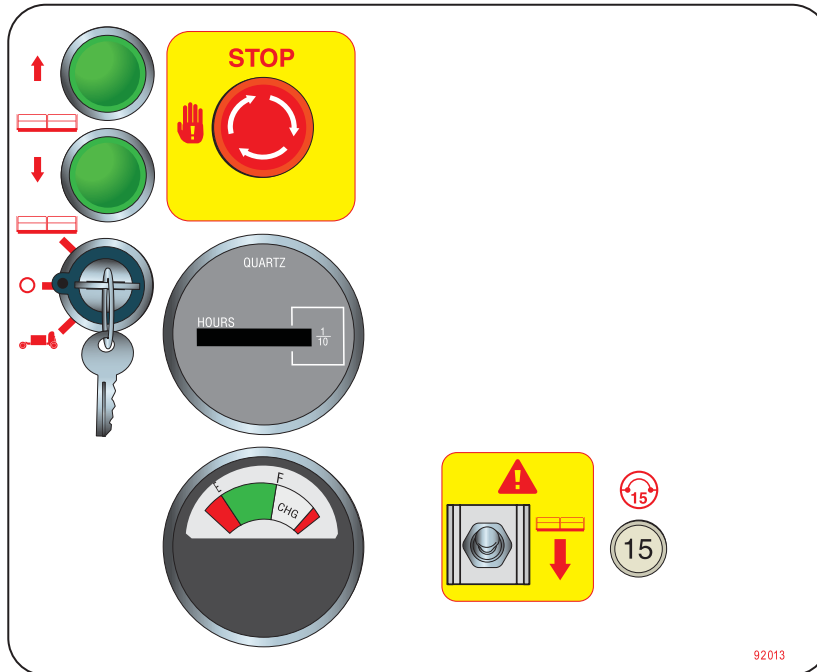

92013

ART\_4269

### WARNING

**Check the area above and around the machine for obstructions before operating the machine. The machine must have space to allow full elevation of platform.**

## Emergency Stop



ART\_3817

- Press the Emergency Stop Switch at any time to stop all machine functions.
- Turn switch *clockwise* to reset.

## Select BASE Operation

- Turn the Selector Key Switch to BASE.

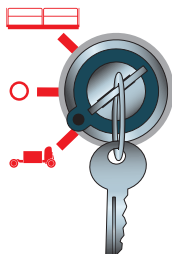

ART\_4271

## Lift/Lower



**Pay careful attention during platform lowering to avoid collision with personnel or objects below.**

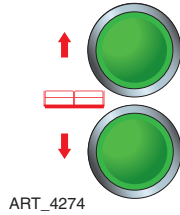

ART\_4274

- Press and hold the Lift button on the Base Control Panel to lift the platform.
- Press and hold the Lower button on the Base Control Panel to lower the platform.

### Test Operation

- Raise the platform until it stops. Platform should lift to full height.
- Lower the platform until it stops. Scissor assembly should close completely.
- Releasing the switch will stop Lift/Lower function.
- Pressing the Emergency Stop Switch will stop lift/lower function.

## Platform Control Operation and Test

### Entering The Platform

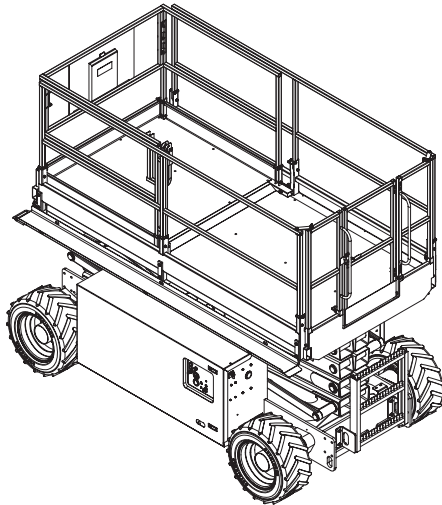

ART\_4275

Personnel shall enter and exit the platform only at the Personnel Entry Gate. When entering or exiting the platform, use the hand holds and entry ladder to maintain three point contact with the machine. Check that the gate is properly secured before operation.

## Platform Control Panel

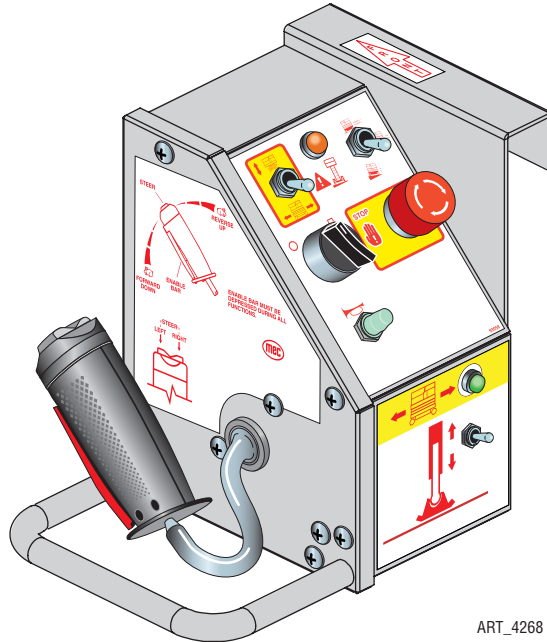

ART\_4268

**IMPORTANT**—Before moving, check that the route of travel to be taken is clear of persons, obstructions, debris, holes, and drop offs, and is capable of supporting the machine.

## Platform Operations Test

### Emergency Stop



ART\_3823

- Press the EMERGENCY STOP switch at any time to stop all machine functions.
- Turn switch *clockwise* to reset.



**Activation of the EMERGENCY STOP switch will apply brakes immediately. This may cause unexpected platform movement as the machine comes to a sudden stop. Brace yourself and secure objects on the platform during operation of machine.**

### Select PLATFORM Operation

- **Base Controls:** Turn the selector switch to PLATFORM.

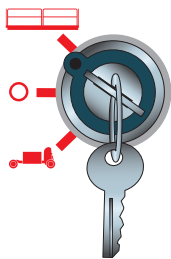

ART\_4273

## Operate from Platform

---

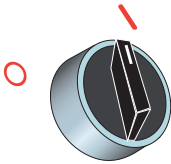

ART\_3826

- Enter the platform through the personnel entry gate. Close and secure the entry.
- Turn the platform selector switch to the ON position.

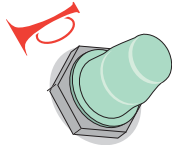

ART\_3824

- Press the Horn Button (if equipped) to verify proper operation.

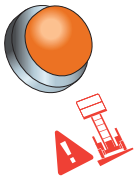

ART\_3825

## Tilt Indicator Light

---

Light ON and alarm sounding indicates an unsafe condition.

- **STOP.** The machine is not level. Carefully lower the platform. Move the machine to a firm, level surface, or if equipped with outriggers, level the machine.

## Control Lever Operation

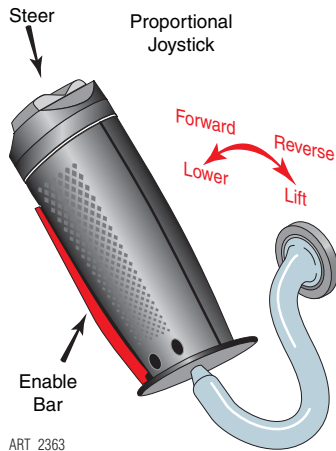

ART\_2363

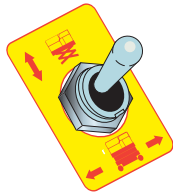

ART\_3828

- Function speed is proportional and is controlled by the movement of the control lever.
- The further it is moved from neutral (center), the faster the speed will be.
- The control lever returns to the neutral (center) position when released.



### WARNING

**Do not elevate platform unless guardrails are installed and secure. If the platform fails to lower DO NOT attempt to climb down the elevating assembly. Serious injury may result.**

## Elevate Platform

- Place the MODE SELECT switch in the LIFT position.
- Squeeze the enable bar and move the control lever toward you.

### Test Operation

- Rate of lift is proportional and is dependent on the movement of the control lever.
- Elevate to maximum height.
- Releasing the enable bar or the control lever will stop elevation.
- Pressing the EMERGENCY STOP switch will stop elevation.

## Lower Platform

- Place the MODE SELECT switch in the LIFT position. Check that no persons or obstructions are in the path of the descending platform.
- Move the control lever away from you.

### Test Operation

- Rate of descent is fixed - platform lowers at same rate regardless of handle position.
- Pressing the EMERGENCY STOP switch will stop descent.



### WARNING

**Check that the route is clear of persons, obstructions, debris, holes and drop-offs, and is capable if supporting the machine.**

**IMPORTANT**—Always check front steer wheel direction before driving.

## Steering

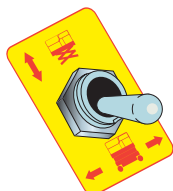

ART\_3827

- Place the MODE SELECT switch in the DRIVE position.
- Squeeze the Enable Bar.
- Press the Steering Switch with your thumb to steer left or right.

### Test Operation

- Releasing the Enable Bar or Steering Switch will stop steering function.
- The steer wheels do not automatically center after a turn. The steer wheels must be returned to the straight-ahead position with the steering switch.

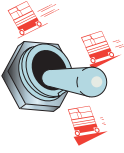

ART\_4276

## Drive Torque (Speed Control)

---

Drive speed is selectable until the platform is elevated above 10 Feet (3 m). When the platform is elevated the machine defaults to creep speed and the switch is locked-out (non functioning).

- HIGH SPEED: allows higher drive speeds for travel across flat ground.
- MID-SPEED/MID-TORQUE: use for moderate slopes.
- HIGH TORQUE: use to drive up or down a steep slope or for careful positioning of the machine.

## Drive Forward

---

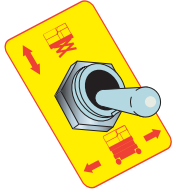

ART\_3827

- Place the MODE SELECT switch in the DRIVE position.
- Squeeze the enable bar and move the control lever away from you.

### Test Operation

- Drive speed is proportional and is dependent on the movement of the control lever.
- Releasing the enable bar or returning the control lever to the center position will stop drive.
- Pressing the EMERGENCY STOP switch will stop drive.

## Drive Reverse

---

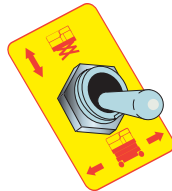

ART\_3827

- Place the MODE SELECT switch in the DRIVE position.
- Squeeze the enable bar and move the control lever toward you.

### Test Operation

- Drive speed is proportional and is dependent on the movement of the control lever.
- Releasing the enable bar or returning the control lever to the center position will stop drive.
- Pressing the EMERGENCY STOP switch will stop drive.

## Brake

---

- For parking, the brake is automatically applied when the control lever is positioned in the neutral (center) position.



## Shutdown Procedure

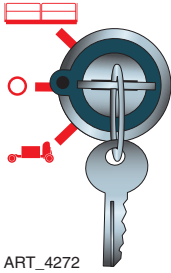

- When finished with the machine, place the platform in the stowed position.
- Park the machine on a level surface.
- Turn the Selector Key Switch to the OFF position and remove the key to prevent unauthorized use.
- Carefully exit the platform using a constant three (3) point dismount/grip.
- Always put the switch in OFF position when leaving the machine at the end of the work day.

## Deck Extension



**CHECK FOR CLEARANCE UNDER DECK AREA BEFORE LOWERING PLATFORM IF THE ROLL-OUT DECK IS EXTENDED.**

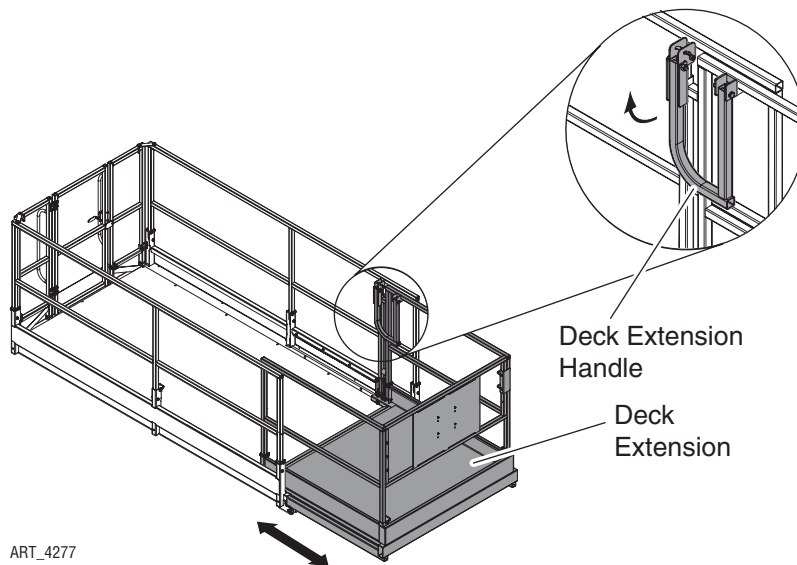

- Swing up the handle at the rear of the extension deck to raise the spring-loaded pin from the locked position.
- With handle raised, push or pull the deck to the desired extended length and release the handle for the spring-loaded pin to lock into position.
- Extensions can be achieved in intervals of 1 inches (2.5 cm) throughout the entire length of the roll-out extension deck.

## Sheet Materials Rack



**DO NOT exceed the Sheet Materials Rack capacity of 300 lbs (136 kg).**  
**DO NOT allow any personnel to stand below the machine when the Sheet Materials is in use.**  
**Fasten the material securely with straps or optional material clamps until use.**

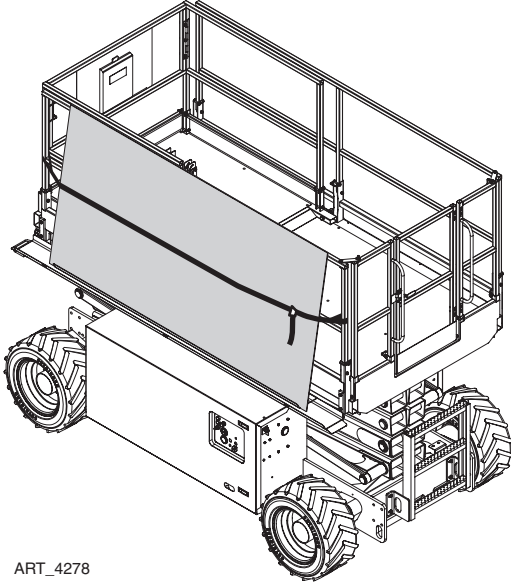

ART\_4278

This machine is equipped with a Sheet Materials Rack. Up to 300 lbs (136 kg) of sheet material may be secured outside the platform to this rack. Maximum size of material on the Sheet Material Rack is 4' x 12' (1.2m x 3.6 m) for outdoor wind loading. All material should be centered on the Sheet Materials Rack.

Fasten the sheets to the platform with straps or optional material clamps until ready to use. Attach the straps to the guardrail of the main platform only. DO NOT fasten the straps to the deck extension guardrail.

Use caution when driving the machine or elevating the platform when the Sheet Material Rack is loaded.

## Optional Material Clamps/Pipe Racks

### WARNING

***The Material Clamps/Pipe Racks may be used only on the Sheet Material Rack side of the platform. DO NOT use on the side opposite the Sheet Material Rack. All material must be centered.***

The optional Material Clamp/Pipe Rack allows the user to hold sheet material in place without the use of straps, or by inverting the clamps, to carry pipe or other long material.

Mount the clamps approximately 8 inches (20 cm) from the ends of the materials, above the Sheet Material Rack. Move the clamps closer together as needed to enable the use of both clamps on shorter material.

### Material Clamp Use

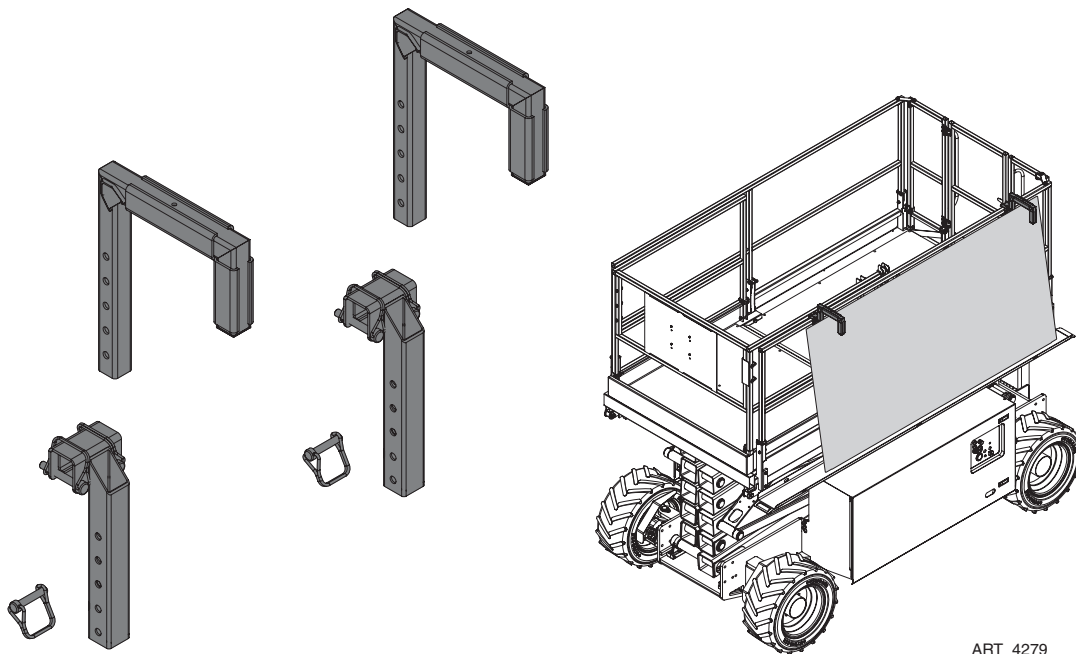

ART\_4279

Remove the J-shaped arms from the Material Clamps when loading material on the Sheet Material Rack.

When all material is loaded, replace the J-shaped arms as shown and secure them in place with the snap pins.

## Pipe Rack Use

### WARNING

**The Sheet Material Rack MAY NOT be used when the Pipe Rack is in use. Maximum capacity is 125 lbs (57 kg) each side/250 lbs (114 kg) total. Maximum length of pipe/long material is 12 feet (3.65 m). Material must be centered on the Pipe Rack. Material must be entirely contained by the arms of the rack and may not extend above the shorter arm.**

### CAUTION

**Use extreme caution and watch for obstructions when driving and lifting/lowering with long material on the rack.**

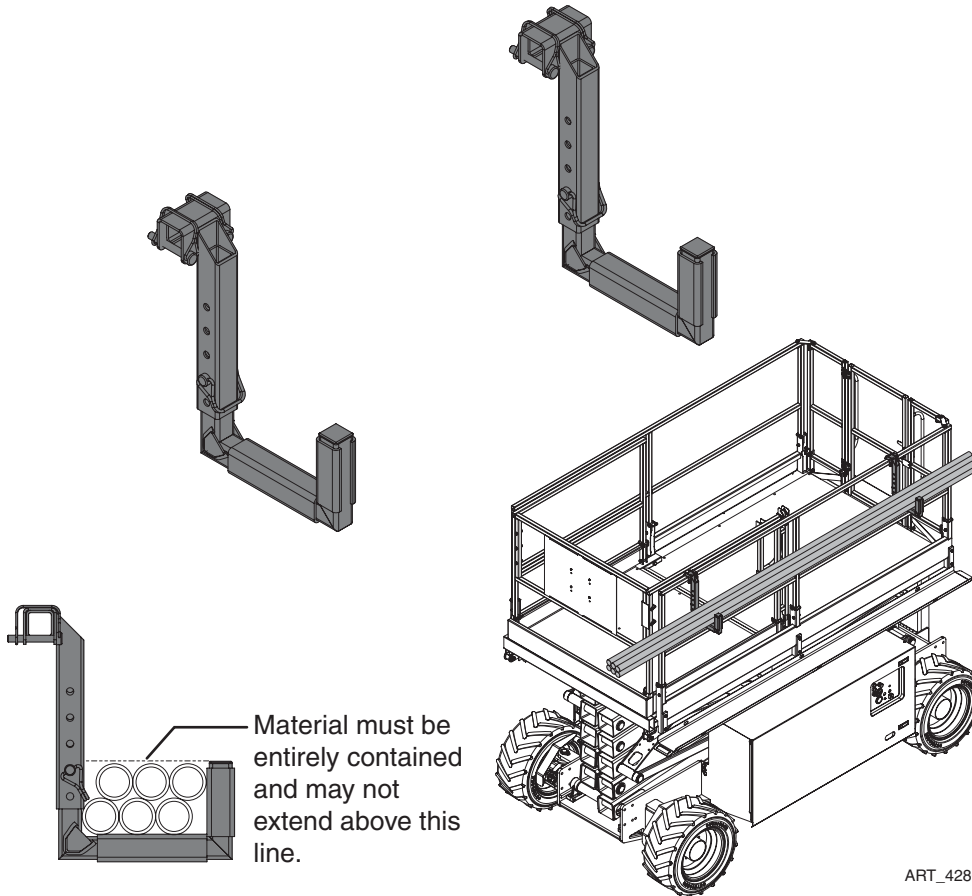

Mount the J-shaped arms as shown for Pipe Rack use.

The maximum permissible length of material is 12 feet (3.65 m). All material must be centered on the Pipe Rack.

## Outrigger Operation (optional)



**WARNING**

**Check that all ground personnel are clear of the machine before deploying the outriggers.**

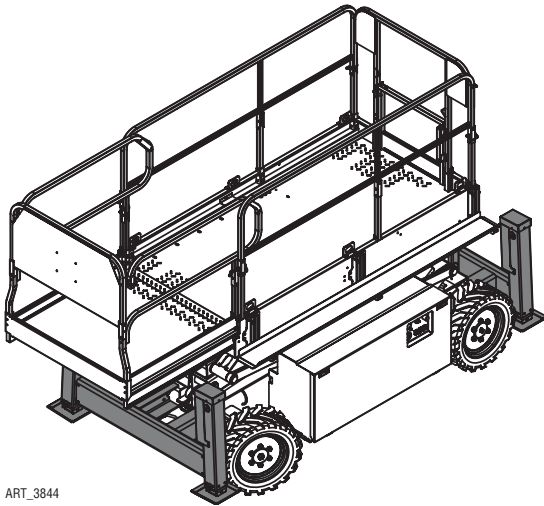

ART\_3844

Lower the outriggers only when the machine is on a firm surface. The surface must be capable of supporting the maximum ground pressure per wheel/outrigger (see Specifications).

The Outrigger Control Switch is located on the front face of the Upper Control Box.

### Extend

Push and hold the Outrigger Control Switch DOWN to extend the outriggers.

- The outriggers will extend and level the machine. When the machine is level and ready to operate, the outriggers will stop automatically.
- The Drive Enable Indicator Lamp will turn OFF, indicating that the outriggers are extended and that machine drive function is disabled.

### Retract

Push and hold the Outrigger Control Switch UP to retract the outriggers.

- The outriggers will retract.
- The Drive Enable Indicator Lamp will turn ON, indicating that the outriggers are retracted and that machine drive function is enabled.

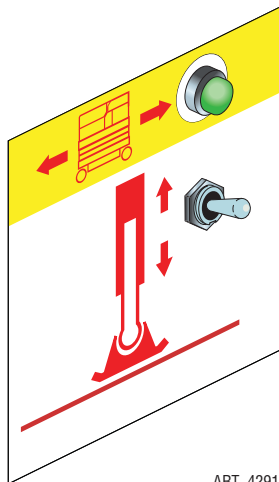

ART\_4291

## Emergency Lowering System



**WARNING**

**If the control system fails while the platform is elevated, use the Emergency Lowering System to safely lower the platform.**

**Do not climb down the scissor assembly or exit the platform.**

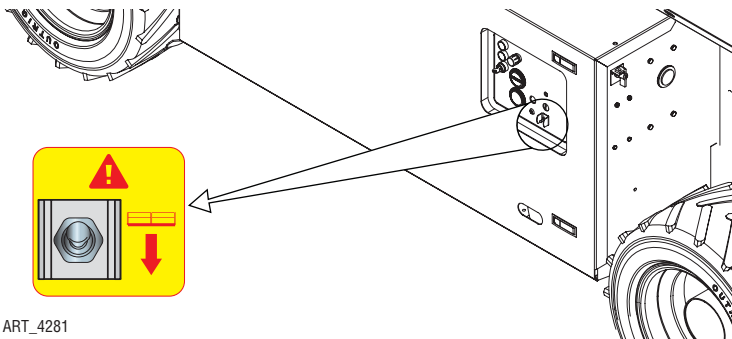

ART\_4281

The Emergency Lowering System is used to lower the platform in case of power failure.

To lower the platform, push down on the Emergency Lowering Switch, located at the Lower Control Box.

## Fold Down Platform Railings

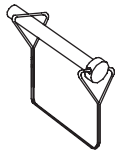

### Spring Pin

18 places. Remove as needed to perform the following steps.

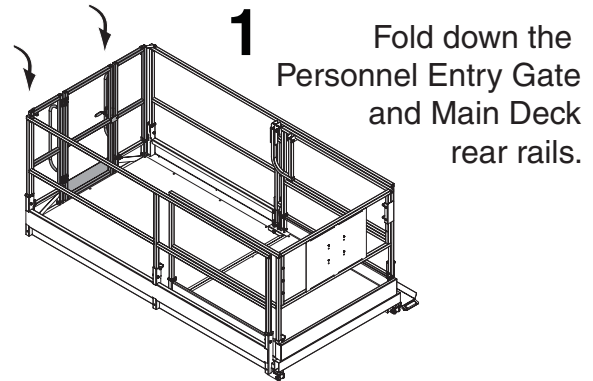

**1**

Fold down the Personnel Entry Gate and Main Deck rear rails.

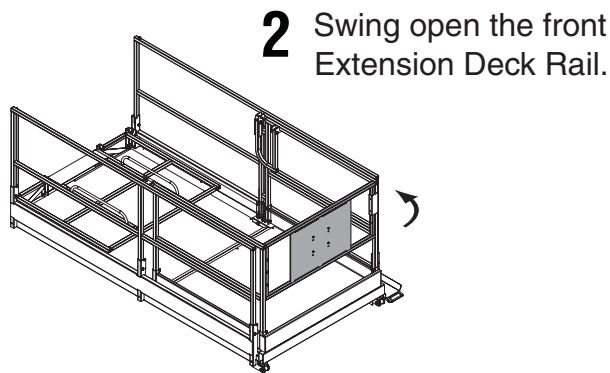

**2**

Swing open the front Extension Deck Rail.

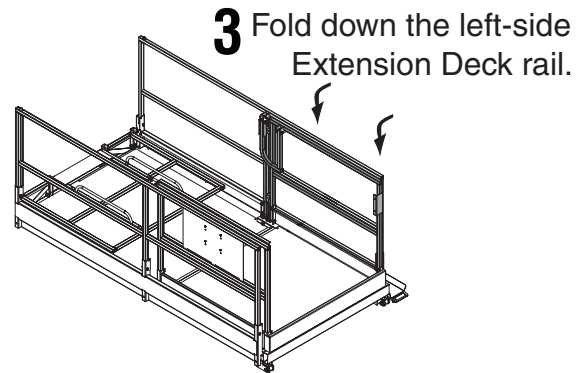

**3**

Fold down the left-side Extension Deck rail.

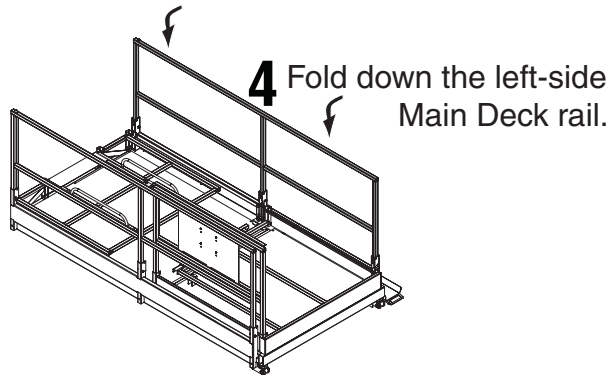

**4**

Fold down the left-side Main Deck rail.

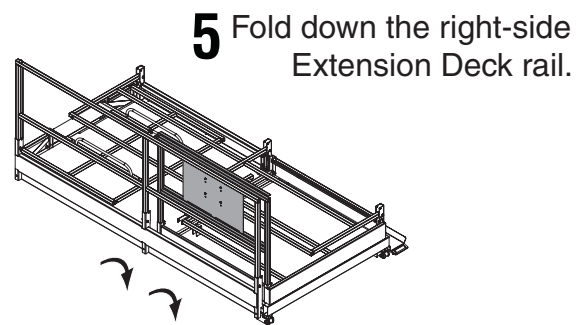

**5**

Fold down the right-side Extension Deck rail.

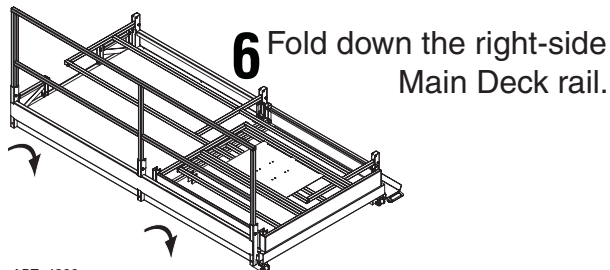

**6**

Fold down the right-side Main Deck rail.

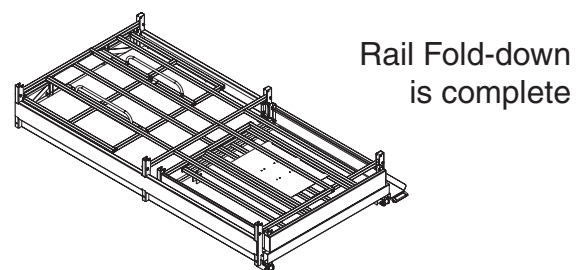

Rail Fold-down is complete

ART\_4288

### To return the machine to normal operation mode:

- Lift all rails into their upright position, then secure them with spring pins
- Check that the Personnel Entry Gate functions properly
- Position the platform control box on the front right rail of the machine.

**DO NOT** use the machine until all closures and guard rails are in position and properly secured.

# Battery Charger

The charger is an advanced, microprocessor controlled, high frequency switching type charger.

The charger will work even with batteries in a severe discharge state with battery terminal voltages as low as 4V. This reduces the need to “boost charge” weak batteries before charging.

The charger has a 22 hour timer in case charging can not be completed due to battery problems. The charger senses and flashes error codes for problems – refer to the *SERVICE MANUAL*.

Battery charger LEDs can be viewed through a window in the door of the Control Module.

**IMPORTANT—** The machine will not operate when charger is plugged in. Be sure to disconnect the charger from the outlet before attempting to operate the unit.

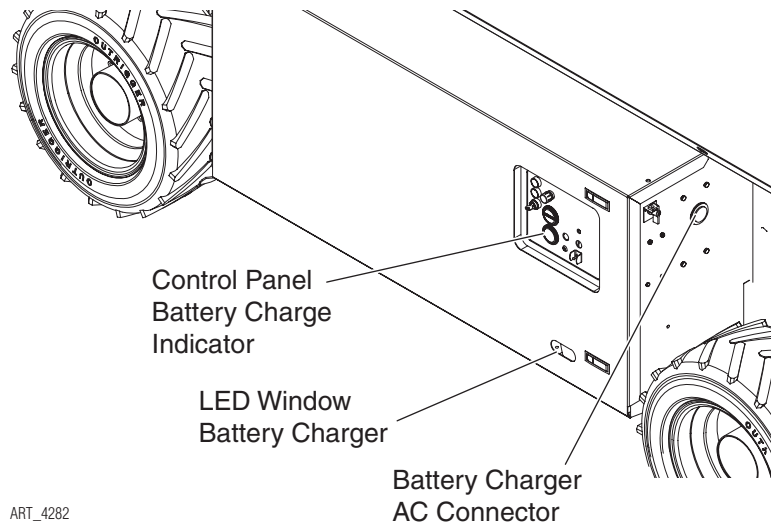

ART\_4282



**WARNING**

**Lead-acid batteries generate explosive gases. Keep sparks and flame away from batteries.**

**No Smoking!**

**The charger surface can get hot while operating. Contact with the skin or surrounding materials should be avoided.**

**To reduce the risk of an electric shock, connect only to a properly grounded single-phase (3 wire) outlet.**

### BATTERY CHARGER INDICATOR

	YELLOW	80%	100%	FAULT
No AC power to charger	OFF	OFF	OFF	OFF
Normal operation, charger is charging	ON	OFF	OFF	OFF
Normal, battery is over 80% charged	ON	ON	OFF	OFF
Normal, battery is 100% charged	OFF	OFF	ON	OFF

Please see service manual for additional information.

**HB1500-48**

ILLUSTRATION No.  
ART\_2374

## Charge Batteries

---

- 1 Plug the charger into a single phase AC socket with a nominal voltage rating of 100V, 110V, 115V, 120V, 220V, 230V, or 240V and a frequency rating of 50 or 60Hz.
  - The charger automatically senses and adjusts to the AC voltage and frequency.
  - **At 110/120V the wall socket circuit breaker or GFCI should be rated for 20A. There should be no other loads on the circuit.**
- 2 The charger will start automatically within a few seconds and begin charging the batteries.
- 3 The LEDs indicate the charging progress.
  - The yellow LED will turn *ON* and remain *ON* throughout the charging cycle.
  - When the battery is 80% charged the green 80% LED will turn *ON*.
  - When the battery is fully charged the green 100% LED will turn *ON* and the green 80% LED will turn *OFF*.
  - When the battery is fully charged the yellow LED will turn *OFF* indicating that the charger is no longer charging.

Charging time is dependent on depth of battery discharge, battery condition, and temperature.

If the charger is left plugged in after charging is complete (100% LED *on*) the charger goes into maintenance mode to keep batteries charged while in storage.

The charger continuously measures battery voltage and restarts the charging cycle if the battery voltage drops below about 50V. This keeps batteries charged while in storage but does not boil-out the electrolyte over time.

Turn *OFF* charger by unplugging (disconnect from AC voltage).

### Red FAULT LED

- **ON:** Battery pack probably bad, weak, or a bad cell.
- **1 FLASH:** Output connection error. Open or short circuit. Remove from service until problem is identified and corrected.
- **2 FLASH:** Charger timed out. Battery pack is severely discharged or is bad, is weak, or contains a bad cell. Unplug for 30 seconds, then plug in to start a new charge cycle.

**Note:** New batteries sometimes need 20 to 30 charge/discharge cycles before they charge normally. The charger LEDs may only show yellow or 80% LED *ON* after overnight charging. Within a few weeks the 100% LED will turn *ON* at the end of the charge cycle.



# Maintenance

---

**DO NOT** operate this machine until you have read and understood this manual, have performed the Workplace Inspection, Pre-Start Inspection and Routine Maintenance, and have completed all the test operations detailed in the Operating Instructions section.

Tag and remove a damaged, malfunctioning or modified machine from service. **DO NOT** use a damaged, malfunctioning or modified machine.

Use the Pre-Start Inspection to determine what Routine Maintenance is required. The operator may perform only the routine maintenance items specified in this manual.

**IMPORTANT**—Scheduled maintenance inspection checklists are included in this manual for use only by qualified service technicians. Only qualified service technicians may perform repairs to the machine. After repairs are completed, the operator must perform a Pre-Start Inspection before proceeding to the Functions Test.



---

**Hydraulic fluid under pressure can penetrate and burn skin, damage eyes, and may cause serious injury, blindness, and death. Repair leaks immediately. Fluid leaks under pressure may not always be visible. Check for pin hole leaks with a piece of cardboard, not your hand.**

---



---

**NEVER perform work or inspection on the machine with the platform elevated without first blocking the scissor assembly with the Maintenance Lock (see page 28).**

**Failure to perform scheduled maintenance at recommended intervals may result in injury or death. Keep maintenance records current and accurate.**

**Immediately report any damage, defect, unauthorized modification or malfunction to your supervisor. Any defect must be repaired prior to continued use. DO NOT use a damaged, modified or malfunctioning machine.**

---



---

**Never leave hydraulic components or hoses open. Plug all hoses and fitting immediately after disassembly to protect the system from outside contamination (including rain).**

**Never open a hydraulic system when there are contaminants in the air.**

**Always clean the surrounding area before opening hydraulic systems.**

**Use only recommended lubricants. Improper lubricants or incompatible lubricants may cause as much damage as no lubrication.**

**Watch for makeshift “fixes” which can jeopardize safety as well as lead to more costly repair.**

**Inspection and maintenance should be performed by qualified personnel familiar with the equipment.**

---

## Routine Maintenance

---

**IMPORTANT**— The operator may perform only maintenance items on the Pre-Start Inspection Checklist. Frequent and Annual maintenance must be performed by qualified service technicians.

**Pre-Start Inspection** Perform routine maintenance as identified in the *Pre-Start Inspection Checklist* on page 31.

## Frequent and Annual Maintenance

---

Frequent Inspection Checklists and Annual Inspection Reports must be completed by qualified service technicians trained and authorized to perform maintenance on this machine, and must be done in accordance with the procedures outlined in the service manual. Scheduled maintenance inspection checklists are included in this manual for use by qualified service technicians.

Machines that have been out of service for more than three months must have the Frequent Inspection Checklists completed before returning to service.

## Maintenance Lock

---



**NEVER perform work or inspection on the machine with the platform elevated without first blocking the scissor assembly with the Maintenance Lock.**

---

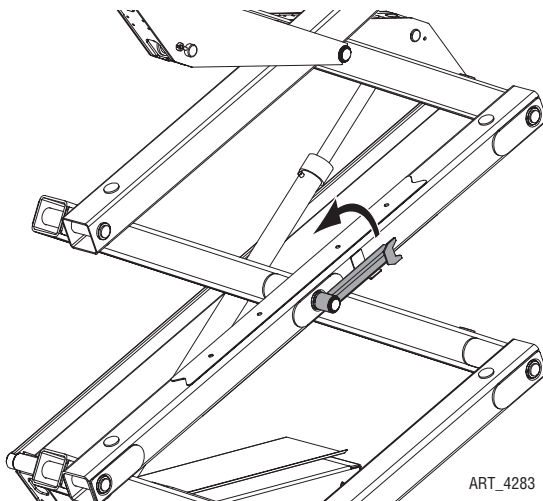

To set the Maintenance Lock, raise the platform enough to allow the Maintenance Lock to rotate to vertical. Carefully lower the platform until the pin above rests securely on the Maintenance Lock.

## Lubrication

Operator may perform routine maintenance only. Lubrication listed as Scheduled Maintenance must be performed by a qualified service technician.

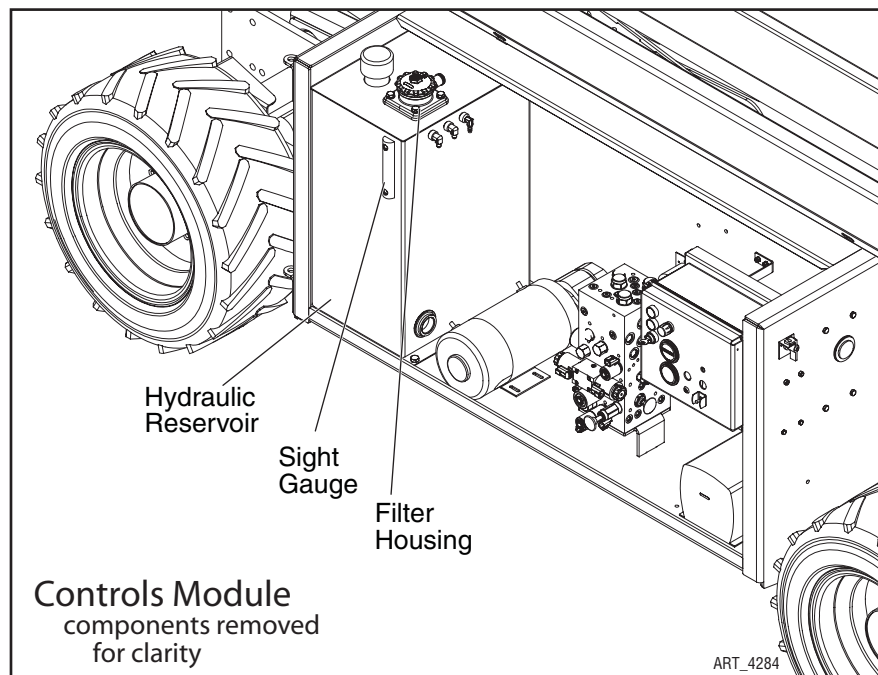

### Lubrication

No.	ITEM	SPECIFICATION	FREQUENCY
1	Hydraulic Reservoir	Mobile Fluid DTE 10, DTE 13 M, or AW32  <b>Do not substitute other fluids as pump damage may result.</b> Fill to the middle of the sight gauge with platform in the stowed position and outriggers (if equipped) retracted.	<b>Routine Maintenance</b> Check sight gauge level daily <b>Scheduled Maintenance</b> Change yearly or every 600 hours, whichever occurs first
2	Hydraulic Filter	Filter Element (located inside Hydraulic Reservoir)	<b>Scheduled Maintenance</b> <b>Normal Conditions</b> Change every six months or 300 hours, whichever occurs first <b>Severe Conditions--very dusty, exceptionally hot or exceptionally cold conditions</b> Change every three months or 150 hours, whichever occurs first

# Machine Inspections

---

**DO NOT** operate this machine until you have read and understood this manual, have performed the Workplace Inspection, Pre-Start Inspection and Routine Maintenance, and have completed all the test operations detailed in the Operating Instructions section.

The operator must conduct a Pre-Start Inspection of the machine and test all functions before each work shift to check for damage, malfunction and unauthorized modification.

Tag and remove a damaged, malfunctioning or modified machine from service. **DO NOT** use a damaged, malfunctioning or modified machine.

Use the Pre-Start Inspection to determine what Routine Maintenance is required. The operator may perform only the routine maintenance items specified in this manual.

**IMPORTANT**— Scheduled maintenance inspection checklists are included in this manual for use only by qualified service technicians. Only qualified service technicians may perform repairs to the machine. After repairs are completed, the operator must perform a Pre-Start Inspection before proceeding to the Functions Test.



---

**Hydraulic fluid under pressure can penetrate and burn skin, damage eyes, and may cause serious injury, blindness, and death. Repair leaks immediately. Fluid leaks under pressure may not always be visible. Check for pin hole leaks with a piece of cardboard, not your hand.**

---



---

**NEVER perform work or inspection on the machine with the platform elevated without first blocking the scissor assembly with the Maintenance Lock (see page 28).**

**Perform scheduled maintenance at recommended intervals. Failure to perform scheduled maintenance at recommended intervals may result in a defective or malfunctioning machine and may result in injury or death of the operator. Keep maintenance records current and accurate.**

**Immediately report any damage, defect, unauthorized modification or malfunction to your supervisor. Any defect must be repaired prior to continued use. DO NOT use a damaged, modified or malfunctioning machine.**

---



---

**Never leave hydraulic components or hoses open. Plug all hoses and fitting immediately after disassembly to protect the system from outside contamination (including rain).**

**Never open a hydraulic system when there are contaminants in the air.**

**Always clean the surrounding area before opening hydraulic systems.**

**Use only recommended lubricants. Improper lubricants or incompatible lubricants may cause as much damage as no lubrication.**

**Watch for makeshift "fixes" which can jeopardize safety as well as lead to more costly repair.**

**Inspection and maintenance should be performed by qualified personnel familiar with the equipment.**

---

## Pre-Start Inspection Checklist

---

The operator must conduct a Pre-Start Inspection of the machine before each work shift.

DO NOT use a damaged or malfunctioning machine.

Initial	Description
_____	Check that the operator's manual and manual of responsibilities are in the storage container located on the platform.
_____	Perform a visual inspection of all machine components. Look for missing parts; torn or loose hoses; hydraulic fluid leaks; loose, torn or disconnected wires; damaged tires; etc.
_____	Check all structural components of the machine for cracked welds, corrosion and collision damage.
_____	Check all hoses and the cables for worn or chafed areas.
_____	Check the platform rails and personnel entry for damage or modification. Check for missing spring pin retainers.
_____	Check that all warning and instructional decals are present, legible and secure.
_____	Check the tires for damage.
_____	Check that all structural components, pins and fasteners are present and properly tightened.
_____	Check for fluid leaks.
_____	Check hydraulic fluid level (check with platform fully lowered).
_____	Check that batteries are clean and secure. Check terminals for proper tightness. Check for corrosion.
_____	Secure all covers, panels and guard rails.
_____	Ensure that the personnel entry is properly closed and secured before operating the machine.

## Frequent Inspection Checklist



***This checklist must be used at 3-month intervals or every 150 hours of machine use, whichever occurs first. Failure to do so could result in death or serious injury.***

Frequent Maintenance Inspections should be conducted by qualified service technicians only. Photocopy this page for reuse. Keep inspections records up to date. Record and report all discrepancies to your supervisor.

**Model Number** \_\_\_\_\_ **Serial Number** \_\_\_\_\_ **Hour Meter Reading** \_\_\_\_\_

Initial	Description
---------	-------------

- |       |   |
|-------|---|
| _____ | Perform all checks listed on Pre-Start Inspection.  |
| _____ | Inspect the condition of hydraulic fluid in the reservoir. Oil should be a clear amber color.                                 |
| _____ | Check battery electrolyte level and connections.  |
| _____ | Check wheel lug bolts for proper torque (see "Machine Specifications").   |
| _____ | Check if tires are leaning in or out.   |
| _____ | Inspect all structure and pivot points for signs of wear and/or damage.   |
| _____ | Check the pin joints and retaining rings for security.  |
| _____ | Inspect the entire machine for signs of damage, broken welds, loose bolts, improper or makeshift repairs.                     |
| _____ | Check that the platform does not drift down with a full load.   |
| _____ | Check all wire connections for tightness and corrosion.   |
| _____ | Check outriggers (if equipped) for proper operation.  |
| _____ | Check the operation speeds to ensure they are within specified limits (see <i>Specifications</i> ).                           |
| _____ | Check the emergency lowering system.  |
| _____ | Clean and lubricate all push button switches with dry lubricant and ensure that the switches operate freely in all positions. |
| _____ | Check the tightness of the platform frame and the linkage pins.   |
| _____ | Check the overall platform and guardrail component security.  |
| _____ | Check the electrical mounting and hardware connections for security.  |
| _____ | Check the steering kingpins for excessive play.   |

### Additional maintenance requirements for severe conditions

- \_\_\_\_\_ If the machine is used in very dusty, exceptionally hot or exceptionally cold conditions, replace hydraulic filter element (under normal conditions replace every 6 months or 300 hours, whichever comes first).

**DATE** \_\_\_\_\_ **INSPECTED BY** \_\_\_\_\_

# Annual Inspection Report



## Annual Inspection Report

**MEC Aerial Platform Sales Corp.**  
 1401 S. Madera Avenue • Kerman, CA 93630 USA  
 877-632-5438 • 559-842-1500 • Fax: 559-842-1520

Date \_\_\_\_\_  
 Serial Number \_\_\_\_\_  
 Model Number \_\_\_\_\_  
 Date Of Last Inspection \_\_\_\_\_  
 Date Placed In Service \_\_\_\_\_

Customer \_\_\_\_\_  
 Street \_\_\_\_\_  
 City/State/Zip \_\_\_\_\_  
 Phone Number \_\_\_\_\_  
 Contact \_\_\_\_\_

Dealer \_\_\_\_\_  
 Street \_\_\_\_\_  
 City/State/Zip \_\_\_\_\_  
 Phone Number \_\_\_\_\_  
 Contact \_\_\_\_\_

- Check each item listed below.
- Use proper Operator's, Service and Parts manual for specific information and settings.
- If an item is found to be "Unacceptable" make the necessary repairs and check the "Repaired" box.
- When all items are "Acceptable", the unit is ready for service.

**Key:** "Y" Yes/Acceptable  
 "N" No/Unacceptable  
 "R" Repaired  
 "U" Unnecessary/Not Applicable

	Y	N	R	U		Y	N	R	U		Y	N	R	U
<b>Decals:</b>					<b>Base:</b>					<b>Operation:</b>				
Proper Placement/Quantity					Cover Panels Secure					Wires Tight				
Legibility					Base Fasteners Tight					Switches Secure				
Correct Capacity Noted					Bolts Tight					All Functions Operational				
<b>Rails:</b>					Front Axle Mounting (4WD)					<b>Emergency Down:</b>				
All Rail Fasteners Secure					Rear Axle Mounting (4WD)					Operational				
Entry Gate/Chain Closes Properly					Front Axle/Front Wheel Assemblies:					Slow Speed Limit Switch:				
Manual/Safety Data In Box					Brakes Operational					Set Properly				
					Wheel Motors-Mounting Secure					<b>Pressures &amp; Hydraulics:</b>				
<b>Extending Platform:</b>					Wheel Motors-Leaks					Oil Filter Secure/Chg				
Slides Freely					Lug Nuts Torqued Properly					Oil Level Correct/Chg				
Latches In Stowed Position					Steering Cylinder Pins Secure					Steering Pressure Set				
Latches In Extended Position					Pivot Points Lubed					Drive Pressure Set				
Rail Latches Work Properly					Rear Axle/Rear Wheel Assemblies:					Lift Pressure Set				
					Brakes Operational					<b>Engine:</b>				
<b>Platform:</b>					Wheel Motors-Mounting Secure					Engine Mounts Tight				
Platform Bolts Tight					Wheel Motors-Leaks					Fuel Lines Secure				
Platform Structure					Lug Nuts Torqued Properly					Fuel Lines Free Of Leaks				
Platform Overload System (if fitted):					<b>Component Area:</b>					Fuel Tanks Secure				
Functional					Valve Manifold(s) Secure					Fuel Shut Off Valves Func.				
Calibrated					Hoses Tight/No Leaks					All Shields/Guards In Place				
<b>Wire Harnesses:</b>					D/C Mtr(s) Secure/Operational					Oil Level				
Mounted Correctly					Contactors Secure					Oil Filter				
Physical Appearance					Pump Secure					Air Filter				
110/220V Outlet Safe/Working					<b>Batteries:</b>					<b>Options Operational:</b>				
<b>Elevating Assembly:</b>					Secure					Outriggers				
Beam Structures					Fully Charged					Hour Meter				
Welds					<b>Battery Charger:</b>					Battery Indicator				
Retaining Rings					Secure					Warning Light				
Upper Cylinder Pins Secure					Operational					Warning Horn				
Lower Cylinder Pins Secure					<b>Emergency Stop:</b>					Generator				
Lower Beam Mounts tight					Breaks All Circuits					Converter				
Rollers Turn Freely														
<b>Maintenance Locks:</b>														
Secure														
Operational														

Comments: \_\_\_\_\_  
 \_\_\_\_\_  
 \_\_\_\_\_

Signature/Mechanic: \_\_\_\_\_  
 Signature/Owner-User: \_\_\_\_\_

Date: \_\_\_\_\_  
 Date: \_\_\_\_\_



# Troubleshooting

---



***Should you experience erratic operation or notice any malfunction while operating this machine, discontinue use immediately.  
Call for assistance and report the incident to your supervisor, and do not use the machine until it has been checked by a trained, qualified mechanic.***

---

## Machine functions will not operate

---

- Master disconnect turned on?
- Batteries properly connected?
- Batteries fully charged?
- Circuit Breaker tripped?
- Function toggle switch or the Enable Bar not activated?
- Selector Key Switch in proper position?
- Both Emergency Stop Switches reset?
- Hydraulic fluid level low?
- Obvious fluid leak or damaged component?
- Wires disconnected, broken, or loose?
- Motor control processor Diagnostic LED OFF?  
LED should be ON. If not ON or FLASHING, refer to Service Manual or contact MEC Technical Support.





Decals

All warning and instructional decals must be present, legible and secure.

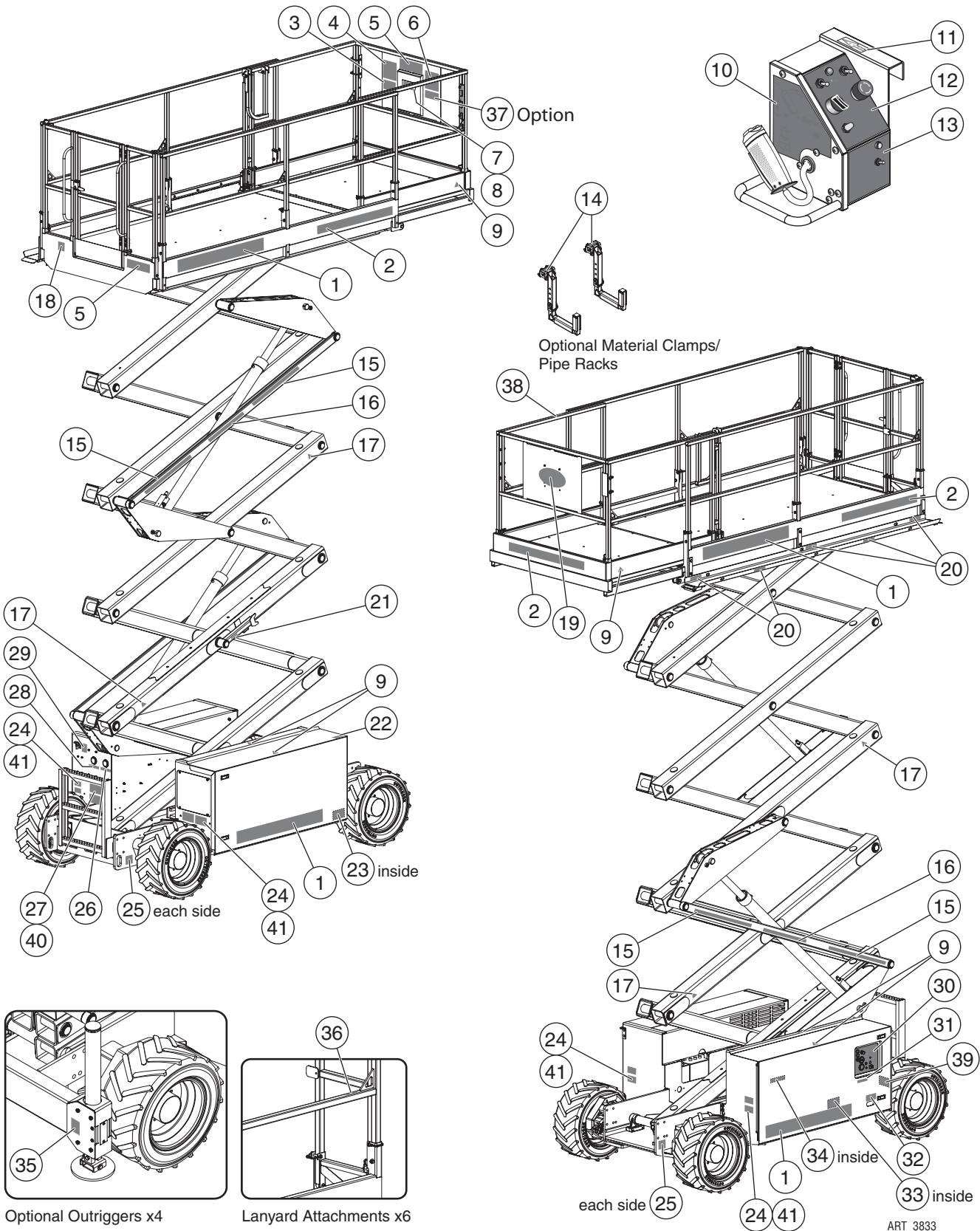

Decals (continued)

- 1 93052  
4 Places  
**mec 4069 ERT**
- 2 92416  
3 Places  
www.mecAWP.COM
- 3 90730  
**WARNING**
- 4 90721  
**DANGER**
- 5 93059  
2 Places
- 6 90722  
**WARNING**
- 7 8911
- 8 90718 (inside case)  
**WARNING**
- 9 91850  
6 Places
- 10 90729
- 11 7156
- 12 93058
- 13 91730 (Option)
- 14 92848 (Option)  
2 Places  
**WARNING**  
PIPE RACK CAPACITY  
125 LBS EACH/250 LBS TOTAL.  
SHEET MATERIAL RACK MAY NOT  
BE USED WHEN PIPE RACK IS IN USE
- 15 7982  
4 Places
- 16 8503  
2 Places  
**KEEP CLEAR**
- 17 9910  
4 Places
- 18 90739  
MADE IN USA
- 19 90719  
**mec**
- 20 93051  
5 Places  
**WARNING**  
MATERIAL RACK CAPACITY  
300 LBS (136 KG)
- 21 90717  
MAINTENANCE LOCK  
REFER TO PARTS AND SERVICE  
MANUAL FOR PROPER USE
- 22 8779  
**WARNING**  
BATTERIES PRODUCE  
EXPLOSIVE GAS.  
CHARGE BATTERIES IN  
WELL VENTILATED AREA  
DO NOT EXPOSE TO  
SPARKS OR FLAMES.
- 23 90726  
**WARNING**  
EACH REPLACEMENT BATTERY MUST WEIGH  
A MINIMUM OF 60 POUNDS (27.2 kg)  
FAILURE TO MEET MINIMUM WEIGHT  
REQUIREMENT MAY CAUSE MACHINE  
INSTABILITY.
- 24 90725  
4 Places  
**WARNING**  
REPLACE TIRES WITH MANUFACTURER'S  
EQUIPMENT ONLY.  
FAILURE TO USE MANUFACTURER'S  
TIRES MAY CAUSE MACHINE INSTABILITY.  
REFER TO SERVICE AND PARTS MANUAL  
FOR REPLACEMENT PART NUMBER.
- 25 11026730  
4 Places
- 26 90751  
POWER TO PLATFORM
- 27 92767
- 28 90750  
BATTERY CHARGER
- 29 9052
- 30 92013
- 31 90268  
PLATFORM CAPACITY  
600 LBs (272kg)
- 32 91956  
BATTERY CHARGER INDICATOR
- 33 92089
- 34 6873  
HYDRAULIC OIL
- 35 9465 (Option)  
4 Places
- 36 8605  
6 Places  
CERTIFIED LANYARD  
ANCHORAGE POINT
- 37 8606 (option)  
**WARNING**  
LANYARD ANCHORAGE POINTS ARE RECOMMENDED  
FOR WORK PRACTICES RESTRICTIONS ONLY.  
USE OF FALL ARREST SYSTEMS ATTACHED TO  
ANCHORAGE POINTS ON MOBILE EQUIPMENT  
MAY CAUSE MACHINE TO TIP, RESULTING IN  
SERIOUS INJURY OR DEATH.
- 38 7155  
LOCATE CONTROL BOX HERE
- 39 90732  
**WARNING**  
DO NOT POWERMAN ON  
SPRING ASSISTANCE  
CONNECTIONS OR  
CONNECTORS OR  
REPAIRS MAY CAUSE  
DAMAGE AND/OR  
SERIOUS INJURY
- 40 92054  
Multiple Patents  
Pending
- 41 8502  
4 Places  
INFLATE TO TIRE  
MANUFACTURER'S MAX.  
SPECIFICATIONS  
OR SEE  
SERVICE MANUAL

**mec**  
ILLUSTRATION No.  
ART\_4290



# Transport and Lifting Instructions

## Safety Information



**WARNING**

*This section is provided for reference and does not supersede any government or company policy regarding the loading, transport or lifting of MEC machinery.*

*Truck drivers are responsible for loading and securing machines, and should be properly trained and authorized to operate MEC machinery. Drivers are also responsible for selecting the correct and appropriate trailer according to government regulations and company policy. Drivers must ensure that the vehicle and chains are strong enough to hold the weight of the machine. See the serial number plate for machine weight.*

## Loading

### Free-wheel configuration for Winching or Towing.



**DANGER**

#### **RUNAWAY HAZARD!**

*After releasing the brakes there is nothing to stop machine travel. Machine will roll freely on slopes. ALWAYS chock the wheels before manually releasing the brakes.*

The machine can be winched or towed short distances at speeds not to exceed 5 MPH (8.05 kph). Before towing or winching the machine, it is necessary to release the brakes. Reset the brakes after towing or winching.

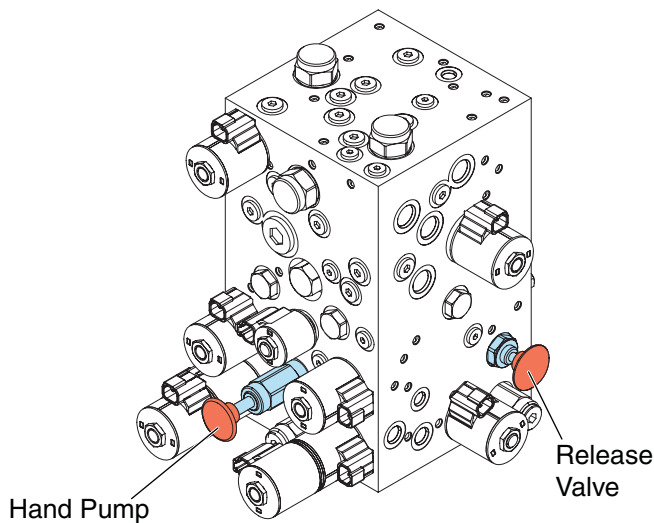

ART\_4293

### Disengage Brakes before Towing or Winching

- Chock the wheels.
- Push and hold the release valve.
- Using the hand pump on the manifold, pump valve until pressure is built and valve cannot be pumped.
- Machine is now ready for towing.

### Engage Brakes before Driving

- Pull out the manual brake release valve to reset brakes.

Brakes will reset automatically when drive function is activated.

## Driving or Winching onto or off of a Transport Vehicle

### WARNING

**Always attach the machine to a winch when loading or unloading from a truck or trailer by driving. Read and understand all safety, control, and operating information found on the machine and in this manual before operating the machine.**

- Attach the machine to a winch.
- Remove all machine tie downs. Remove wheel chocks.

#### Driving

- Turn the Base Key Switch to PLATFORM. Check that the Emergency Stop Switch is reset by turning it clockwise.
- Enter the platform and reset the Platform Emergency Stop Switch.
- Test platform control functions.
- Carefully drive the machine off the transport vehicle with the winch attached.

**Note:** The brakes are automatically released for driving and will automatically apply when the machine stops.

#### Winching

- Disengage brakes (see *Disengage Brakes before Towing or Winching* on page 38).
- Carefully operate the winch to lower the machine down the ramp.
- Chock the wheels and engage the brakes.

## Securing to Truck or Trailer for Transport

- Turn the key Selector Key Switch to OFF and remove the key before transport.
- Inspect the entire machine for loose or unsecured items.
- Use chains or straps of ample load capacity.
- Use a minimum of four (4) chains or straps.
- Adjust the rigging to prevent damage to the chains and the machine.

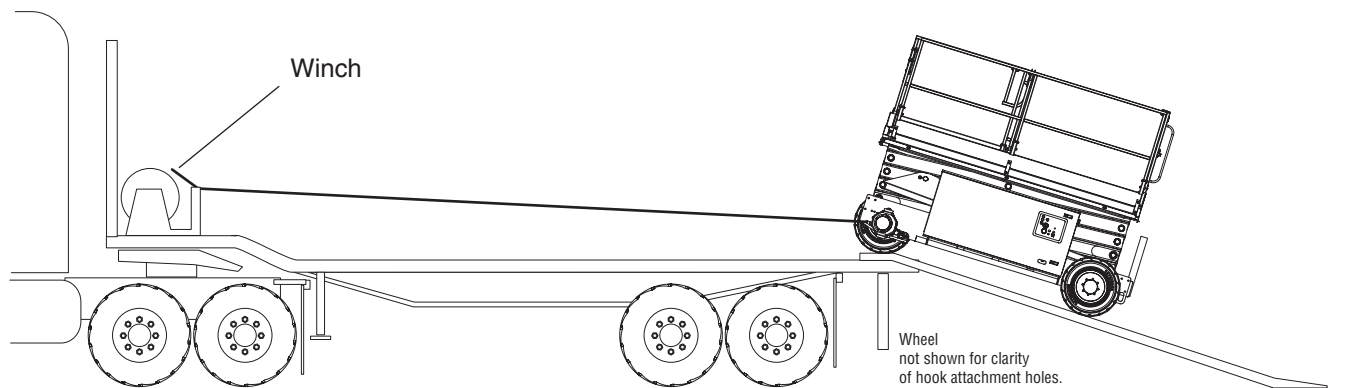

### Truck Tie Down Minimum 4 chains of adequate capacity

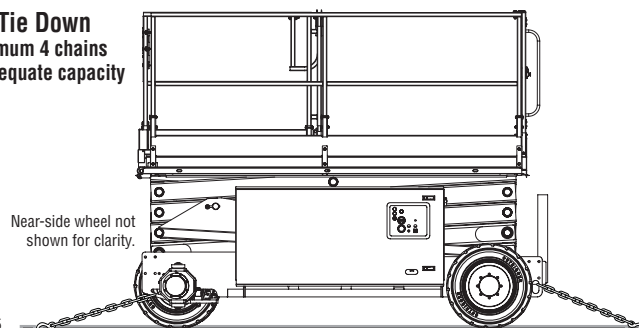

ART\_4285

# Lifting and Tie Down Instructions

## Lifting Instructions



**Only qualified riggers should rig and lift the machine.**

**Ensure that the crane, loading surfaces, spreader bars, cables, chains and straps are of sufficient capacity to withstand the machine weight. See the serial plate for the machine weight.**

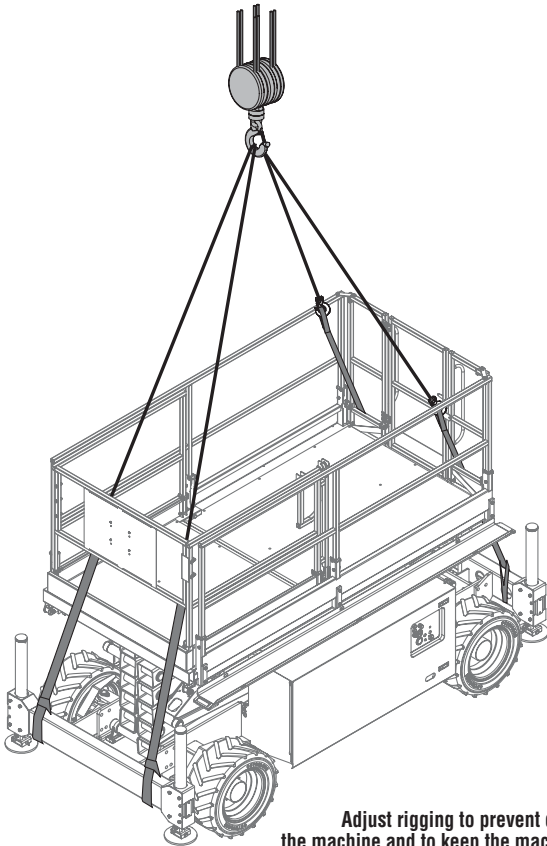

Adjust rigging to prevent damage to the machine and to keep the machine level.

Fully lower the platform. Be sure the deck extension is retracted and the module doors are closed and secure. Remove all loose items from the machine.

Determine the center of gravity of the machine.

Attach rigging to the designated lift points *only*.

For machines NOT equipped with outriggers, use two lengthwise spreader bars set to 128" length. Attach rigging to the lift/tie-down points on the chassis. Route the rigging to avoid damage to the guardrails.

**Use only slings for outrigger-equipped machines.**

Attach the slings to the outrigger weldments as close to the outriggers as possible. Route the rigging as shown to avoid damage to the guardrails.

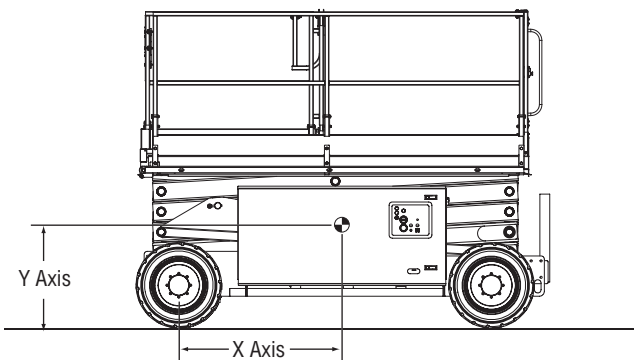

Center of Gravity	X Axis	Y Axis
4069	49.5" (126 cm)	25.5" (65 cm)

ART\_4286





## **Limited Owner Warranty**

---

MEC Aerial Platform Sales Corp. warrants its equipment to the original purchaser against defects in material and/or workmanship under normal use and service for one (1) year from date of registered sale or date the unit left the factory if not registered. MEC Aerial Platform Sales Corp. further warrants the structural weldments of the main frame and scissor arms to be free from defects in material or workmanship for five (5) years from date of registered sale or date unit left the factory if not registered. Excluded from such warranty is the battery(s) which carries a ninety (90) day warranty from described purchase date. Warranty claims within such warranty period shall be limited to repair or replacement, MEC Aerial Platform Sales Corp's option, of the defective part in question and labor to perform the necessary repair or replacement based on MEC Aerial Platform Sales Corp's then current flat rate, provided the defective part in question is shipped prepaid to MEC Aerial Platform Sales Corp. and is found upon inspection by MEC Aerial Platform Sales Corp. to be defective in material and/or workmanship. MEC Aerial Platform Sales Corp. shall not be liable for any consequential, incidental or contingent damages whatsoever. Use of other than factory authorized parts; misuse, improper maintenance, or modification of the equipment voids this warranty. The foregoing warranty is exclusive and in lieu of all other warranties, express or implied. All such other warranties, including implied warranties of merchantability and of fitness for a particular purpose, are hereby excluded. No Dealer, Sales Representative, or other person purporting to act on behalf of MEC Aerial Platform Sales Corp. is authorized to alter the terms of this warranty, or in any manner assume on behalf of MEC Aerial Platform Sales Corp. any liability or obligation which exceeds MEC Aerial Platform Sales Corp's obligations under this warranty.



**MEC Aerial Platform Sales Corp.**

1401 S. Madera Avenue, Kerman, CA 93630 USA

Toll Free: 1 - 877 - 632 - 5438

Phone: 1 - 559 - 842 - 1500

Fax: 1 - 559 - 842 - 1520

[info@MECawp.com](mailto:info@MECawp.com)

[www.MECawp.com](http://www.MECawp.com)

4069 ERT

93072