



Section 5

SCHEMATICS

CONTENTS	PAGE
Hydraulic Schematics Table	5-2
Hydraulic Schematics -- Early Machines	5-3
Hydraulic Schematics -- Later Machines	5-6
Electrical Schematics -- Early Machines	5-9
Electrical Schematics -- Later Machines	5-13
Controls	5-16

FIGURES	PAGE
Hydraulic Schematic, Early Machines	5-3
Functions Manifold, Early Machine	5-4
Pothole & Outrigger Valve Assemblies, Early Machines	5-5
Hydraulic Schematic, Later Machines	5-6
Functions Manifold, Later Machine	5-7
Electrical Schematic -- Early Machines, 1 of 3	5-9
Electrical Schematic -- Early Machines, 2 of 3	5-10
Electrical Schematic -- Early Machines, 3 of 3	5-11
Electrical Schematic -- Later Machines, 1 of 3	5-13
Electrical Schematic -- Later Machines, 2 of 3	5-14
Electrical Schematic -- Later Machines, 3 of 3	5-15
Lower Controls	5-16
Upper Controls	5-16

HYDRAULIC SCHEMATICS TABLE

The Callout designations on the following table apply to Figure 5-1 through Figure 5-5.

Callout	Description
CV1	Check Valve
CV2	Check Valve
HP1	Hand Pump
LS1	Load Sense
MLF	Motor, Left Front
MLR	Motor, Left Rear
MP1	Manual Brake Engage/Release
MRF	Motor, Right Front
MRR	Motor, Right Rear
OD1	Orifice Disk
ORF1	Orifice
ORF2	Orifice
ORF3	Orifice
ORF4	Orifice
ORF5	Orifice
ORF6	Orifice
ORF7	Orifice
PS1	Pressure Switch, Outrigger
PS2	Pressure Switch, Outrigger
PS3	Pressure Switch, Outrigger
PS4	Pressure Switch, Outrigger
RV1	Relief Valve, Steer
RV2	Relief Valve, Lift
RV3	Relief Valve, Drive

Callout	Description
RV4	Relief Valve, 2659 Lift Cylinder
RV5	Relief Valve, 3259 Lower Lift Cylinder
RV6	Relief Valve, 3259 Upper Lift Cylinder
SV1	Solenoid Valve, Drive Directional
SV2	Solenoid Valve, Steer
SV3	Solenoid Valve, Lift/Drive
SV4	Solenoid Valve, Series/Parallel Drive
SV5	Solenoid Valve, Drive Directional
SV6	Solenoid Valve, Series/Parallel Drive
SV7	Solenoid Valve, Pothole Extend
SV8	Solenoid Valve, Pothole Retract
SV9	Solenoid Valve, Pothole Retract
SV10	Solenoid Valve, Outrigger
SV11	Solenoid Valve, 2659 Down
SV12	Solenoid Valve, 3259 Down, Lower Cylinder
SV13	Solenoid Valve, 3259 Down, Upper Cylinder
SV14	Solenoid Valve, Outrigger Retract
SV15	Solenoid Valve, Outrigger Retract
SV16	Solenoid Valve, Outrigger Extend
SV17	Solenoid Valve, Outrigger Extend
SV18	Solenoid Valve, Outrigger Retract
SV19	Solenoid Valve, Outrigger Retract
SV20	Solenoid Valve, Outrigger Extend
SV21	Solenoid Valve, Outrigger Extend

HYDRAULIC SCHEMATICS -- EARLY MACHINES

Figure 5-1: Hydraulic Schematic, Early Machines

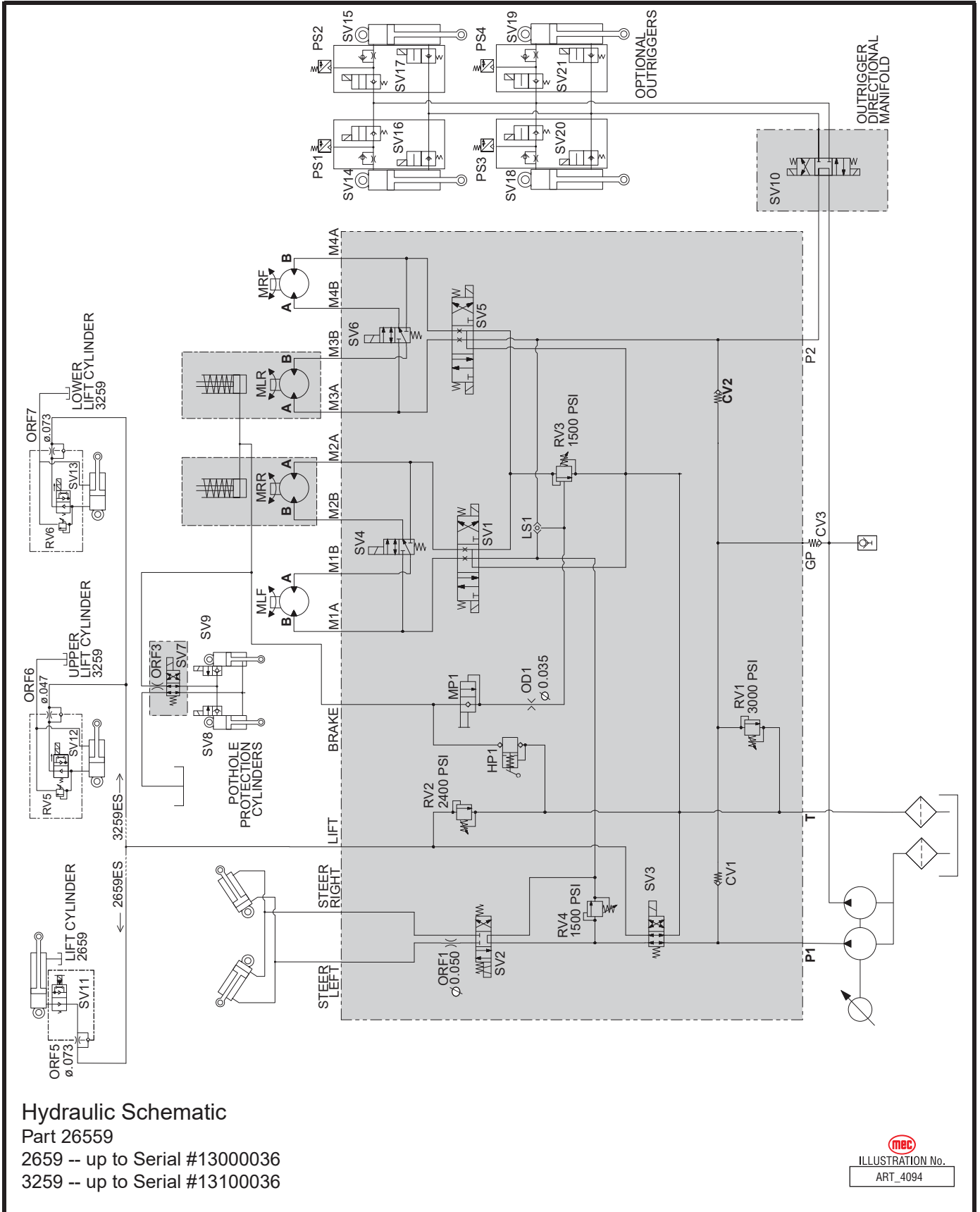

Hydraulic Schematic

Part 26559

2659 -- up to Serial #13000036

3259 -- up to Serial #13100036

MEC
ILLUSTRATION No.
ART_4094

Figure 5-2: Functions Manifold, Early Machine

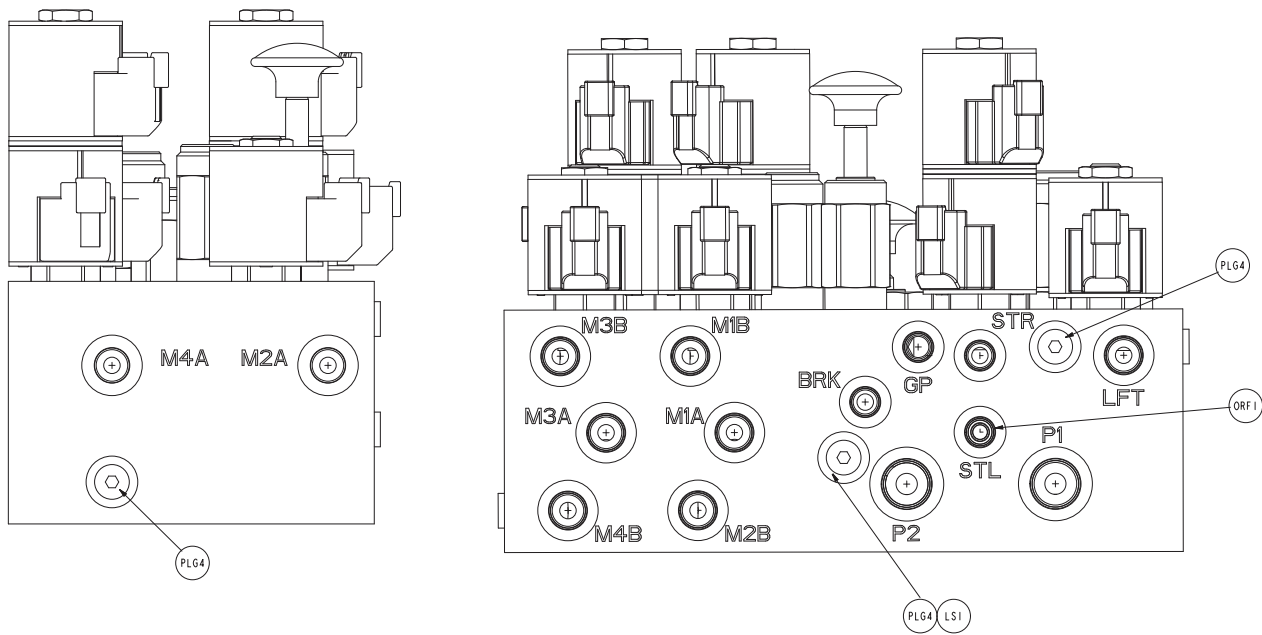

VALVE IDENTIFICATION

POS	FUNCTION	POS	FUNCTION
CV1	PUMP SEPARATION	RV3	COUNTERBALANCE VALVE
CV2	PUMP SEPARATION	RV4	RELIEF VALVE - STEER
HP1	EMR BRAKE REL PUMP	SV1	DRIVE VALVE LF & RR
LS1	LOAD SHUTTLE - BRAKE	SV2	STEER VALVE
MP1	EMR BRAKE REL VALVE	SV3	LIFT VALVE
OD1	BRAKE REL ORIFICE	SV4	TORQUE VALVE
ORF1	STEER SPEED ORIFICE	SV5	DRIVE VALVE RF & LR
RV1	RELIEF VALVE - MAIN	SV6	TORQUE VALVE
RV2	RELIEF VALVE - LIFT		

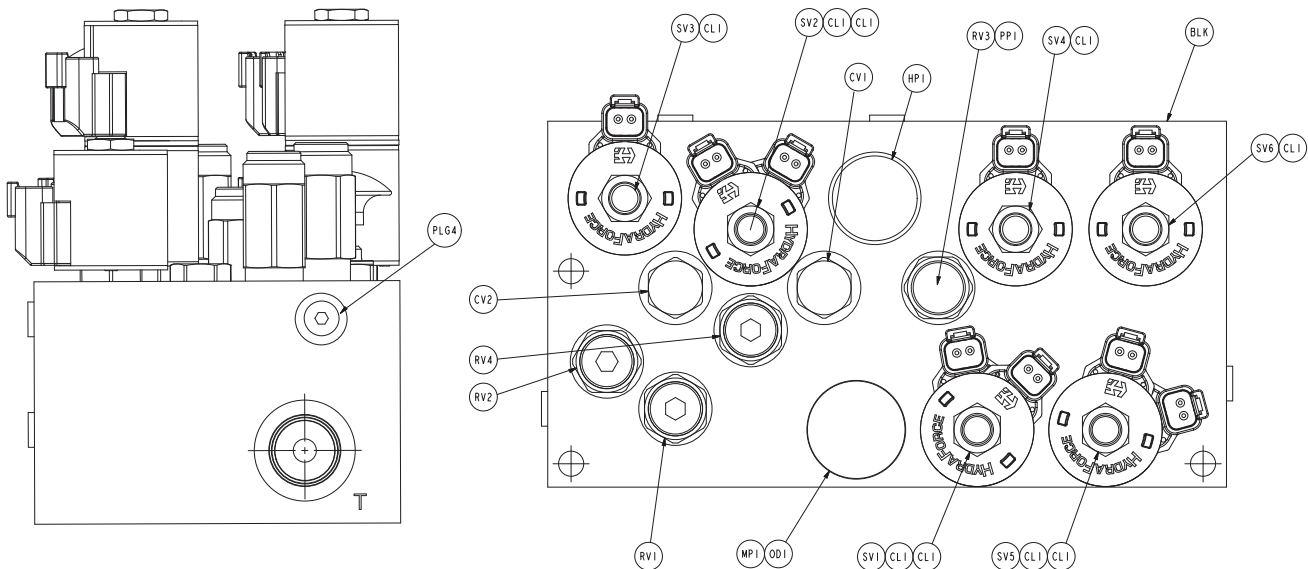

Function Manifold Valve Identification

Part 92561

2659 -- up to Serial #13000036

3259 -- up to Serial #13100036

ILLUSTRATION No.
ART_4098

Figure 5-3: Pothole & Outrigger Valve Assemblies, Early Machines

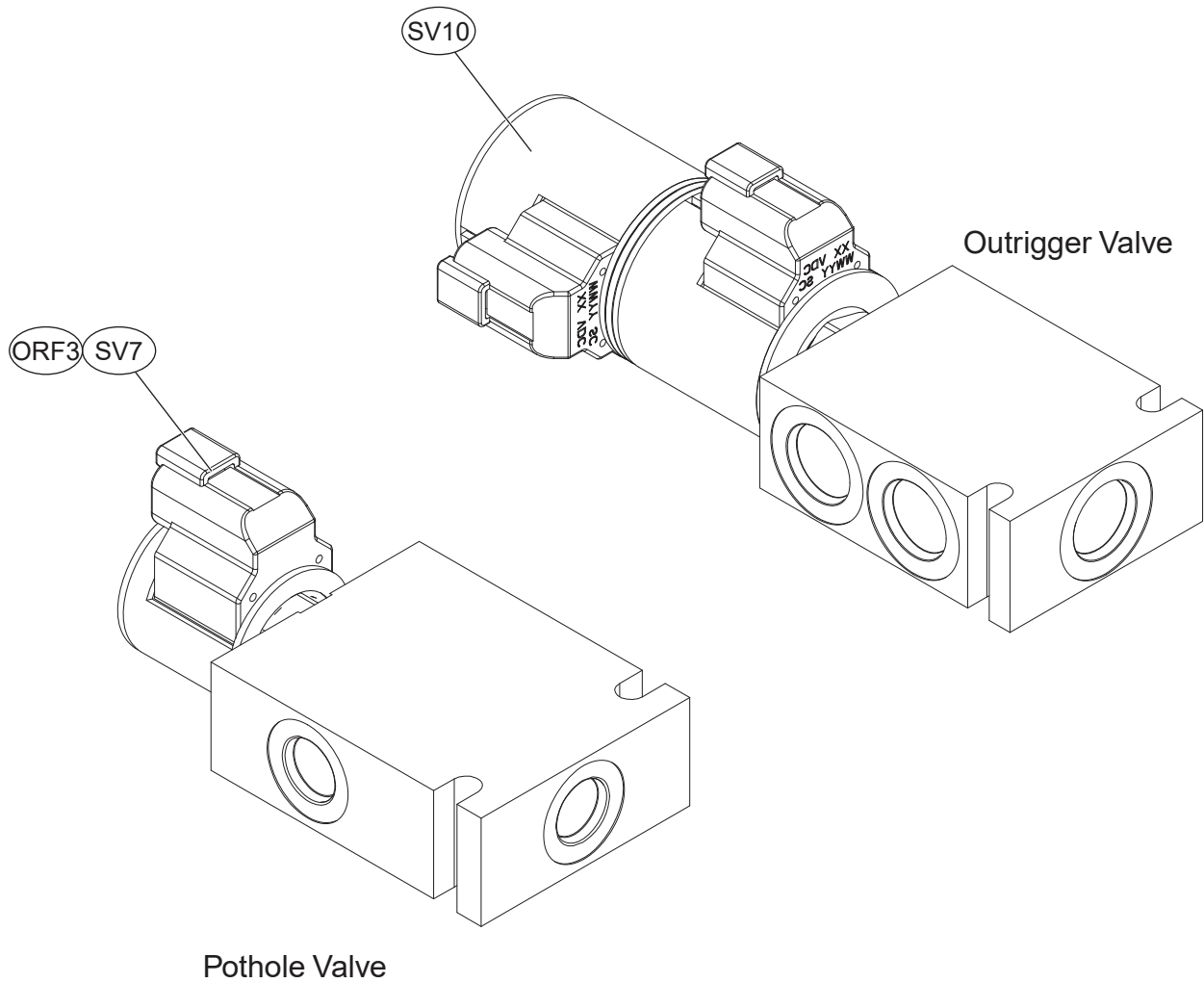

Pothole & Outrigger Valve Identification

Part 92379 & 92890

2659 -- up to Serial #13000036

3259 -- up to Serial #13100036

ILLUSTRATION No.
ART_4097

HYDRAULIC SCHEMATICS -- LATER MACHINES

Figure 5-4: Hydraulic Schematic, Later Machines

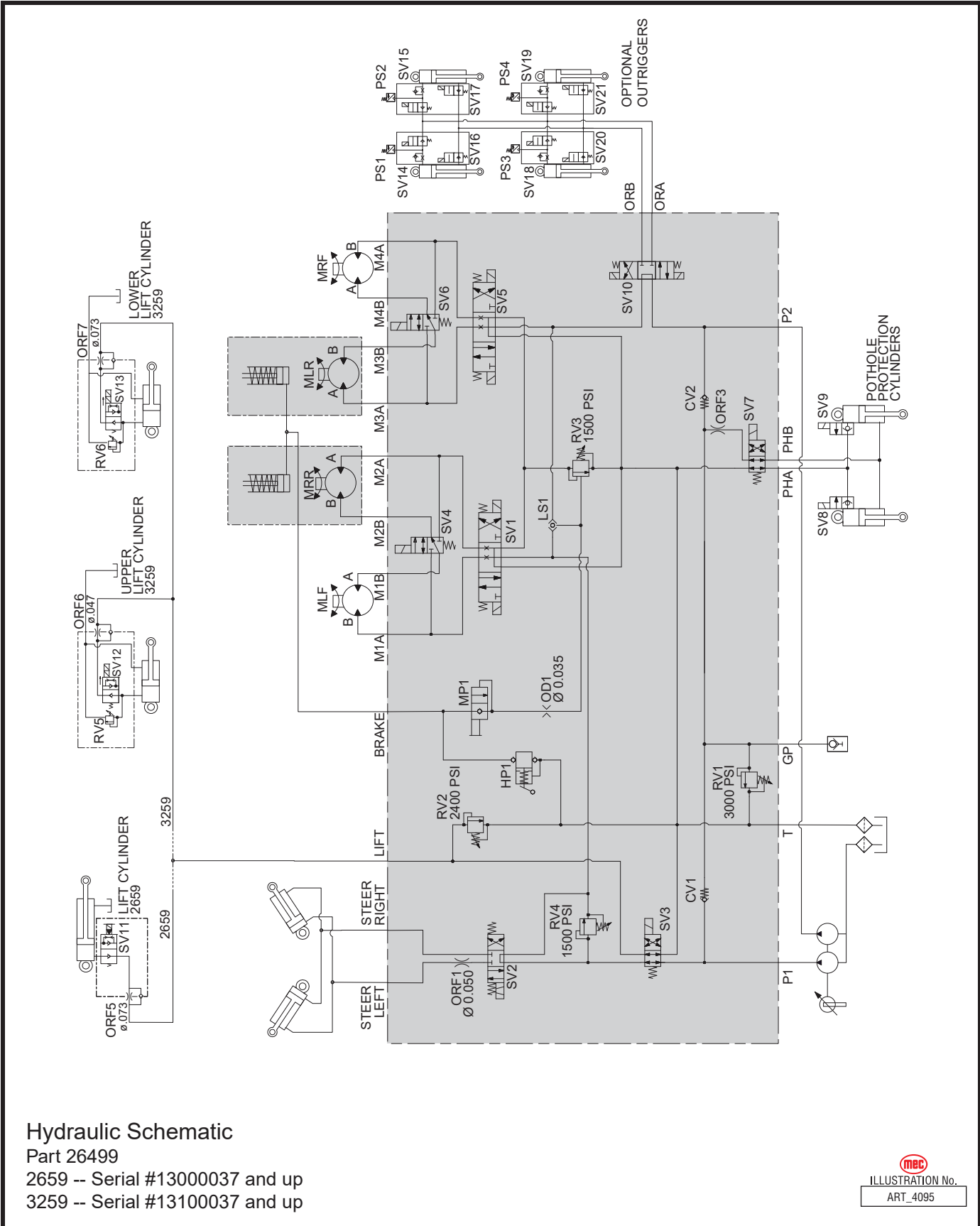

Hydraulic Schematic
 Part 26499
 2659 -- Serial #13000037 and up
 3259 -- Serial #13100037 and up

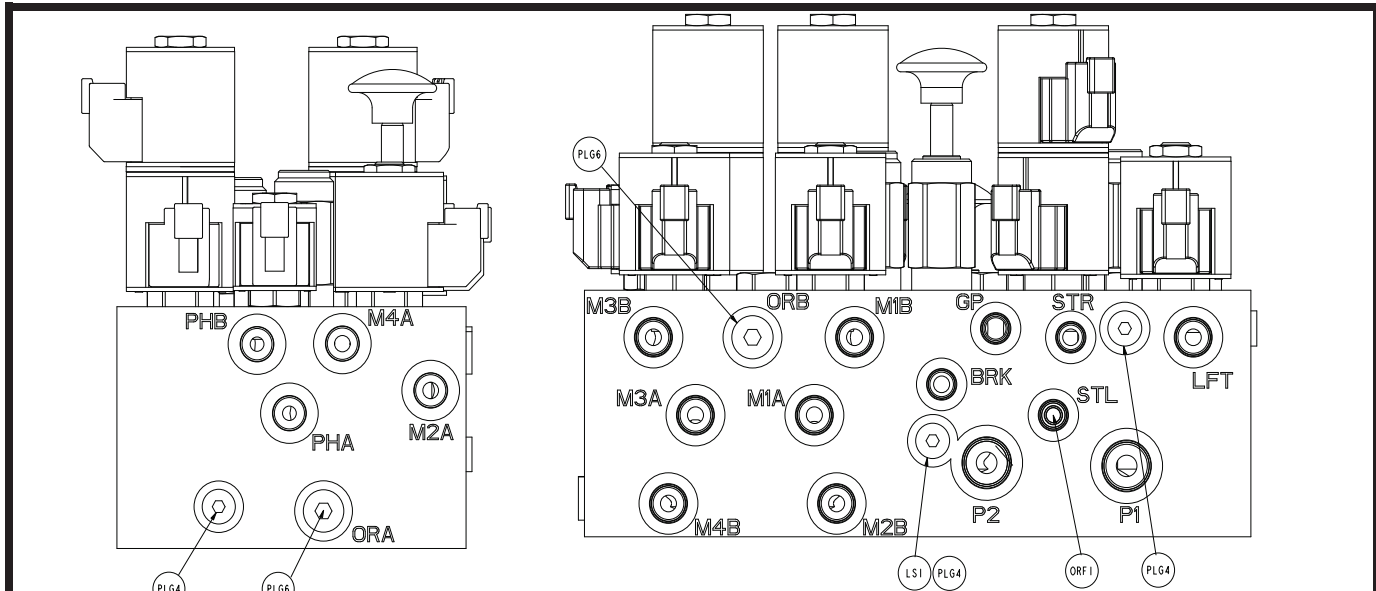
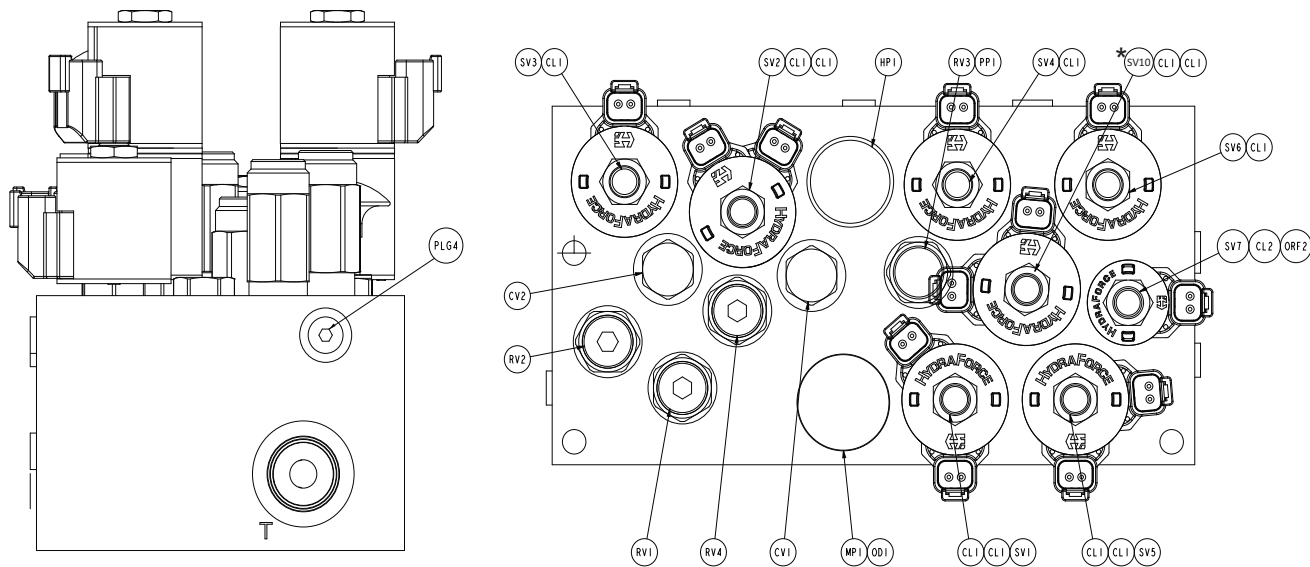

 ILLUSTRATION No.
 ART_4095

Figure 5-5: Functions Manifold, Later Machine



VALVE IDENTIFICATION

POS	FUNCTION	POS	FUNCTION
CV1	PUMP SEPARATION	RV4	RELIEF VALVE - STEER
CV2	PUMP SEPARATION	SV1	DRIVE VALVE LF & RR
HP1	EMR BRAKE REL PUMP	SV2	STEER VALVE
LS1	LOAD SHUTTLE - BRAKE	SV3	LIFT VALVE
MP1	EMR BRAKE REL VALVE	SV4	TORQUE VALVE
OD1	BRAKE REL ORIFICE	SV5	DRIVE VALVE RF & LR
ORF1	STEER SPEED ORIFICE	SV6	TORQUE VALVE
RV1	RELIEF VALVE - MAIN	SV7	POTHOLE DEP VALVE
RV2	RELIEF VALVE - LIFT	SV10	O/R DIRECTIONAL VALVE
RV3	COUNTERBALANCE VALVE		



* SV10 USED ON OUTRIGGER EQUIPPED MODELS ONLY
A CAVITY PLUG IS USED ON MODELS WITHOUT OUTRIGGERS

Function Manifold Valve Identification

Part 92784

2659 -- Serial #13000037 and up

3259 -- Serial #13100037 and up

MBC
ILLUSTRATION No.
ART_4096



NOTES:



ELECTRICAL SCHEMATICS -- EARLY MACHINES

Figure 5-6: Electrical Schematic -- Early Machines, 1 of 3

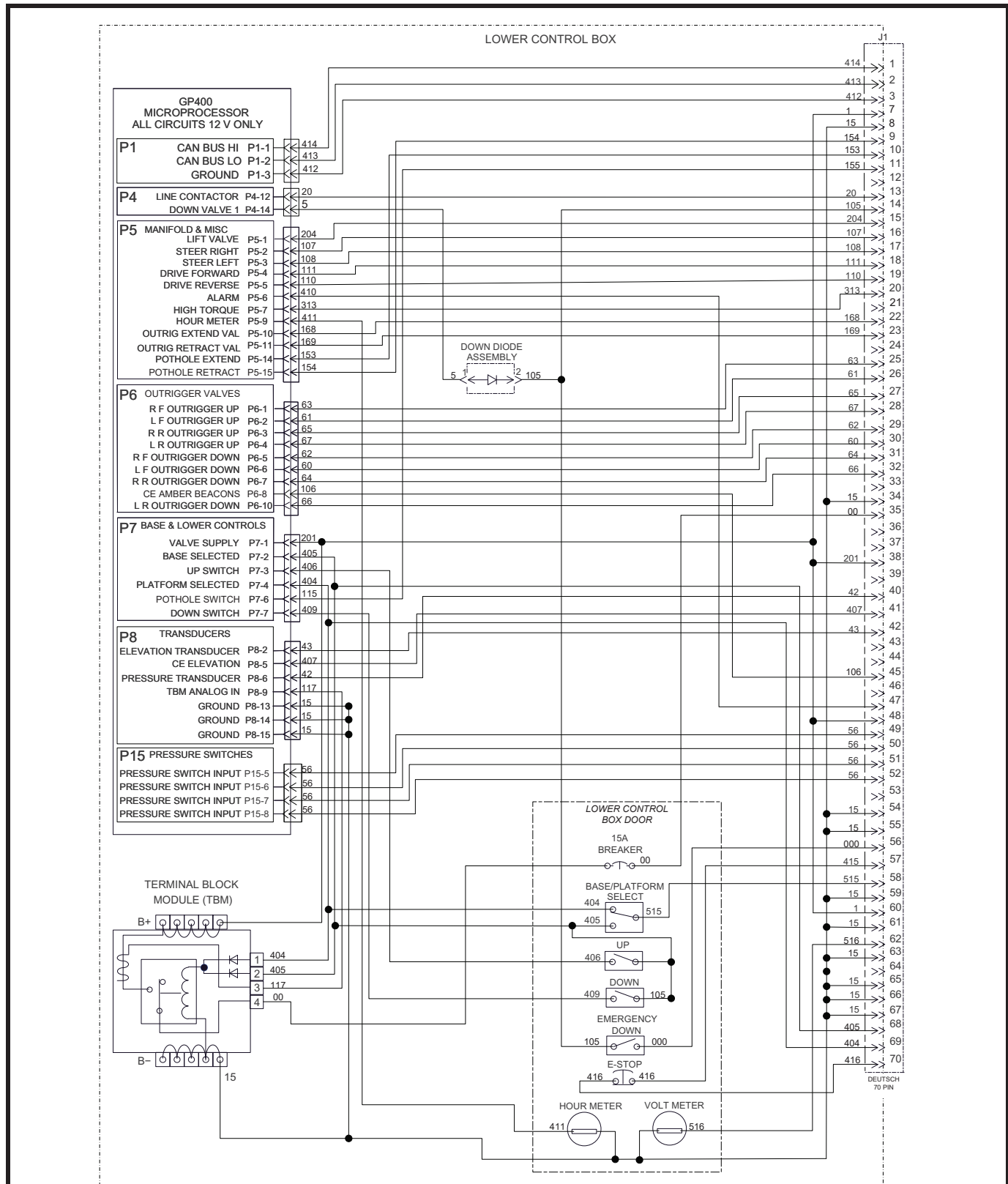

Electrical Schematic, 1 of 3
 Part #26090
 2659 -- up to Serial #1300036
 3259 -- up to Serial #1310036

 ILLUSTRATION No.
 ART_4088



Figure 5-7: Electrical Schematic -- Early Machines, 2 of 3

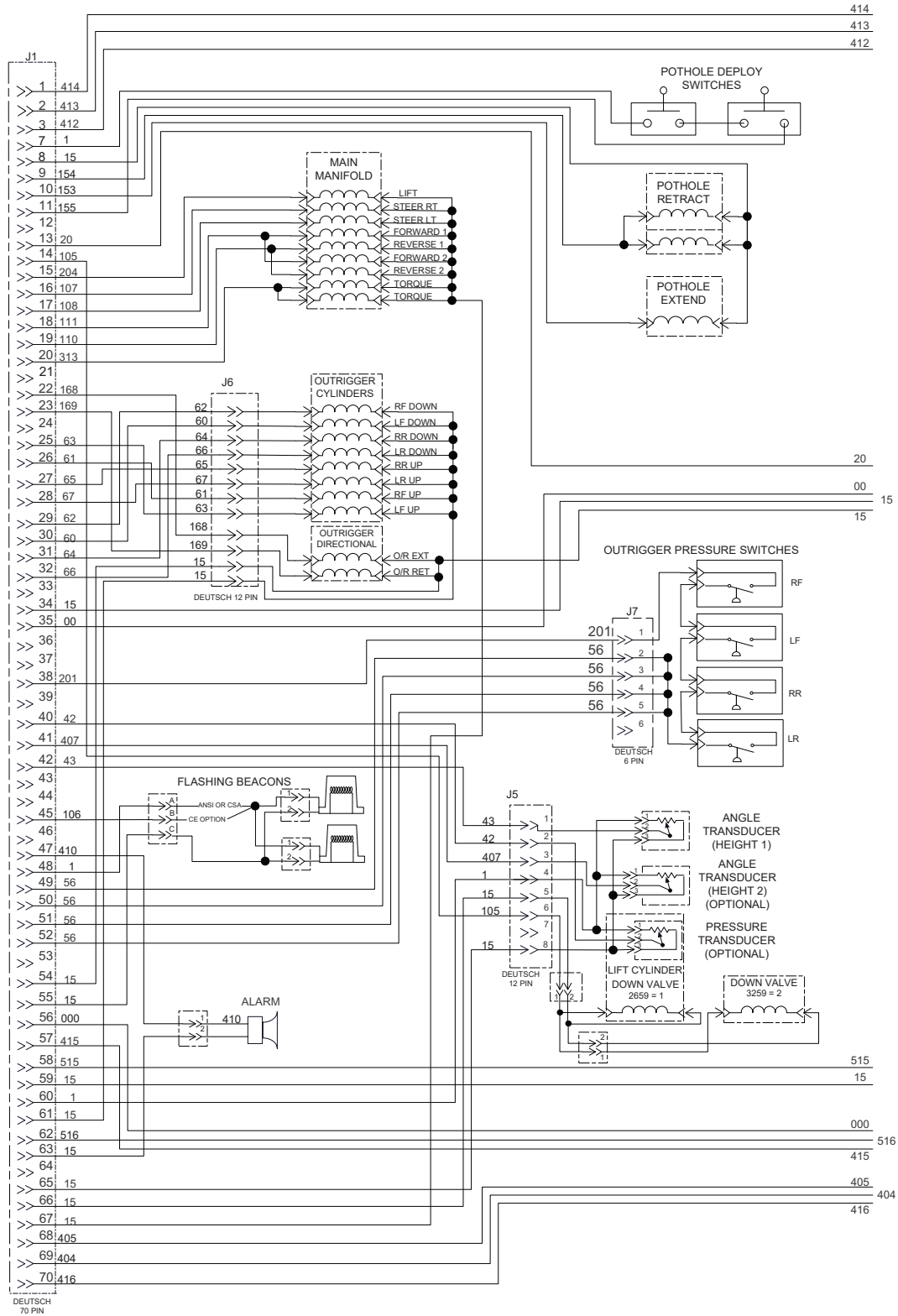

Electrical Schematic, 2 of 3

Part #26090

2659 -- up to Serial #13000036

3259 -- up to Serial #13100036

mec
ILLUSTRATION No.
ART_4089



Figure 5-8: Electrical Schematic -- Early Machines, 3 of 3

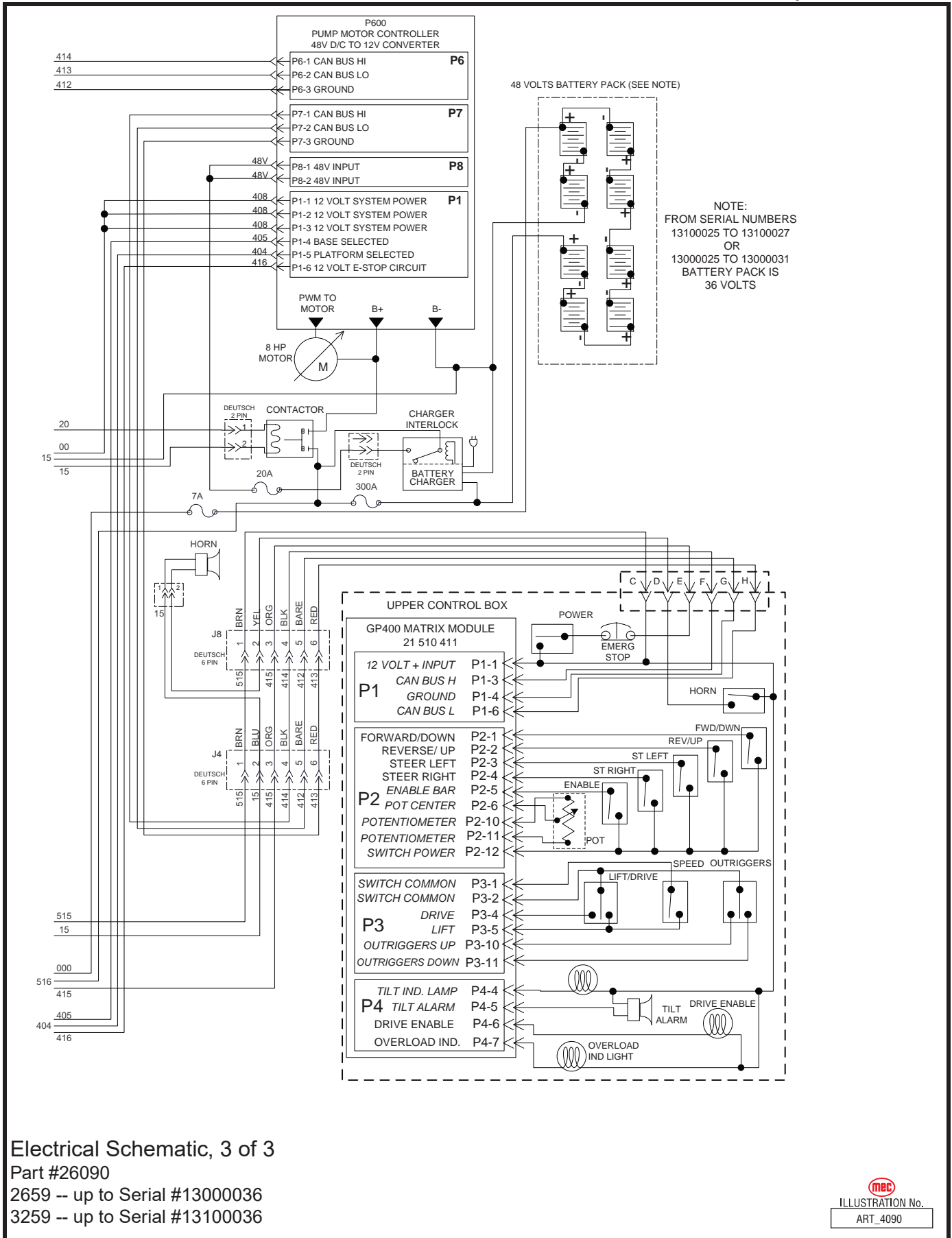

Electrical Schematic, 3 of 3

Part #26090

2659 -- up to Serial #13000036

3259 -- up to Serial #13100036

MEC
ILLUSTRATION No.
ART_4090



NOTES:



ELECTRICAL SCHEMATICS -- LATER MACHINES

Figure 5-9: Electrical Schematic -- Later Machines, 1 of 3

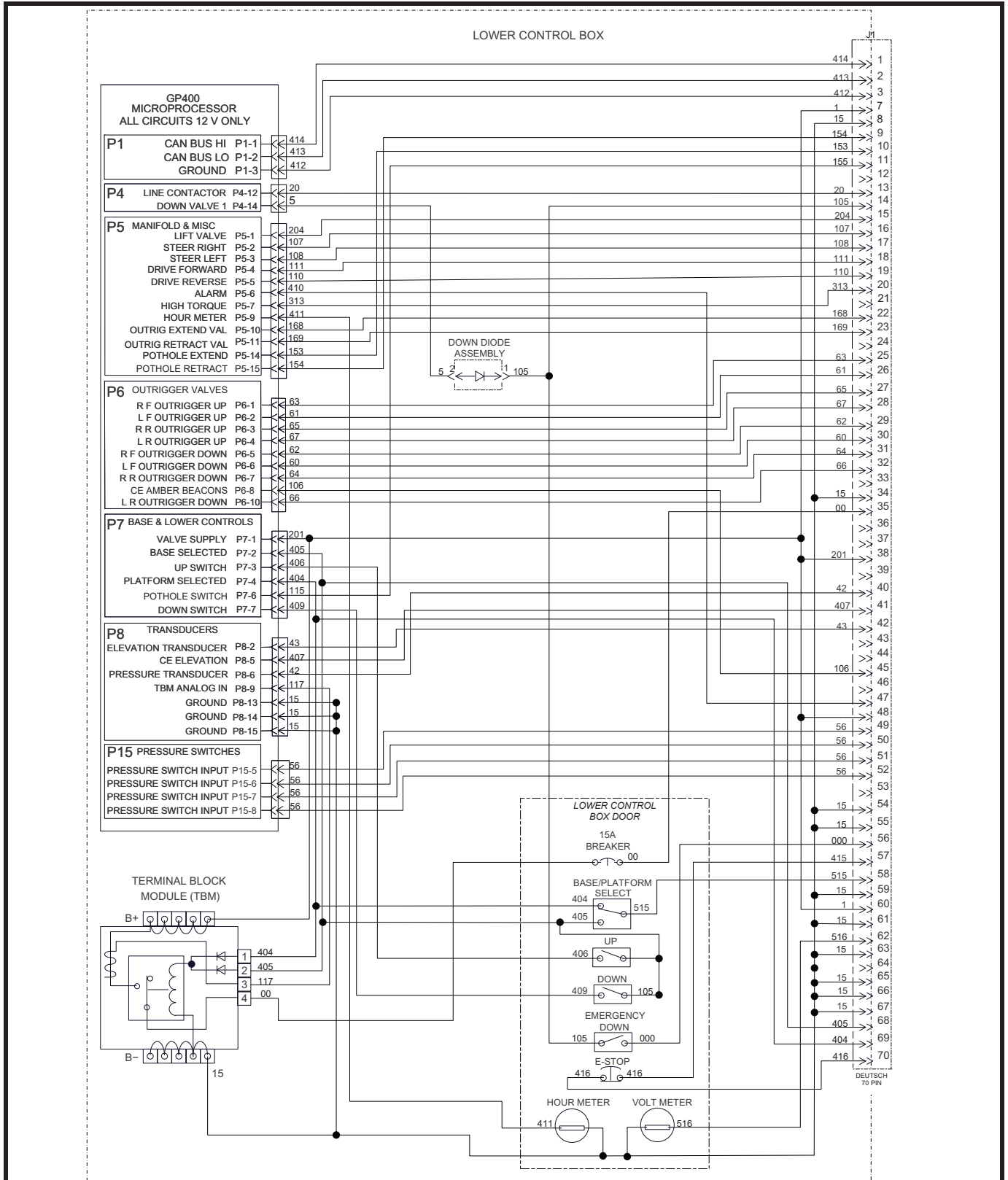

Electrical Schematic, 1 of 3
Part #26091
2659 -- Serial #13000037 and up
3259 -- Serial #13100037 and up

ILLUSTRATION No.
ART_4091



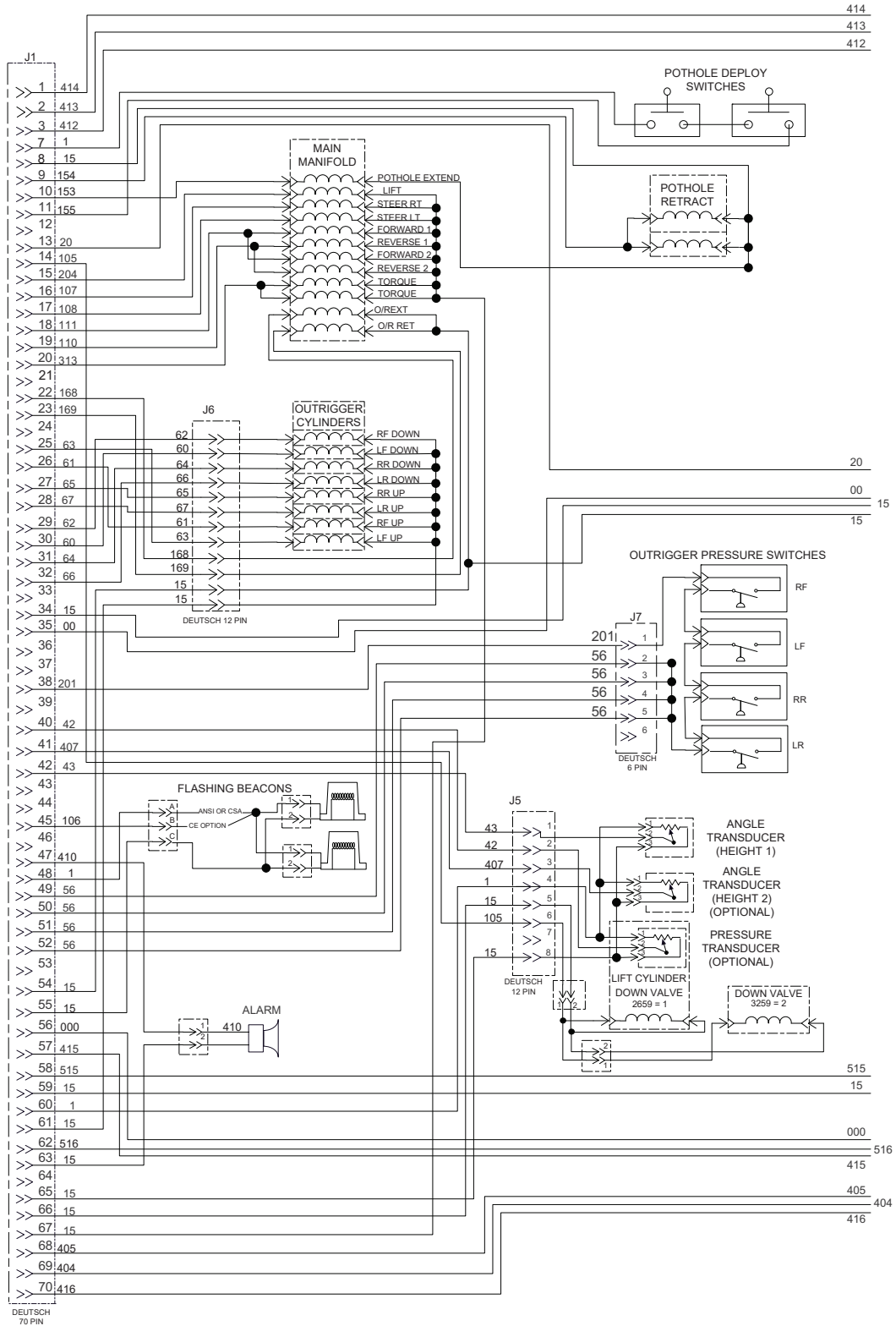

Electrical Schematic, 2 of 3
 Part #26091
 2659 -- Serial #1300037 and up
 3259 -- Serial #1310037 and up

mec
 ILLUSTRATION No.
 ART_4092



Figure 5-11: Electrical Schematic -- Later Machines, 3 of 3

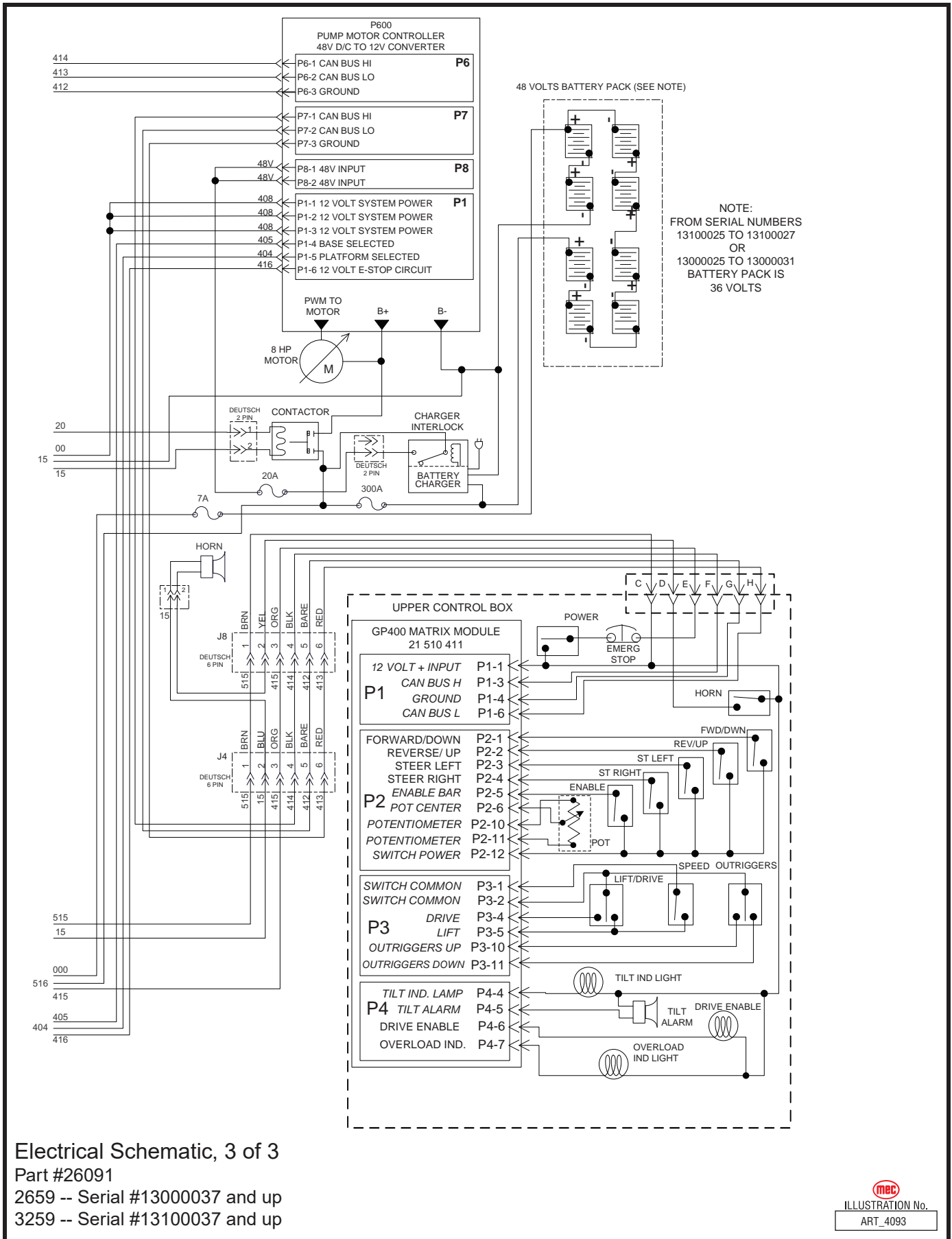

Electrical Schematic, 3 of 3
 Part #26091
 2659 -- Serial #13000037 and up
 3259 -- Serial #13100037 and up

MEC
 ILLUSTRATION No.
 ART_4093



CONTROLS

Figure 5-12: Lower Controls

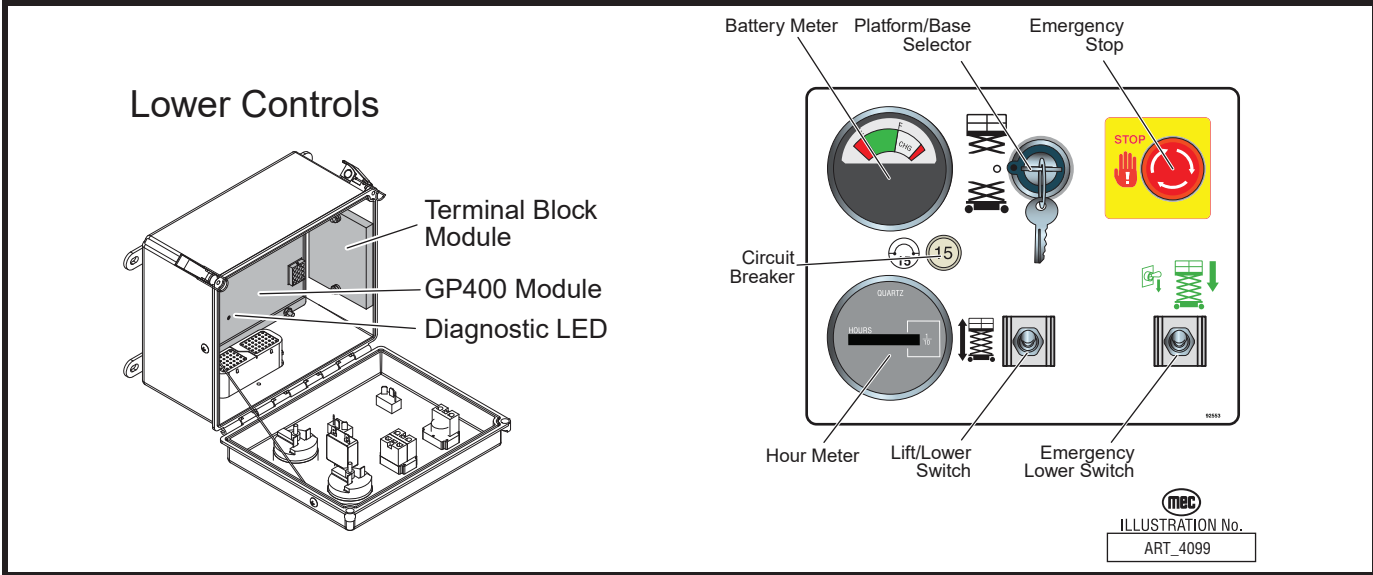

Figure 5-13: Upper Controls

