

CONTROLS AND SWITCHES

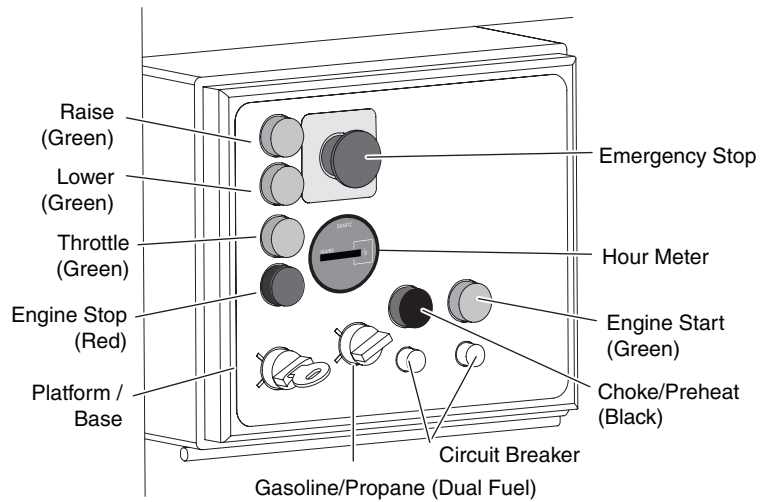
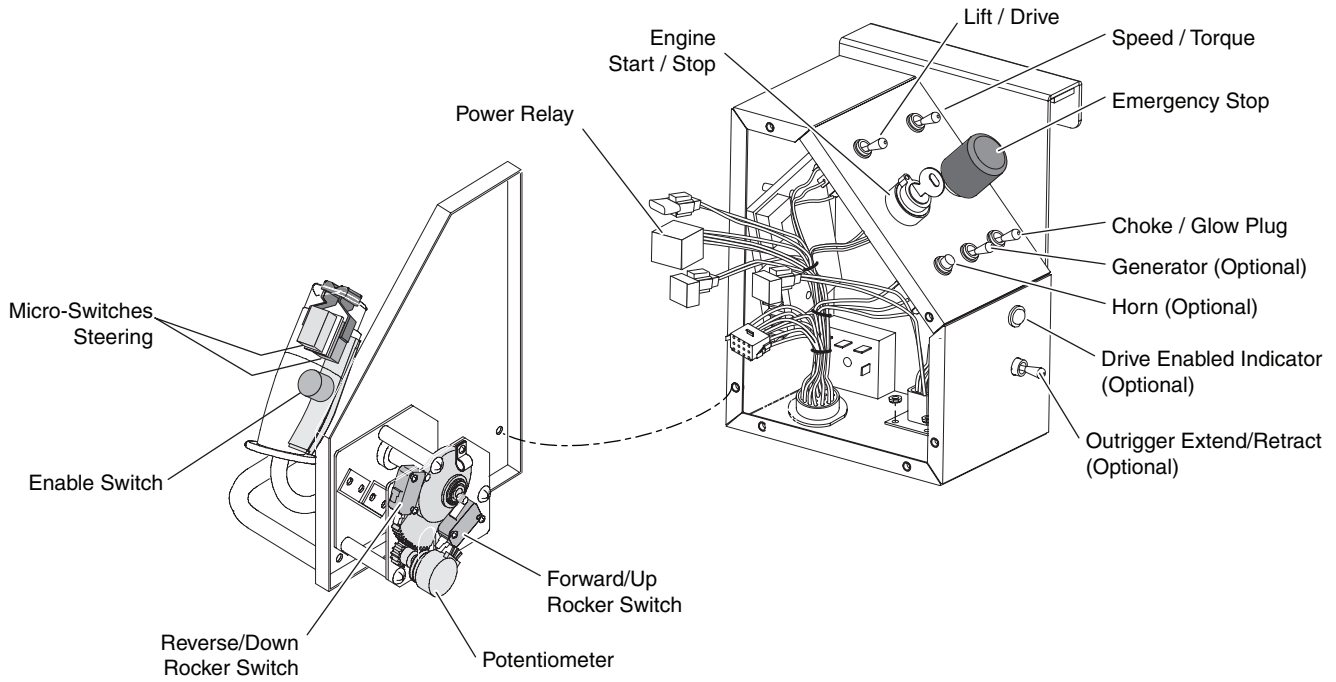



ILLUSTRATION No.
ART_2075



SECTION 5: SCHEMATICS

Hydraulic Schematic	5-2
Main Hydraulic Manifold	5-4
Optional Outriggers	5-5
Electric Schematics	5-6
Wire Harness Connections	5-6
Main Wiring Harness	5-7
Circuit Board Schematic	5-8
Upper Controls	5-10
Upper Controls - With Outriggers	5-11
Lower Control Box	5-12
Diesel Engine	5-13
Dual Fuel Engine	5-14
Optional Outriggers	5-15
Optional Generator	5-16



HYDRAULIC SCHEMATIC

Callout	Description
	Lift Cylinder Components (2591RT/3391RT)
CYL2	Cylinder
MA3	Manifold, Lift Cylinder
SV5	Solenoid Valve - 12V Cable Attach
ORF3	Orifice - 0.093
	Lift Cylinder Components (4191RT)
CYL3	Cylinder, Upper
MA5	Manifold, Lift Cylinder, Upper
SV6	Solenoid Valve - 12V Dual Coil
RV4	Relief Valve - 3200 PSI
ORF4	Orifice - 0.093
CYL4	Cylinder, Lower
MA4	Manifold, Lift Cylinder, Lower
SV6	Solenoid Valve - 12V Dual Coil
RV4	Relief Valve - 3200 PSI
ORF6	Orifice - 0.047
	Wheel Motor Components
LF	Wheel Motor - Dual Displacement (Left Front)
LR	Wheel Motor - Dual Displacement (Left Rear)
RF	Wheel Motor - Dual Displacement (Right Front)
RR	Wheel Motor - Dual Displacement (Right Rear)
	Pump
P1	Pump - Variable Displacement Pressure Compensated
	Filters
FL1	Return Filter - 10 Micron
	Cylinders
CYL1	Cylinder, Steering
	Oscillating Axle Components
CYL6	Axle Lock Cylinder
SV10	Solenoid Valve, Poppet N.C.
	Optional Outriggers Components
MA6	Manifold, Outriggers
CV1 - CV2	Check Valve
CYL5	Outrigger Cylinder
SV7	Solenoid Valve, Poppet N.C.
SV8	Solenoid Valve, Poppet N.C.
SV9	Spool Valve, 4-way - 3-Position

Callout	Description
	Main Manifold Components
MA1	Manifold, Main Valve Block
SVD1	Spool Valve, Drive, 4 Way - 3 Position
SV1	Spool Valve, Lift, 3 Way
SV2	Spool Valve, Steer, 4 Way - 3 Position
SV3	Spool Valve, Series Parallel, 4 Way - 2 Position
SV4	Spool Valve, High Speed, 3 Way - 2 Position
SP1	Proportional Valve - 12V
RV1	Relief Valve, Lift - 2500 PSI
RV2	Relief Valve, Steer - 1500 PSI
RV3	Relief Valve, Front Drive Motors - 2800 PSI
RV4	Relief Valve, Rear Drive Motors - 2800 PSI
PD1 - PD2	Piloted Spool Valve, 4 Way - 3 Position
EP1 - EP2 - EP3	Piloted Poppet Valve, Flow Divider Bypass
LS1 - LS2 - LS3	Load Sense Shuttle Check Valve
CBV1 - CBV2	Counter Balance Valve
CL1	Coil, Series 8 - 12V
CL2	Coil, Series 10 - 12V
CL3	Coil, Series 10 E-Coil - 12V
FD1 - FD2	Flow Divider / Combiner
EC1	Pressure Compensator
CV1 - CV2	Check Valve, Load Sense
CV3 - CV7	Check Valve, Anti Cavitation
CV8	Check Valve, Tank Return
OPL5	Orifice Plug, Brake - 0.035
OPL1	Orifice Plug, Steer - 0.080
OPL2 - OPL3	Orifice Plug, Flow Divider Bleed - 0.040
OPL4	Orifice Plug, Compensator Bleed - 0.093

NOTE: Outrigger Option connects from -
Main Manifold ports ORLS, ORR and ORS
- to -
Outrigger Manifold ports ORLS, ORR and ORS
(Outrigger schematic shown separately)

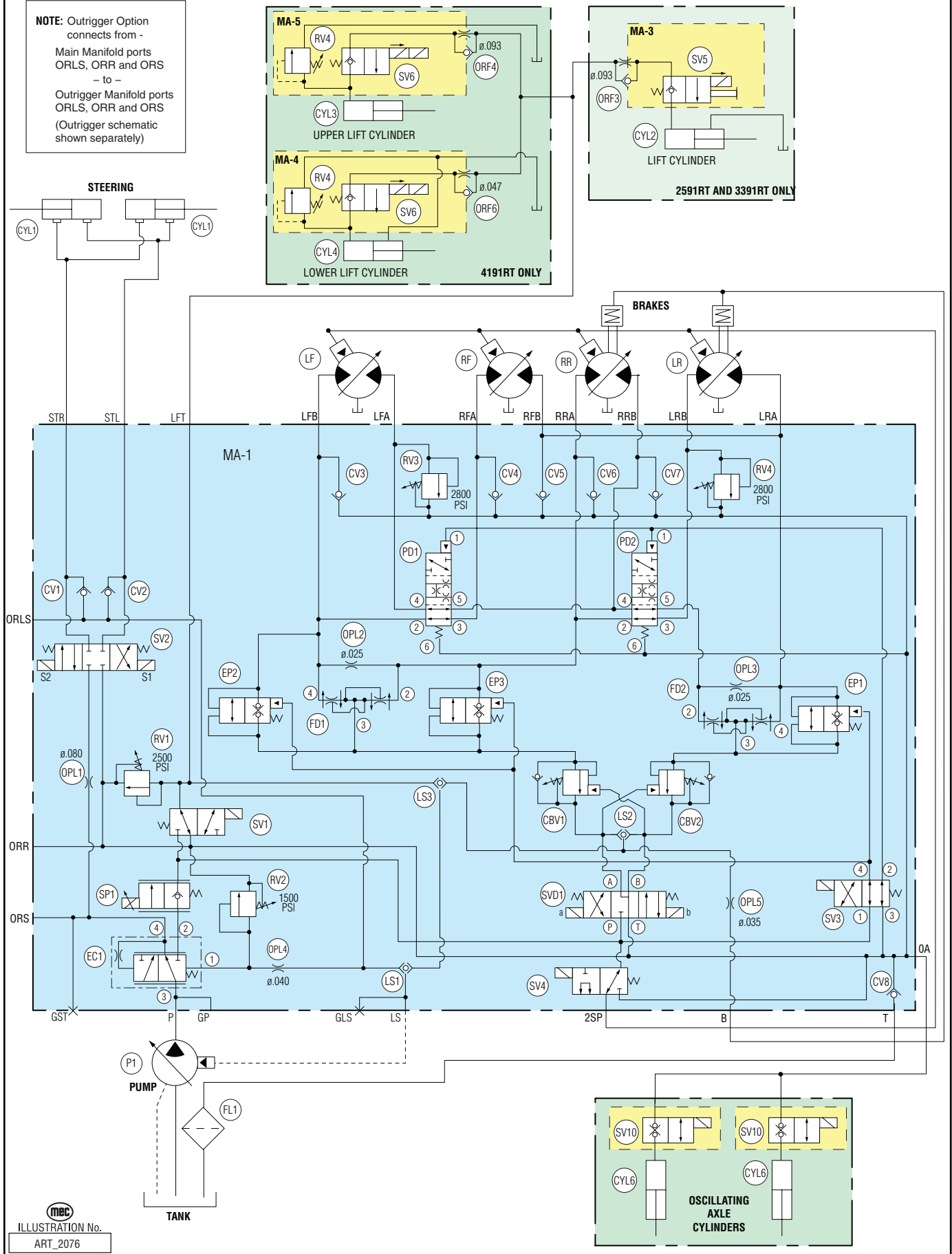

MEC
ILLUSTRATION No.
ART_2076



Main Hydraulic Manifold

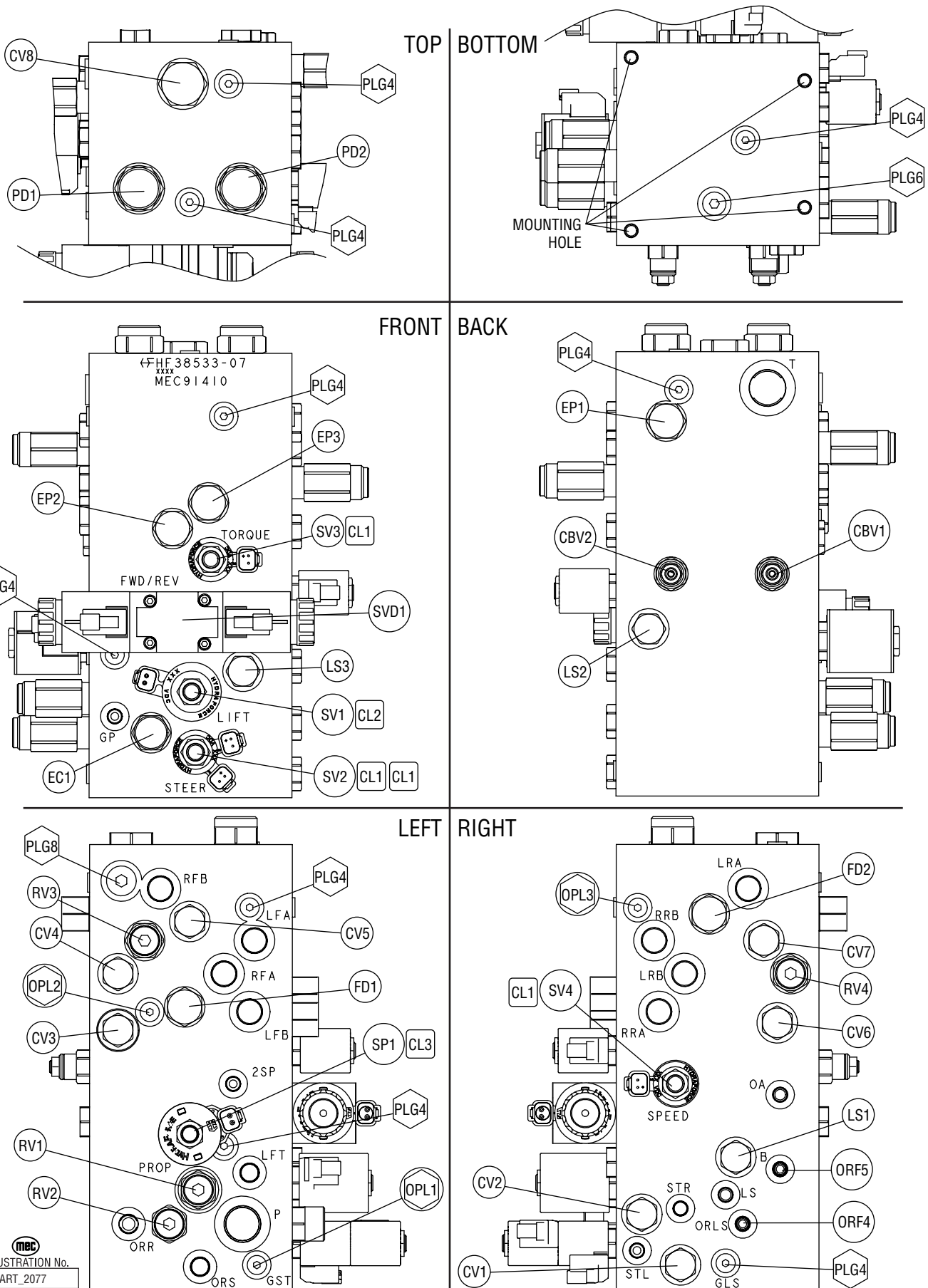

mec
ILLUSTRATION No.
ART_2077



Optional Outriggers

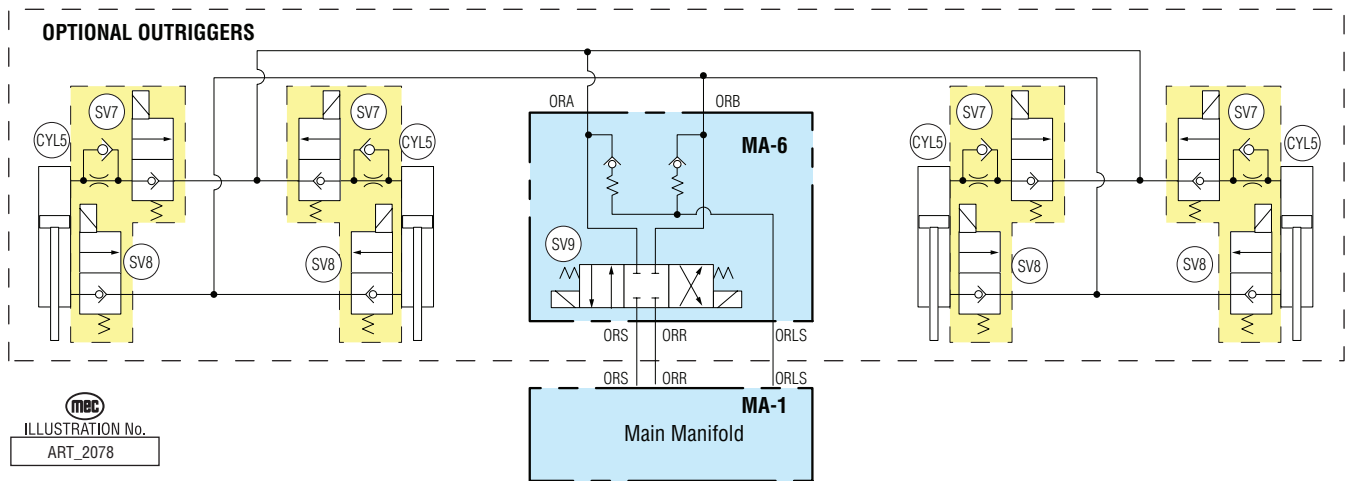
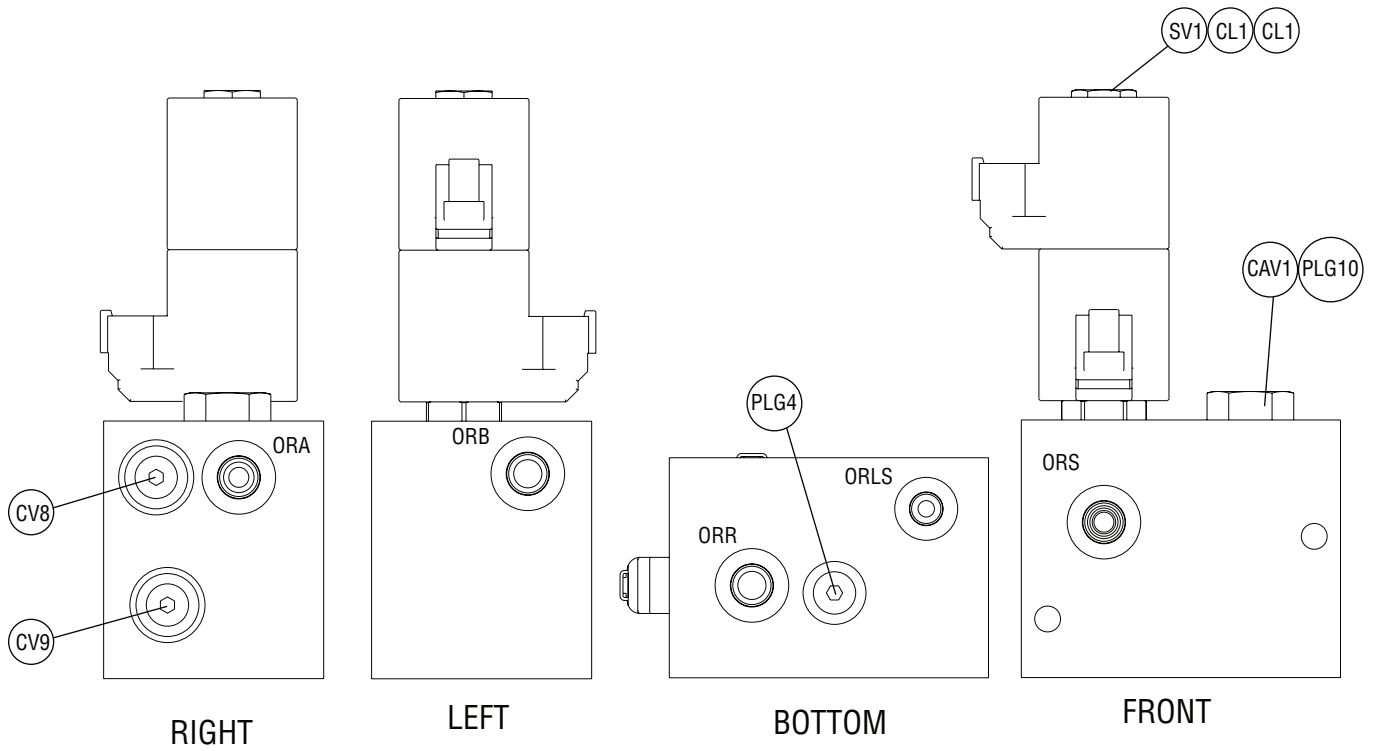

ELECTRIC SCHEMATICS

Wire Harness Connections

Located on the circuit board in the lower control box.

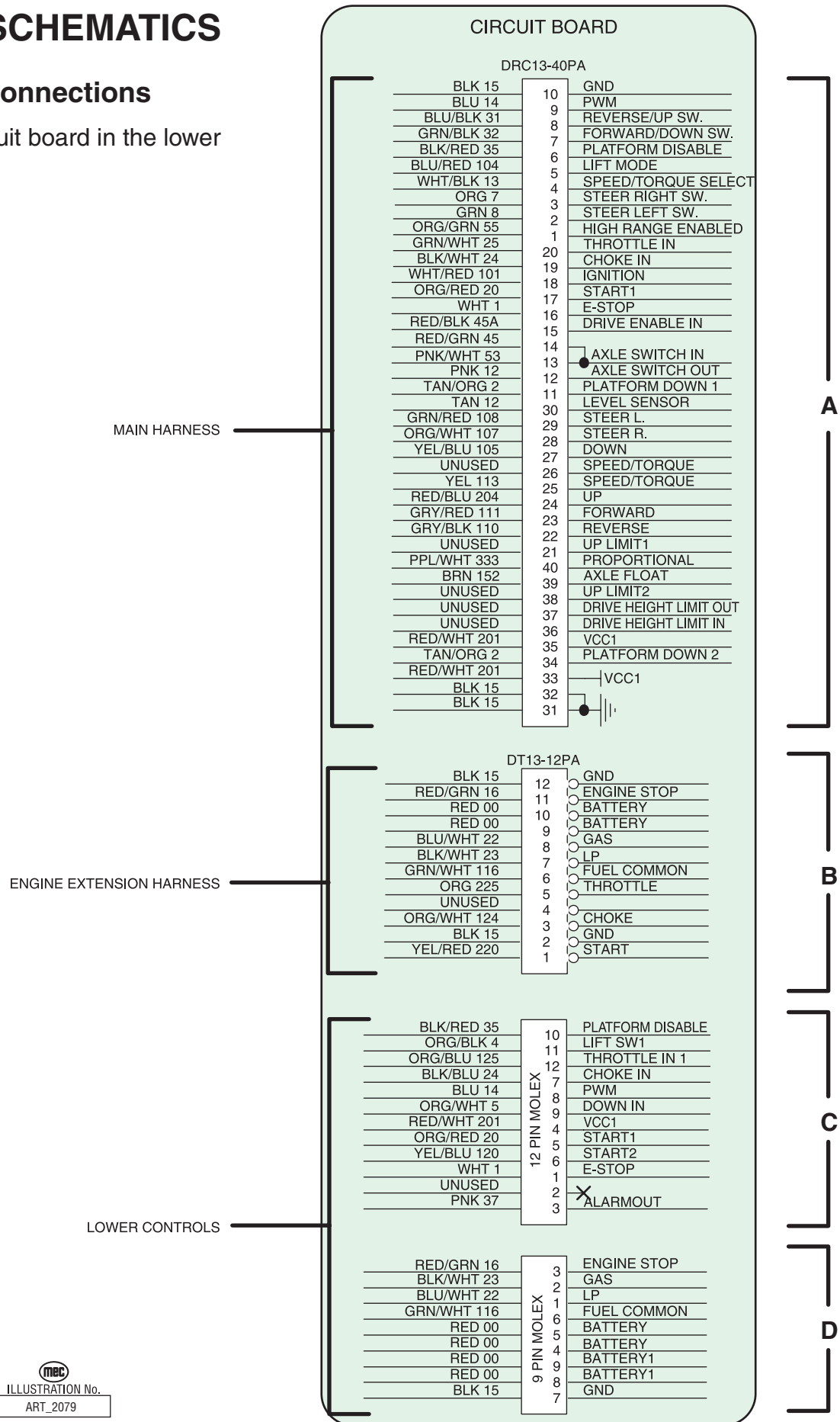
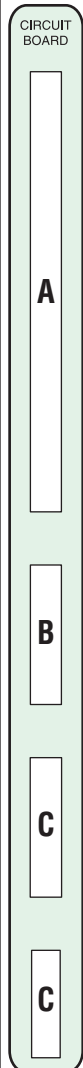

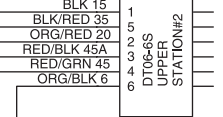
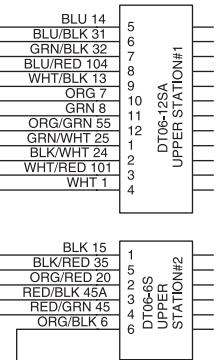

ILLUSTRATION No.
ART_2079

Main Wiring Harness

MAIN HARNESS - ANSI



- A**
- 10 BLK 15
 - 9 BLU 14
 - 8 BLU/BLK 31
 - 7 GRN/BLK 32
 - 6 BLK/RED 35
 - 5 BLU/RED 104
 - 4 WHT/BLK 13
 - 3 ORG 7
 - 2 GRN 8
 - 1 ORG/GRN 55
 - 20 GRN/WHT 25
 - 19 BLK/WHT 24
 - 18 WHT/RED 101
 - 17 ORG/RED 20
 - 16 WHT 1
 - 15 RED/BLK 45A
 - 14 RED/GRN 45
 - 13 PNK/WHT 52
 - 12 PNK 53
 - 11 TAN/ORG 2
 - 10 TAN 12
 - 9 GRN/RED 108
 - 28 ORG/WHT 107
 - 27 YEL/BLU 105
 - 26 UNUSED
 - 25 YEL 113
 - 24 RED/BLU 204
 - 23 GRY/RED 111
 - 22 GRY/BLK 110
 - 21 UNUSED
 - 40 PPL/WHT 333
 - 39 BRN 152
 - 38 UNUSED
 - 37 UNUSED
 - 36 UNUSED
 - 35 RED/WHT 201
 - 34 TAN/ORG 2
 - 33 RED/WHT 201
 - 32 BLK 15
 - 31 BLK 15



CABLE TO PLATFORM

VALVE BLOCK

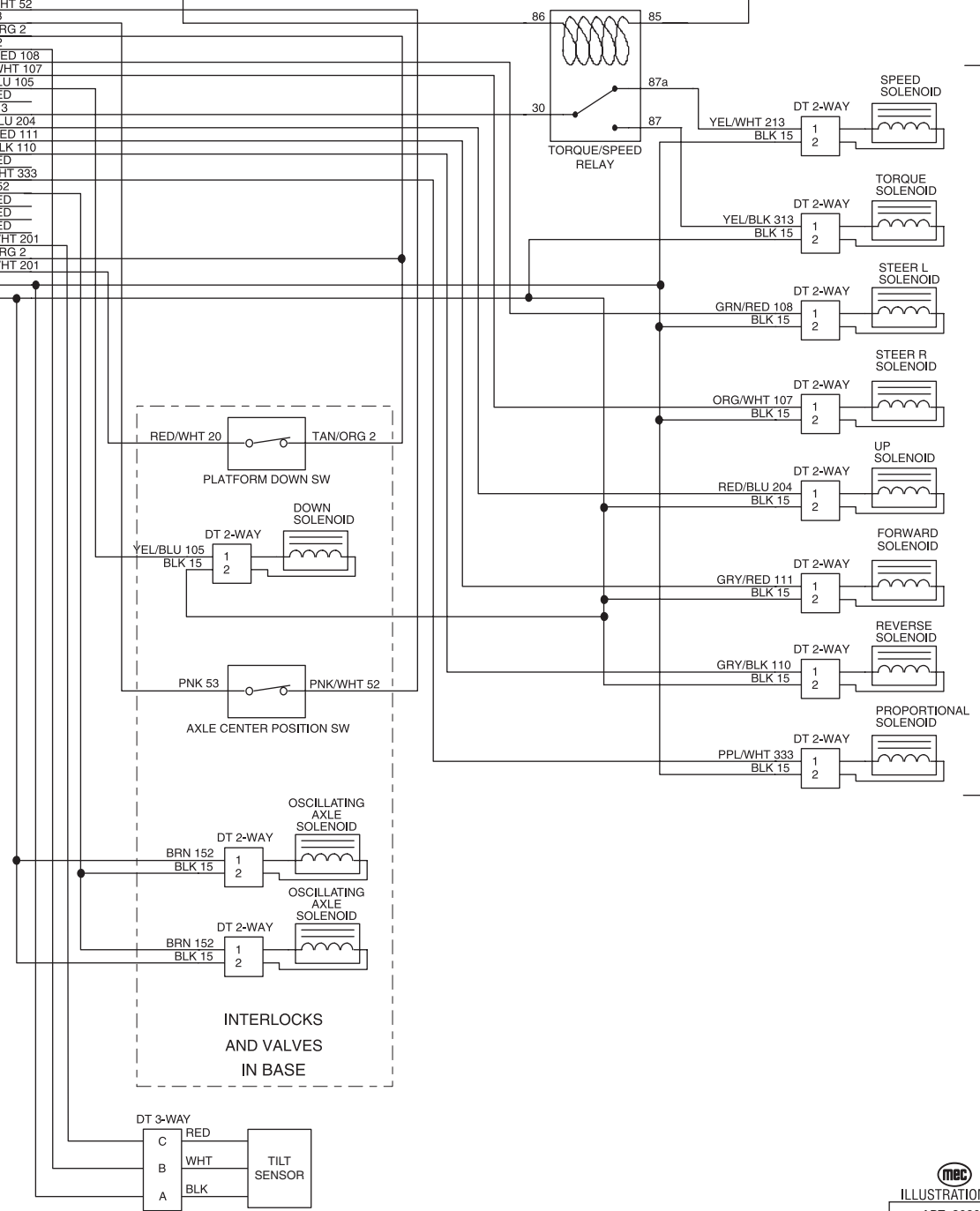

mec
ILLUSTRATION No.
ART_2080



Circuit Board Schematic

The Circuit Board schematic is broken into two pages for clarity. The cable connections are shown on this page. Match the numbers to line-up the traces.

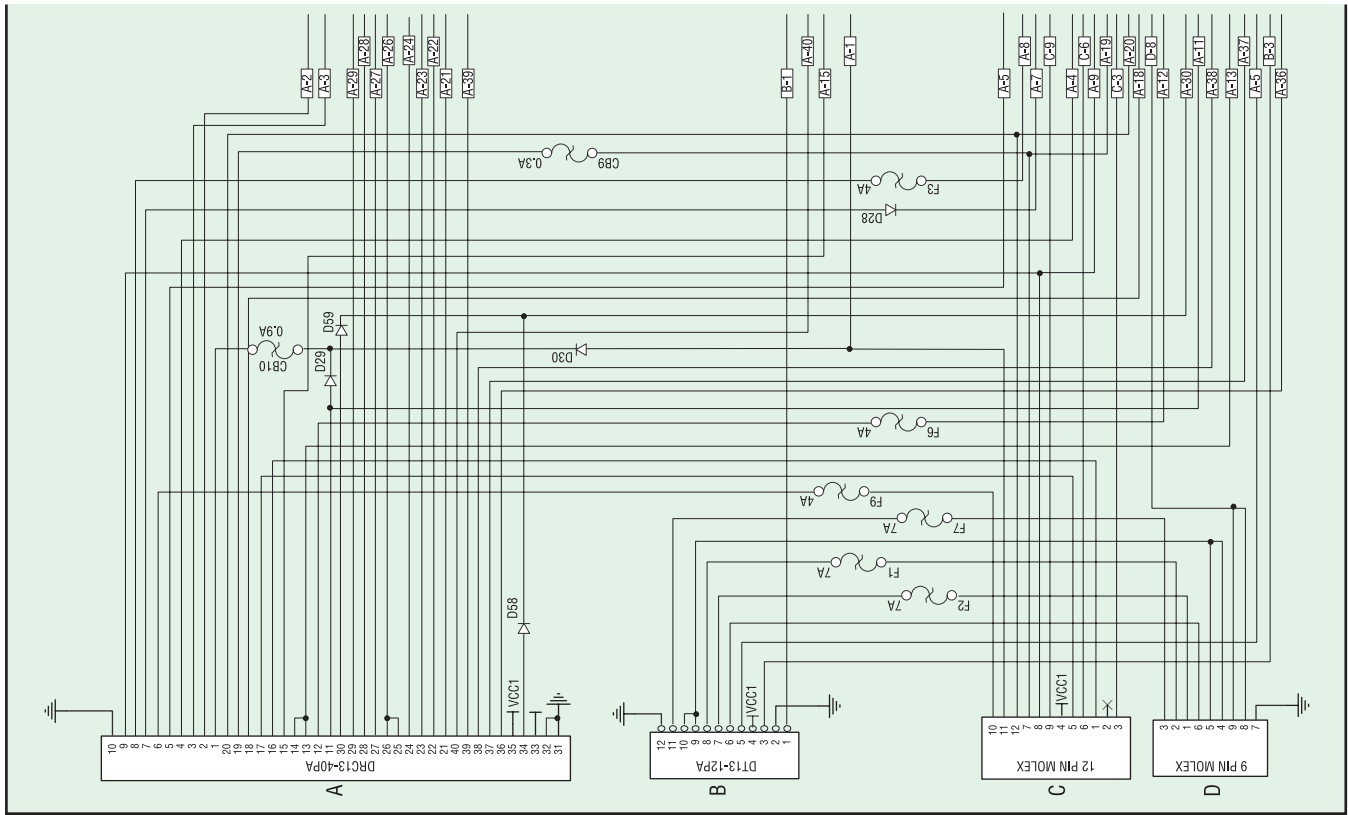

mecc
ILLUSTRATION No.
ART_2081

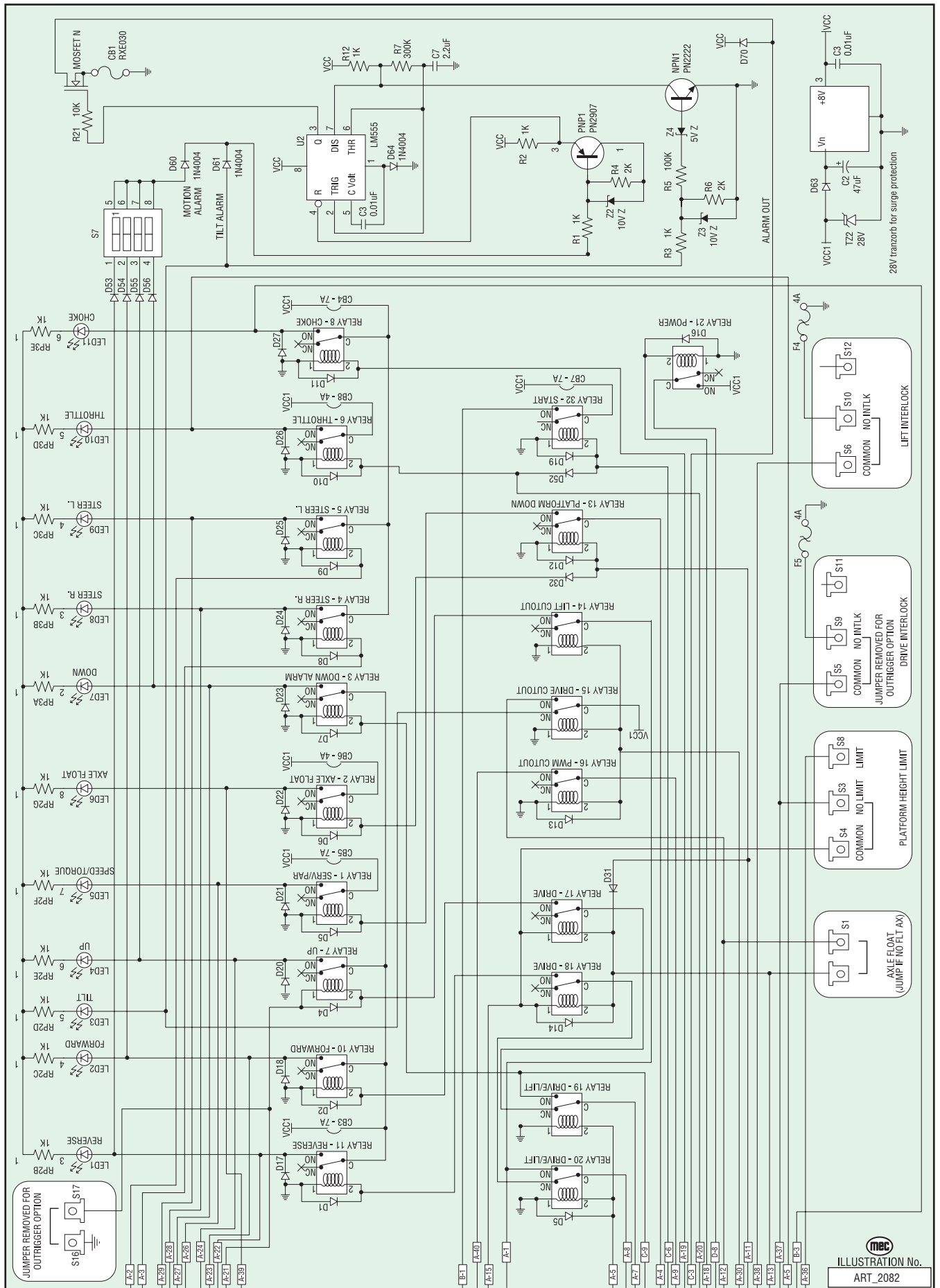
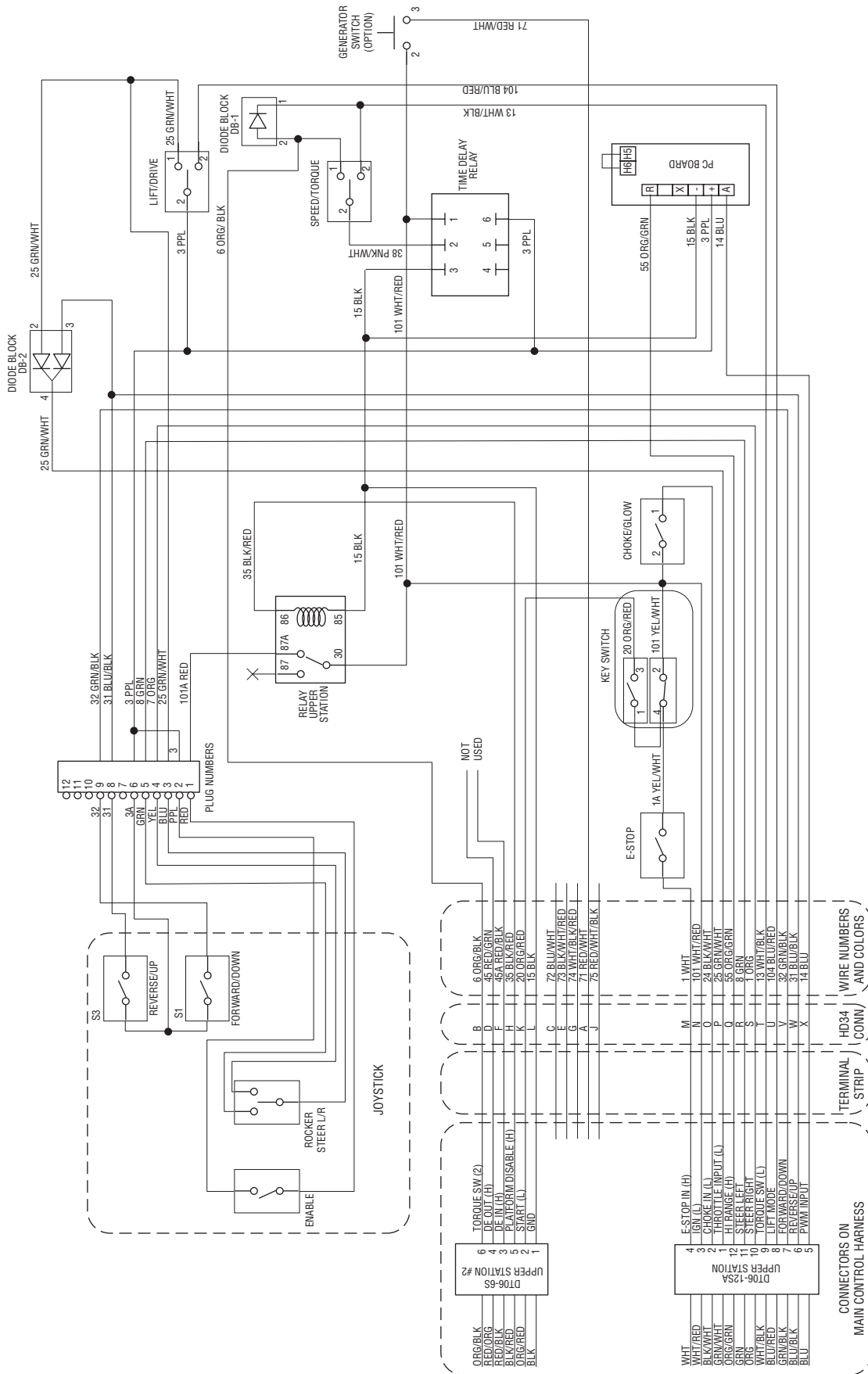

ILLUSTRATION No.
ART_2082



Upper Controls

ANSI UPPER CONTROLS WITHOUT OUTRIGGER OPTION



MEC
ILLUSTRATION No.
ART_2083



Upper Controls - With Outriggers

ANSI UPPER CONTROLS WITH OUTRIGGER OPTION

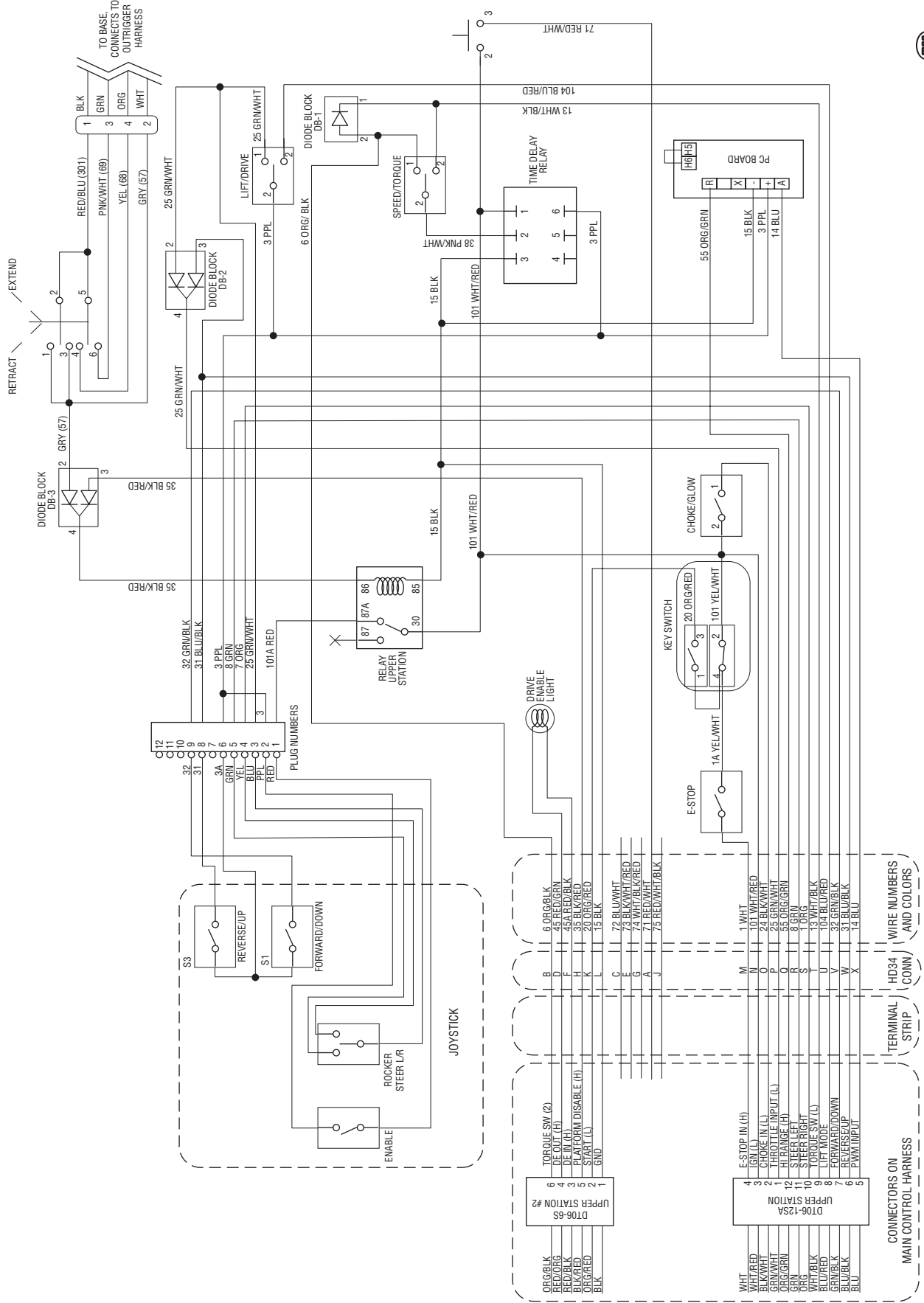
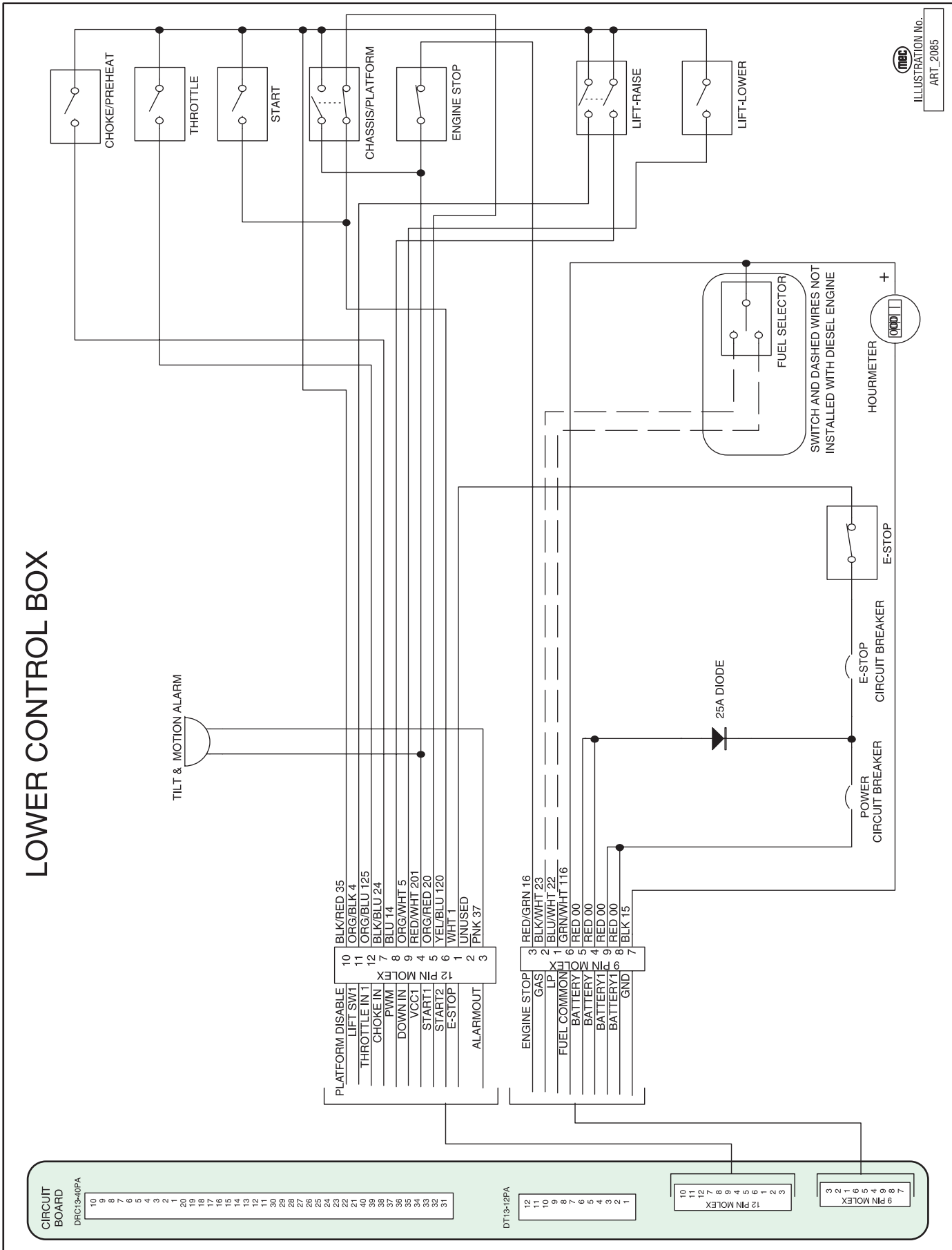

ILLUSTRATION No.
ART_2084



Lower Control Box



Diesel Engine

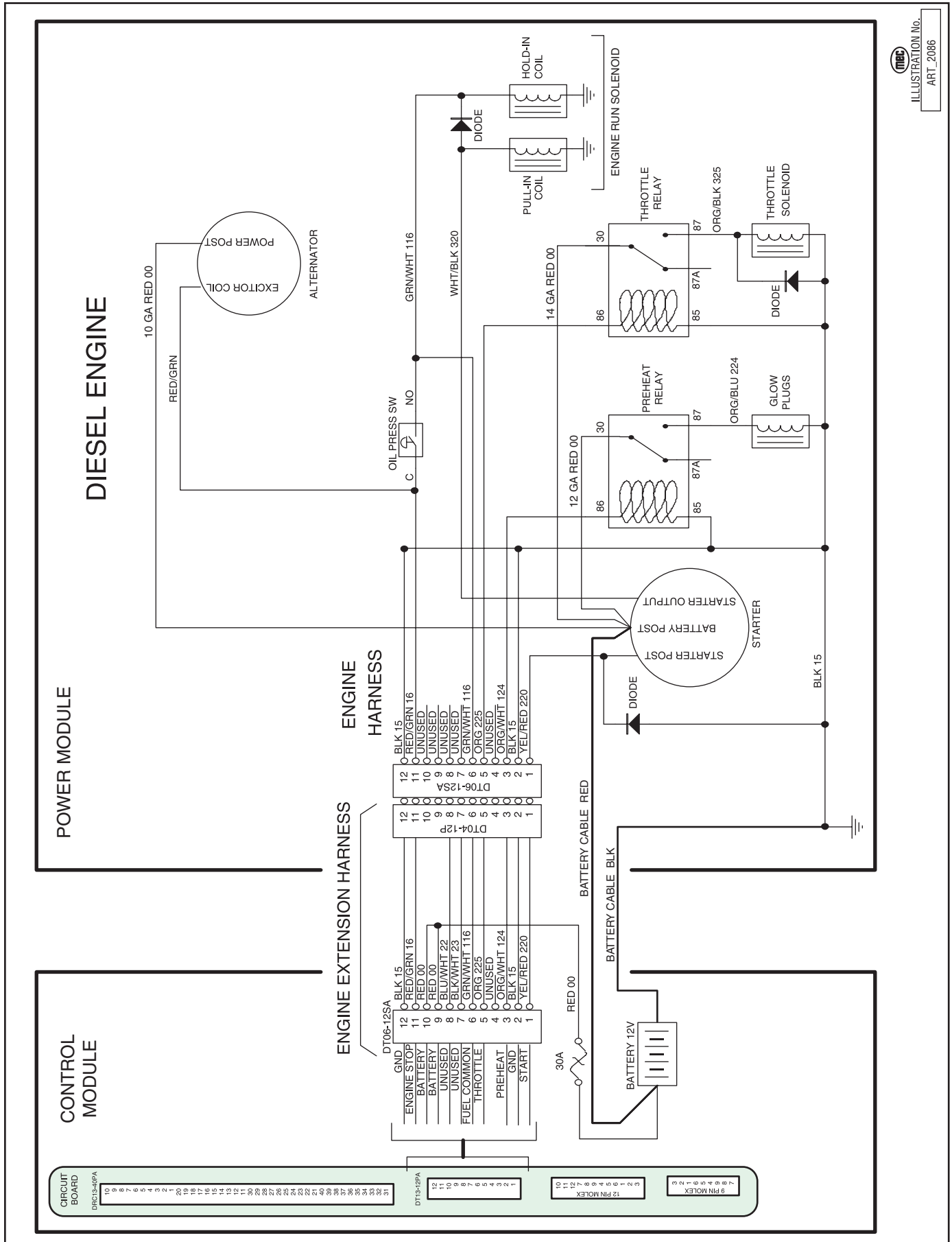

ILLUSTRATION NO.
ART_2086



Dual Fuel Engine

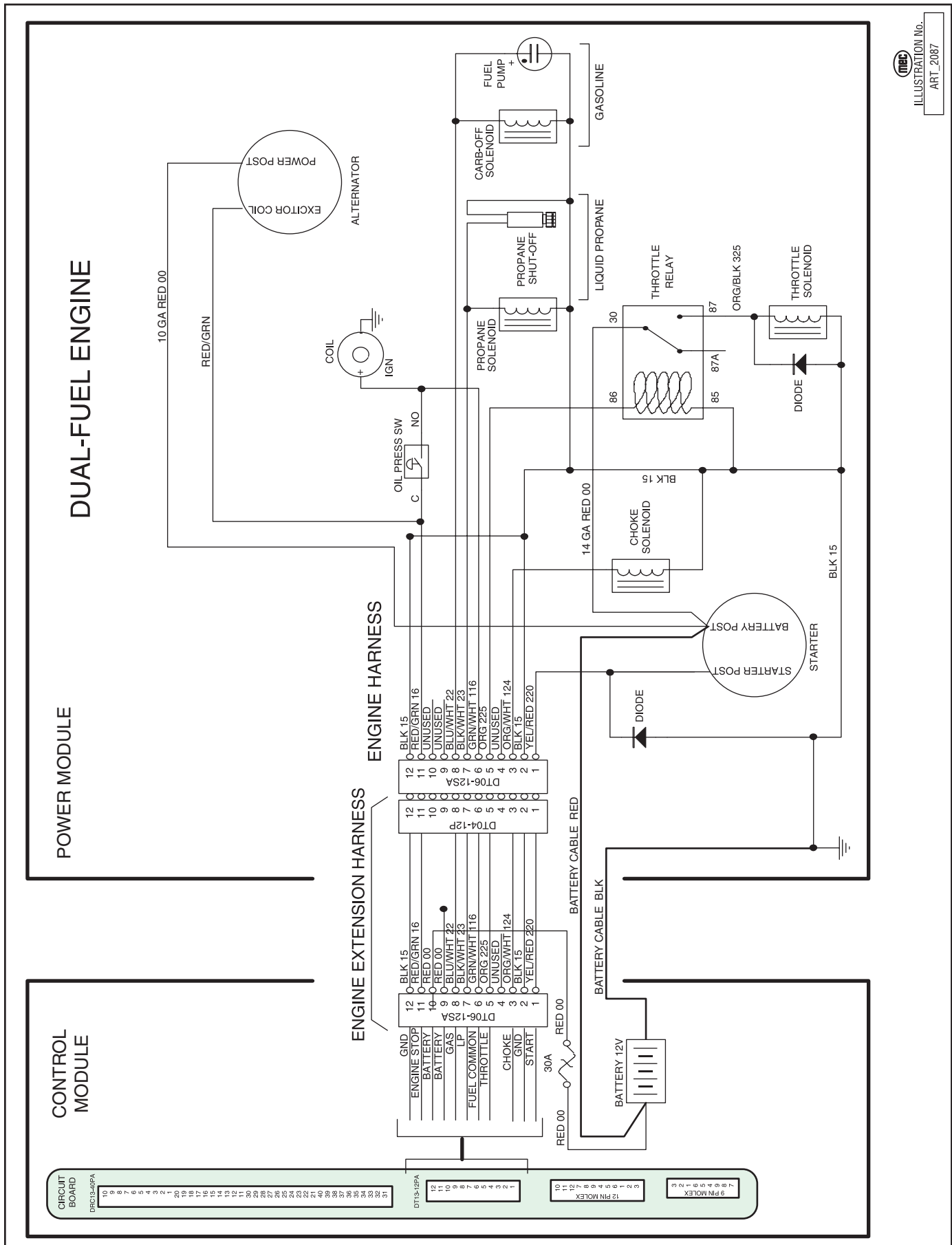
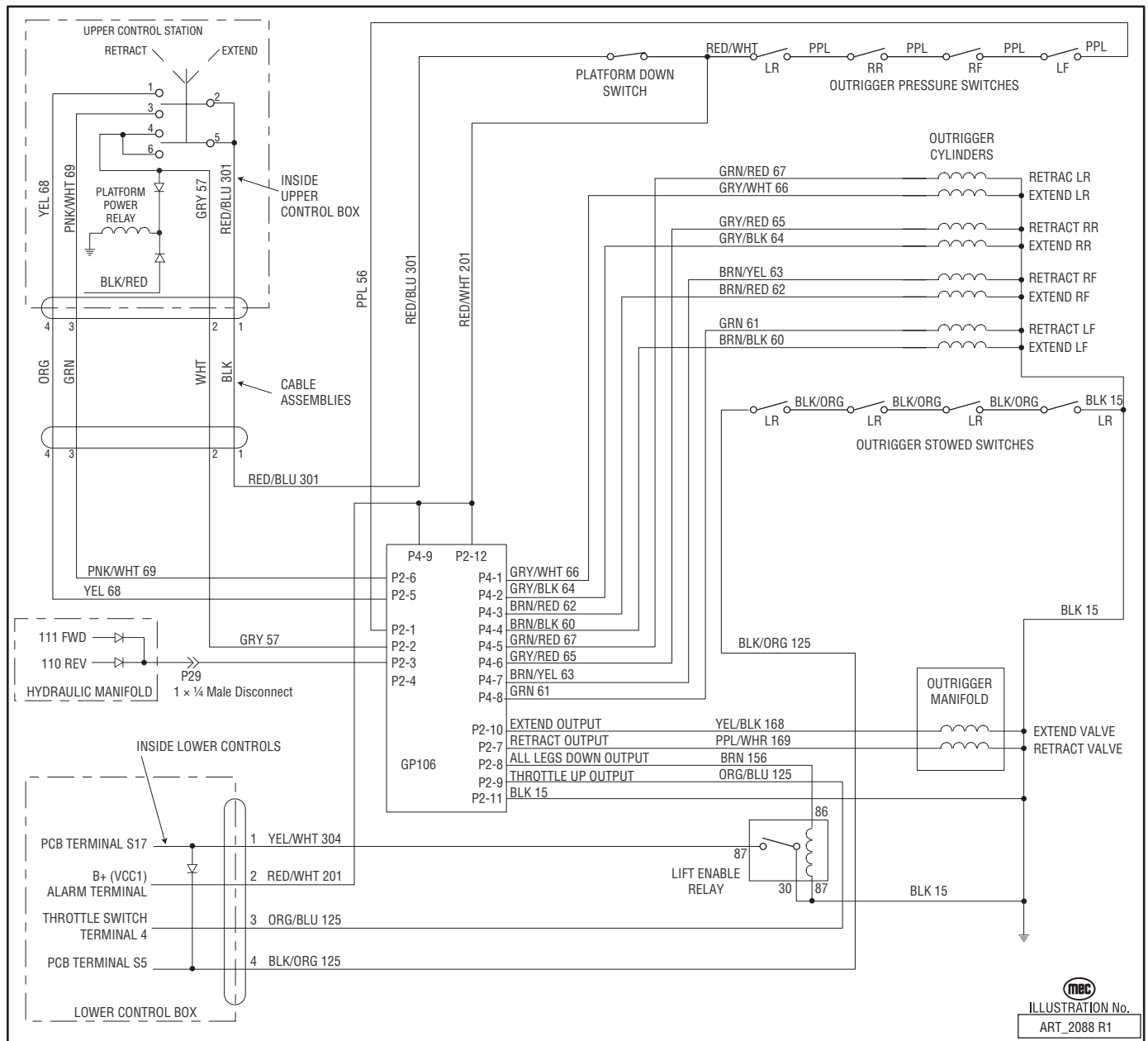

ILLUSTRATION NO. ART. 2087



Optional Outriggers



Optional Generator

