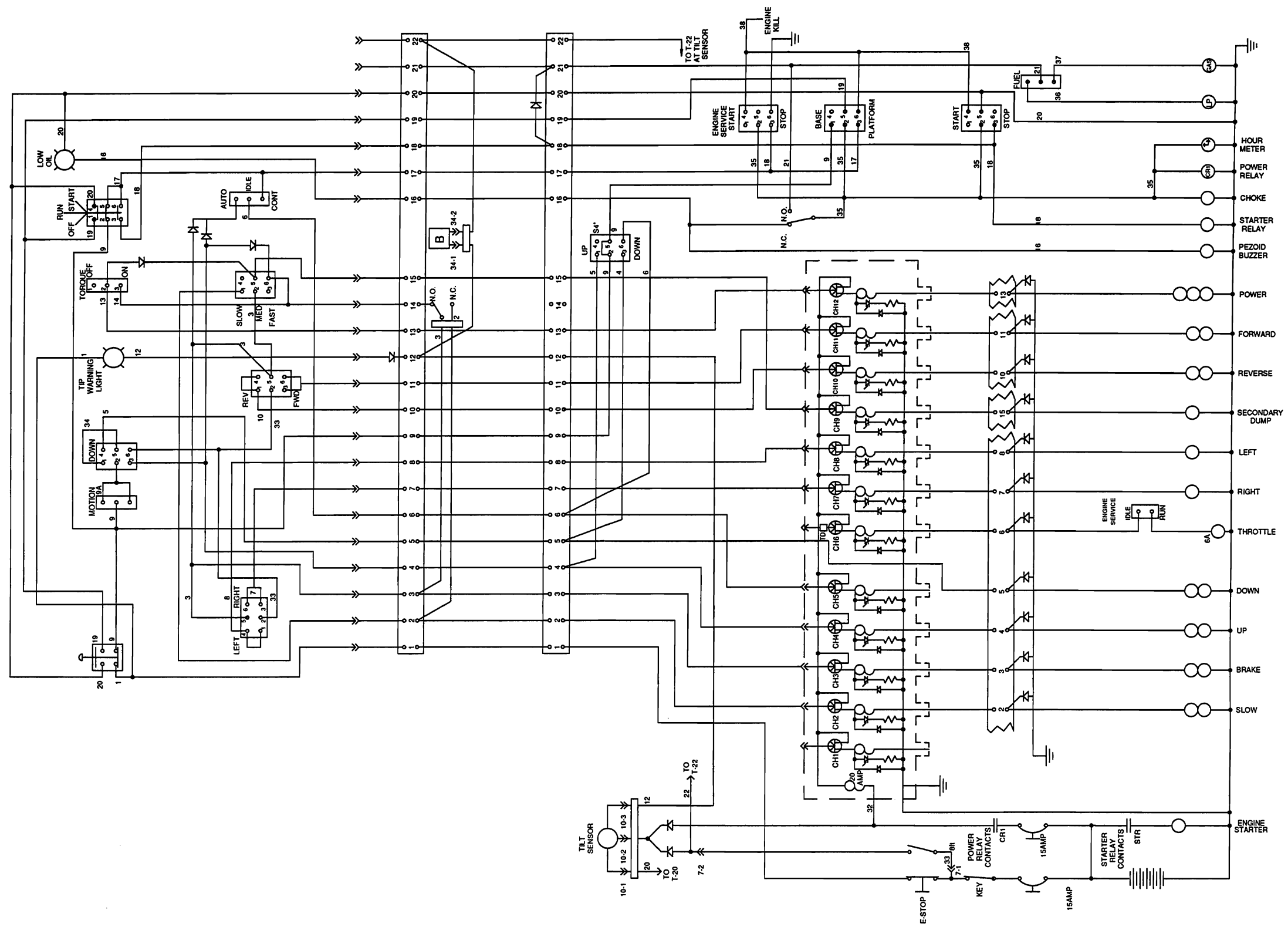
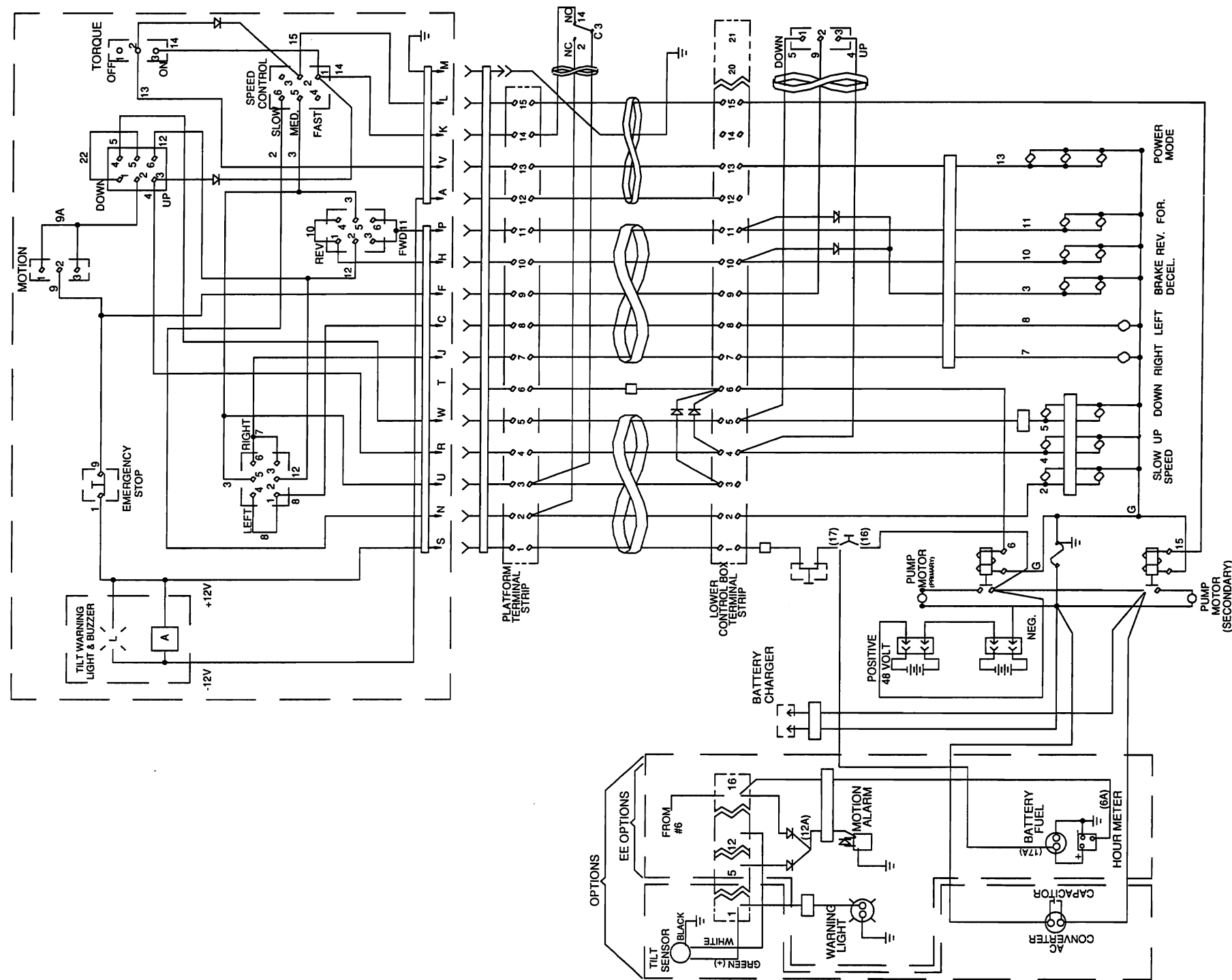

Figure 5-1. Quadrex 25SRT/33SRT
Dual Fuel Electrical Schematic



ART190

Figure 5-2. Quadrex 25E/33E Electrical Schematic - Standard Upper Control Box



ART303

Figure 5-3. Quadrex 25E/33E Electrical Schematic - Optional Joystick Upper Control Box

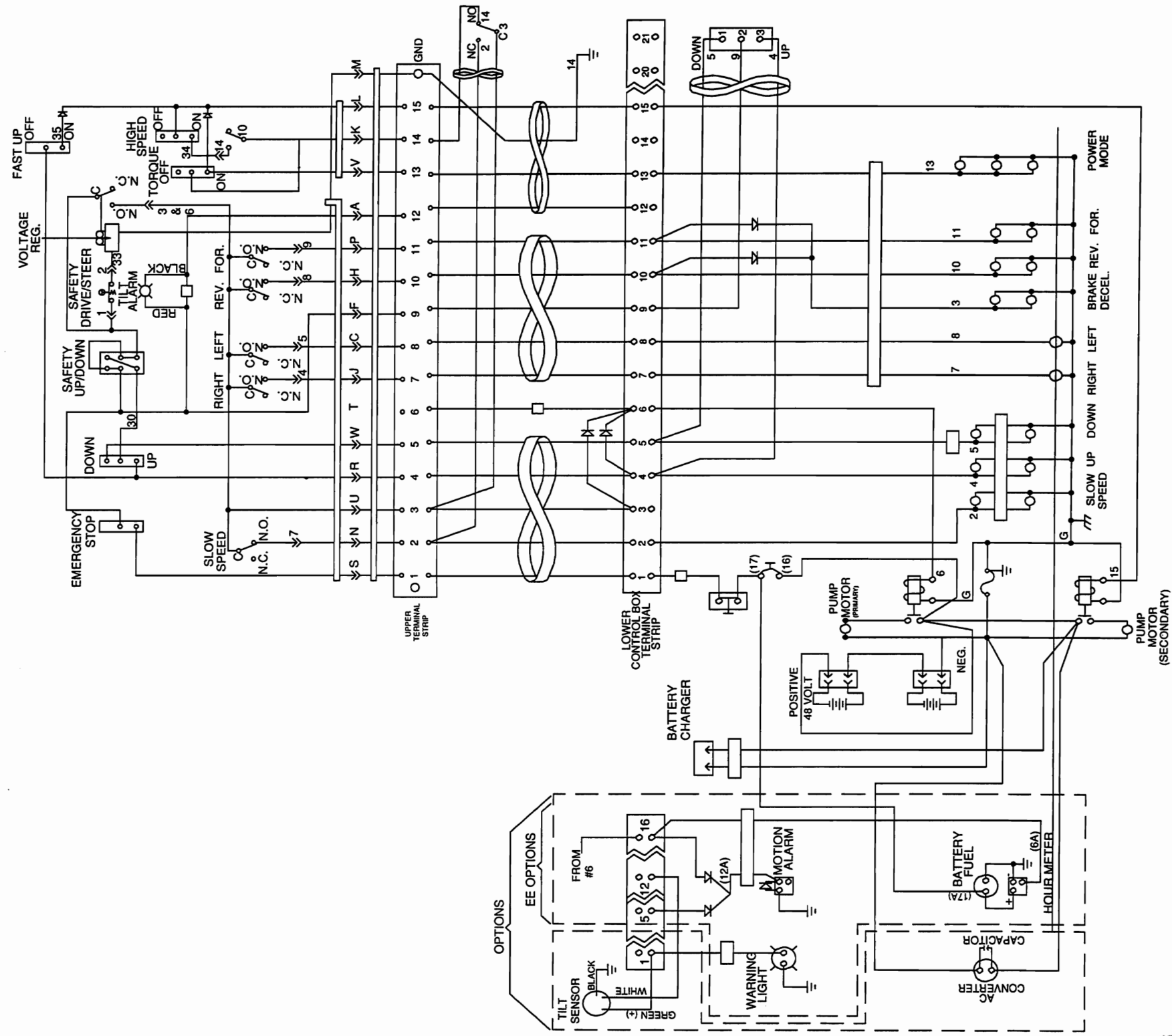

ART197

Figure 5-4. Quadrex 25SRT/33SRT Dual Fuel Electrical Harness Layout

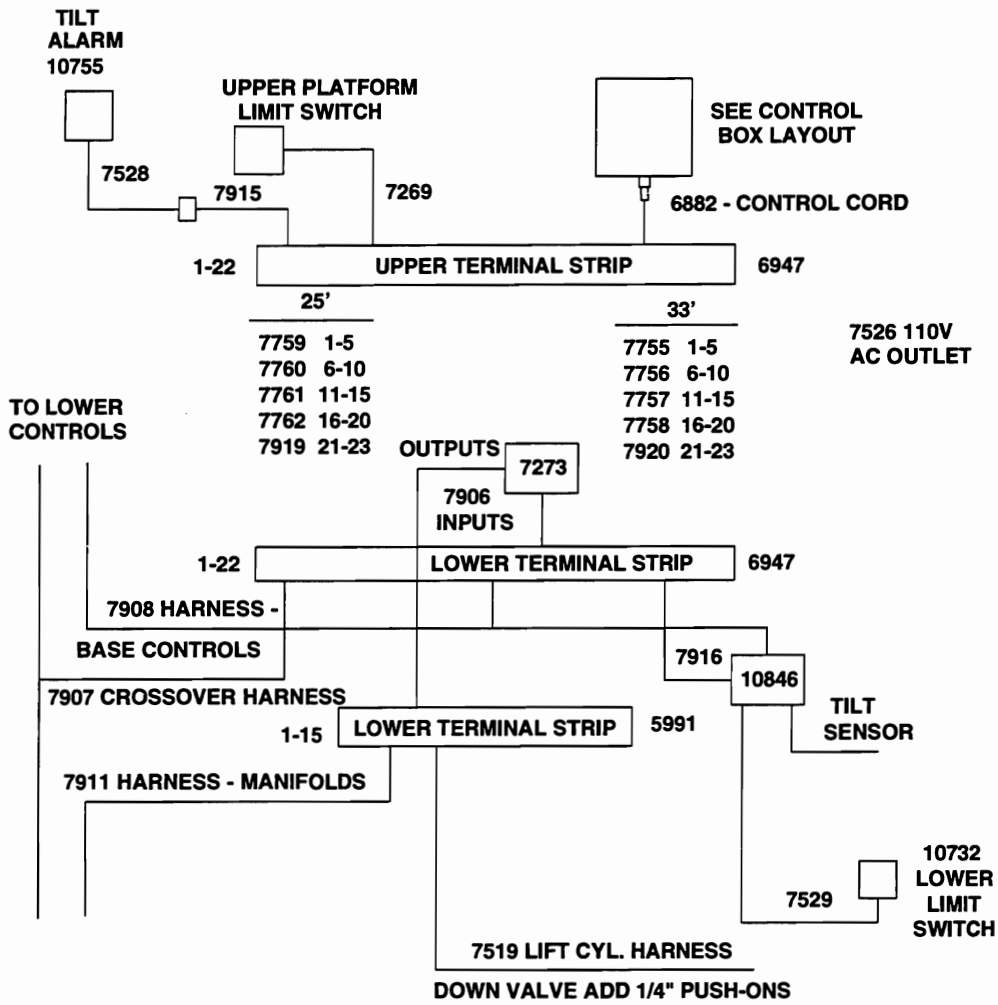

ART345

Figure 5-6. Quadrex 25E/33E Electrical Harness Layout

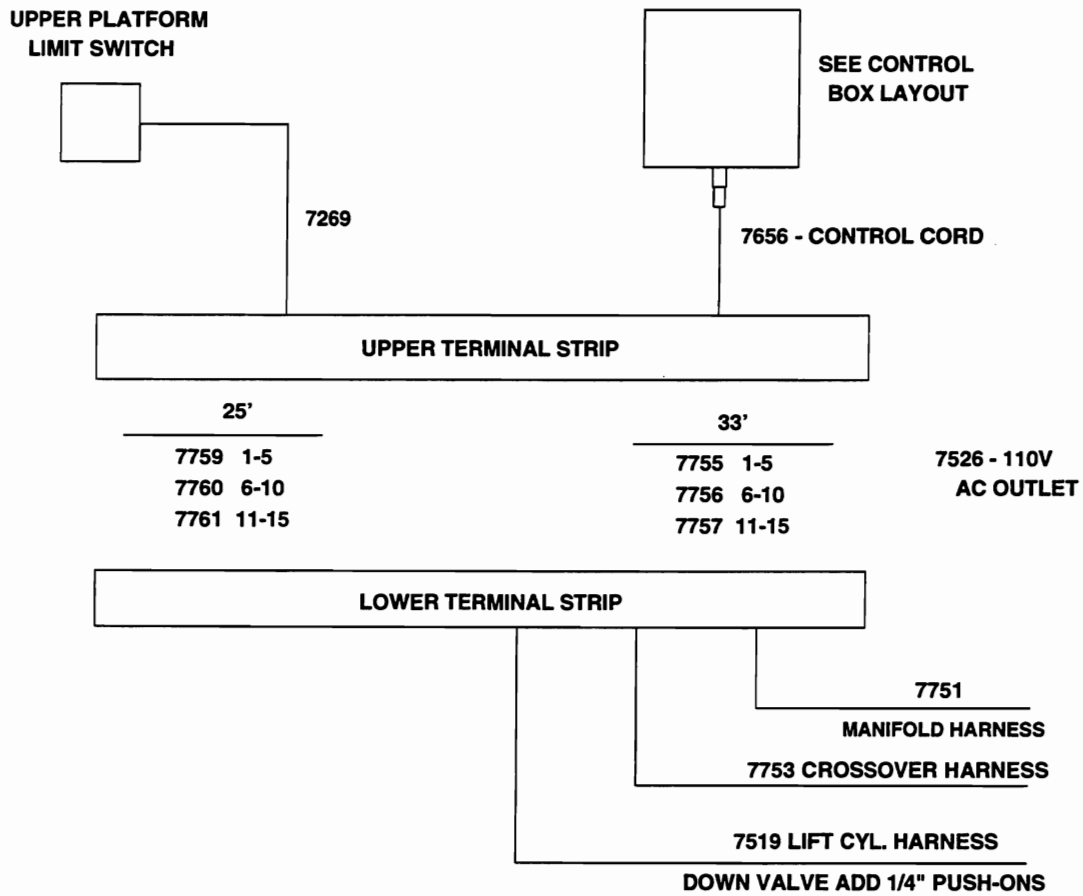

ART346

Figure 5-6. Quadrex 25E/33E Battery and Motor Cabling Layout

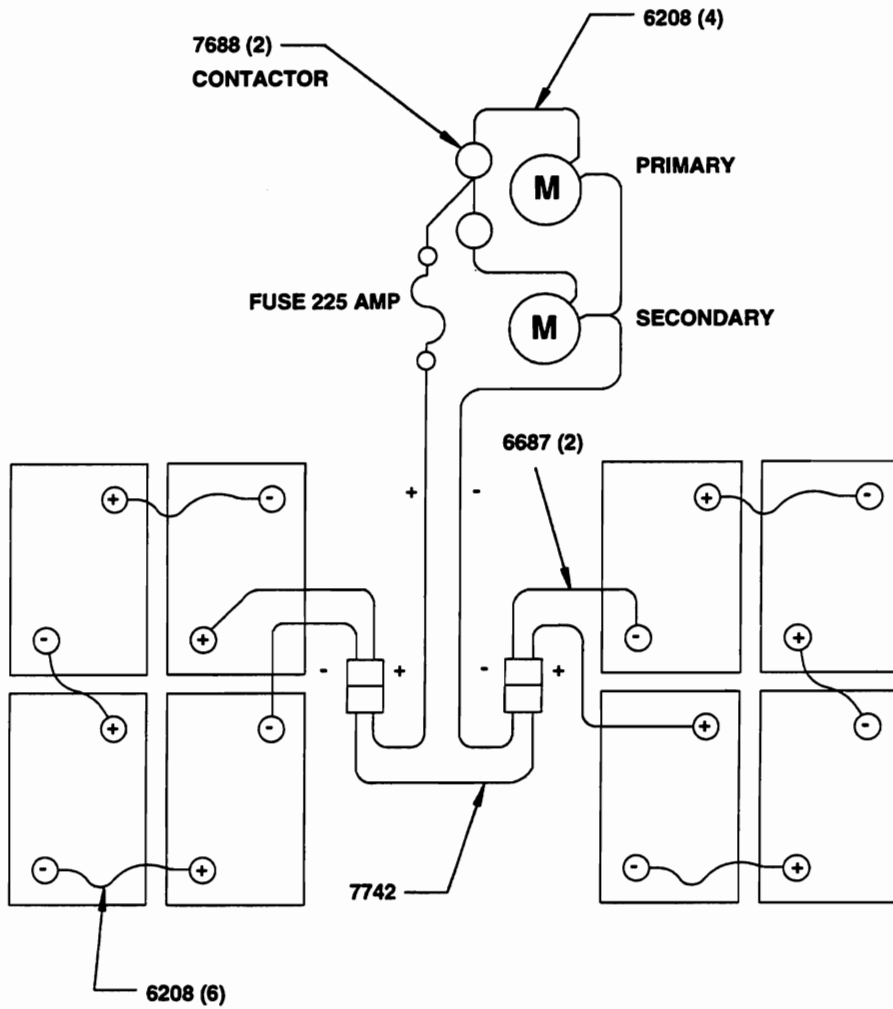

ART343

Figure 5-6. Quadrex Hydraulic Schematic

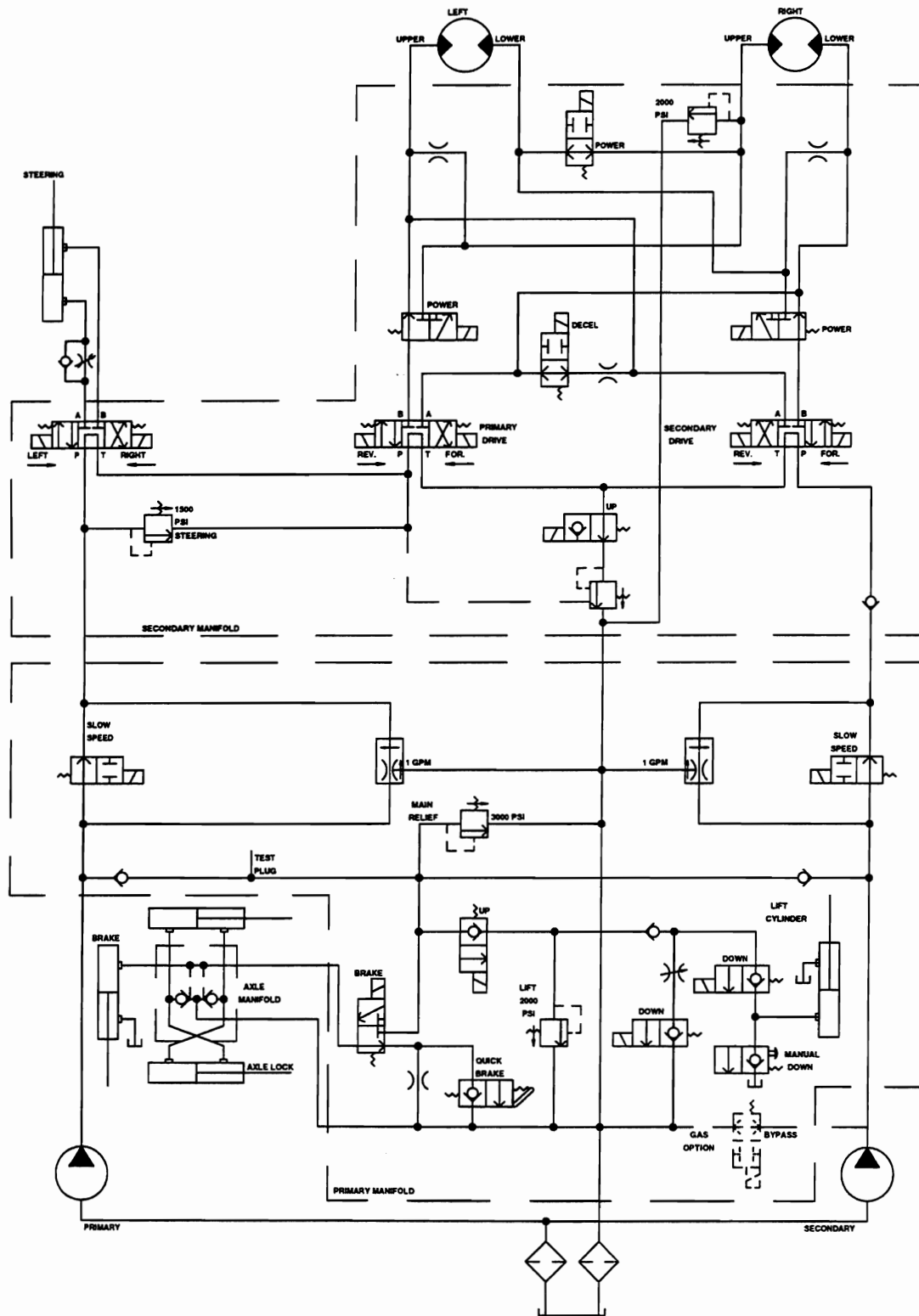

ART154
BM5104

Figure 7-1. Hydraulic Line Layout

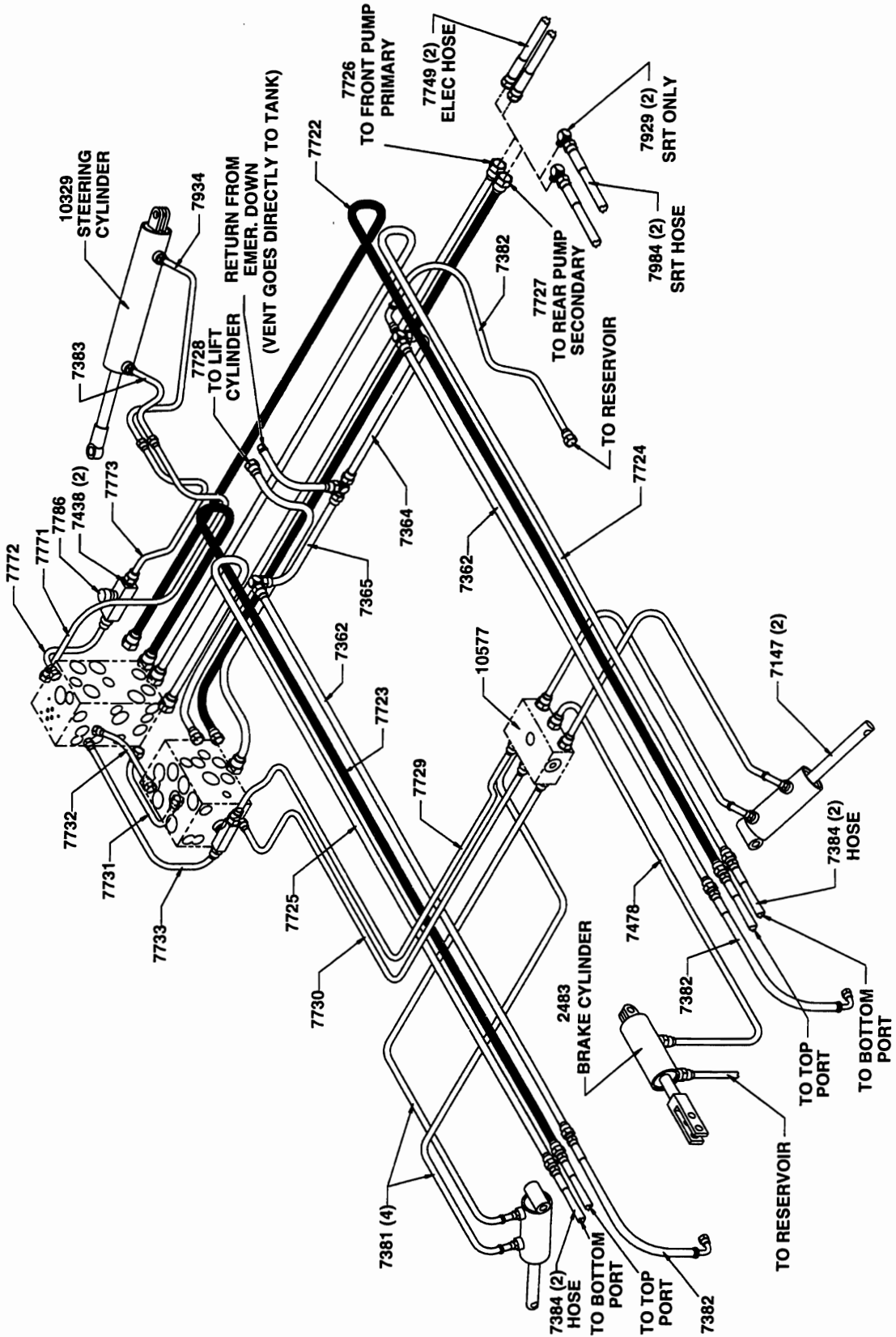

ART285

Figure 7-2. Primary Manifold

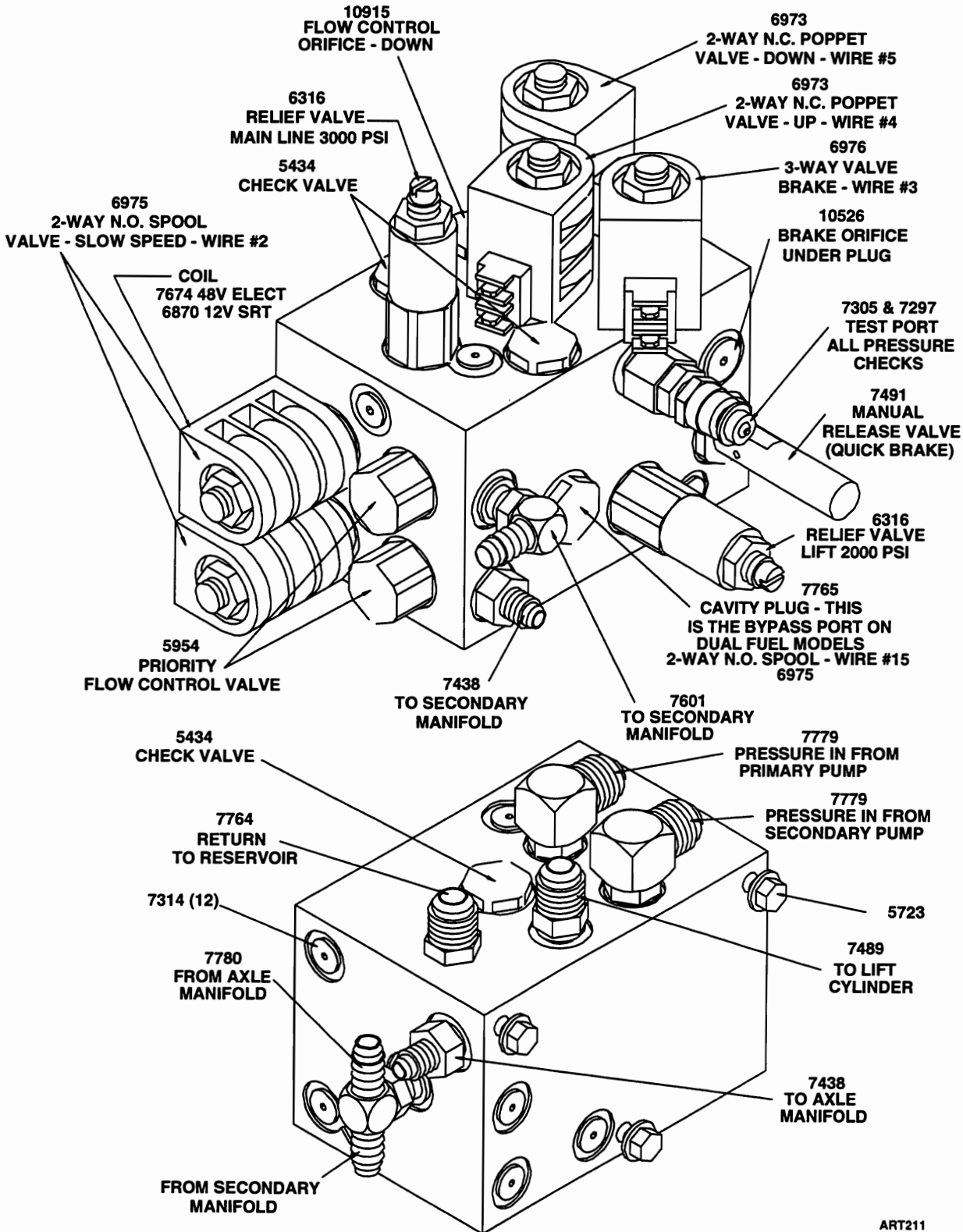

ART211

Figure 7-3. Secondary Manifold

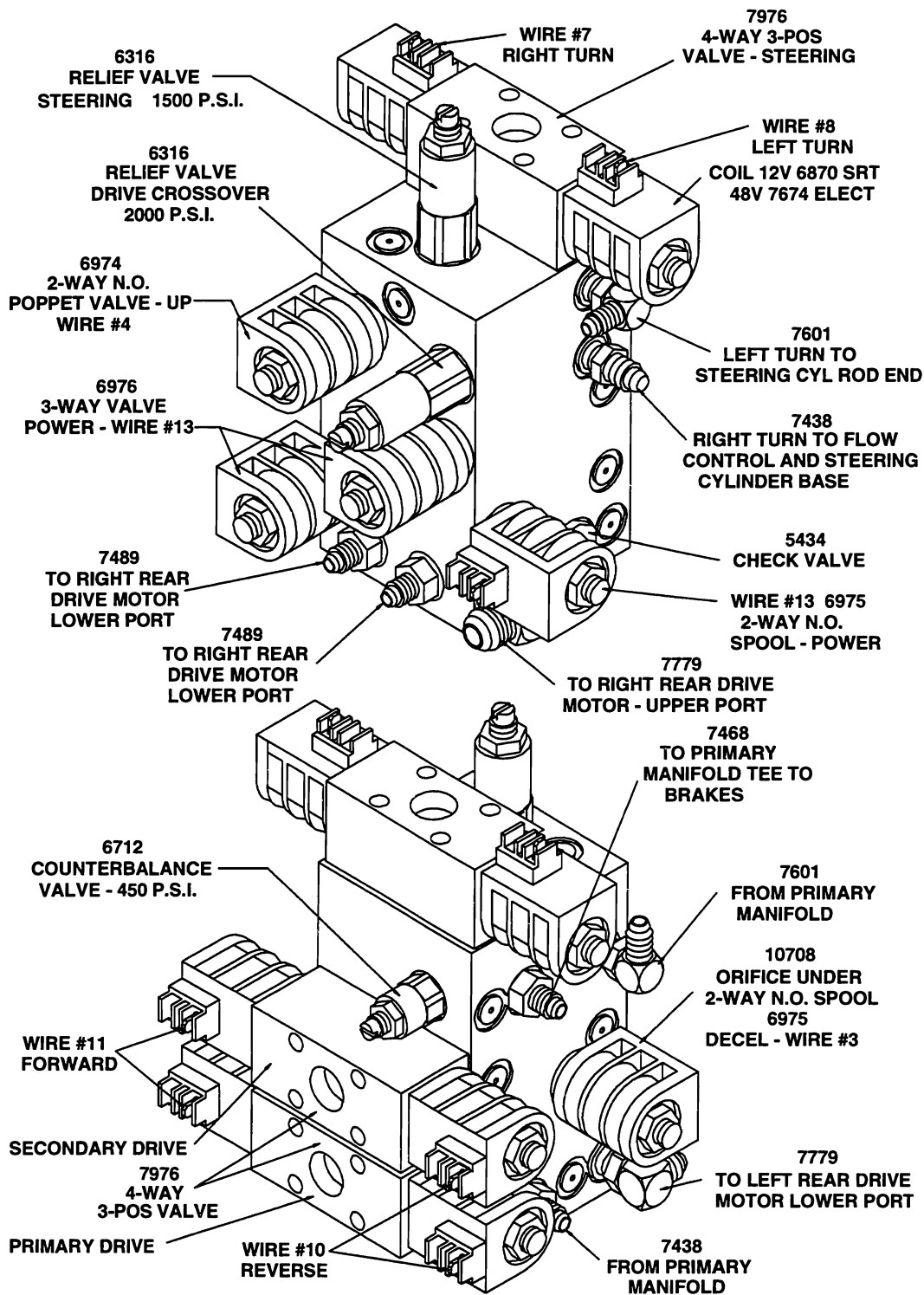

ART-212

Figure 7-4. Manifold Block

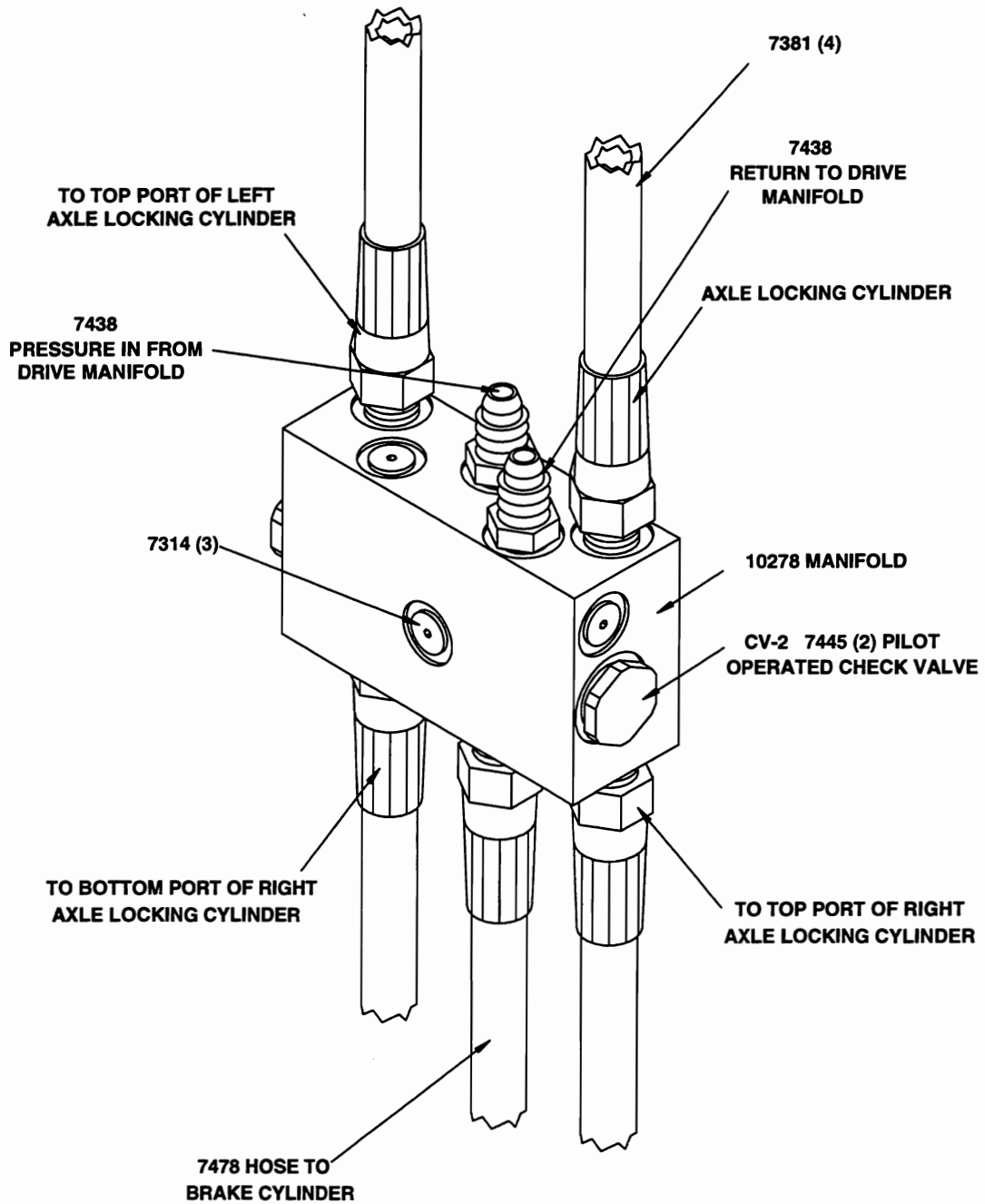

ART246